

## VRS 180 1-Stage Specifications

Frame Size	180									
Ratio	Unit	Note	3	4	5	6	7	8	9	10
Nominal Output Torque	[Nm]	*1	570	850	910	910	910	910	910	910
Maximum Acceleration Torque	[Nm]	*2	1300	1850	1850	1850	1850	1850	1350	1350
Maximum Torque	[Nm]	*3	1450	2250	2250	2150	2150	2150	1750	1750
Emergency Stop Torque	[Nm]	*4	2200	2750	2750	2750	2750	2750	2200	2200
Nominal Input Speed	[rpm]	*5	1500	1500	1500	1500	2300	2300	2300	2300
Maximum Input Speed	[rpm]	*6	4500	4500	4500	4500	4500	4500	4500	4500
No Load Running Torque	[Nm]	*7	2.68							
Maximum Radial Load	[N]	*8	19000							
Maximum Axial Load	[N]	*9	17000							
Moment of Inertia ( $\leq \varnothing 19$ )	[kgcm <sup>2</sup> ]	--	--	--	--	--	--	--	--	--
Moment of Inertia ( $\leq \varnothing 28$ )	[kgcm <sup>2</sup> ]	--	--	--	--	--	--	--	--	--
Moment of Inertia ( $\leq \varnothing 38$ )	[kgcm <sup>2</sup> ]	--	41	25	18	15	13	12	12	11
Moment of Inertia ( $\leq \varnothing 48$ )	[kgcm <sup>2</sup> ]	--	55	40	33	30	29	27	27	26
Moment of Inertia ( $\leq \varnothing 65$ )	[kgcm <sup>2</sup> ]	--	110	84	78	74	73	71	71	70
Efficiency	[%]	*10	95							
Torsional Rigidity	[Nm/arc-min]	*11	175							
Maximum Torsional Backlash	[arc-min]	--	Standard $\leq 3$ / Reduced $\leq 1$							
Noise Level	dB [A]	*12	$\leq 67$							
Protection Class	--	*13	IP54 (IP65)							
Ambient Temperature	[°C]	--	0-40							
Permitted Housing Temperature	[°C]	--	90							
Weight	[kg]	*14	39							

## VRS 180 2-Stage Specifications

Frame Size	180									
Ratio	Unit	Note	15	16	20	25	28	30	35	40
Nominal Output Torque	[Nm]	*1	660	850	910	1100	1300	930	1300	1200
Maximum Acceleration Torque	[Nm]	*2	1300	1850	1850	1850	1850	1300	1850	1850
Maximum Torque	[Nm]	*3	1300	1850	1850	1850	1850	1300	1850	1850
Emergency Stop Torque	[Nm]	*4	2200	2750	2750	2750	2750	2200	2750	2750
Nominal Input Speed	[rpm]	*5	2700	2700	2700	2700	2700	2700	2700	2700
Maximum Input Speed	[rpm]	*6	5000	5000	5000	5000	5000	5000	5000	5000
No Load Running Torque	[Nm]	*7	1.39							
Maximum Radial Load	[N]	*8	19000							
Maximum Axial Load	[N]	*9	17000							
Moment of Inertia ( $\leq \varnothing 19$ )	[kgcm <sup>2</sup> ]	--	--	--	--	--	--	--	--	--
Moment of Inertia ( $\leq \varnothing 28$ )	[kgcm <sup>2</sup> ]	--	8.7	11	8.1	7.8	11	4	7.6	3.9
Moment of Inertia ( $\leq \varnothing 38$ )	[kgcm <sup>2</sup> ]	--	15	18	14	14	17	10	14	10
Moment of Inertia ( $\leq \varnothing 48$ )	[kgcm <sup>2</sup> ]	--	30	32	29	29	32	25	29	25
Moment of Inertia ( $\leq \varnothing 65$ )	[kgcm <sup>2</sup> ]	--	34	39	33	33	38	26	32	26
Efficiency	[%]	*10	90							
Torsional Rigidity	[Nm/arc-min]	*11	175							
Maximum Torsional Backlash	[arc-min]	--	$\leq 3$							
Noise Level	dB [A]	*12	$\leq 67$							
Protection Class	--	*13	IP54 (IP65)							
Ambient Temperature	[°C]	--	0-40							
Permitted Housing Temperature	[°C]	--	90							
Weight	[kg]	*14	40							

## VRS 180 2-Stage Specifications

Frame Size	180										
Ratio	Unit	Note	45	50	60	70	80	90	100		
Nominal Output Torque	[Nm]	*1	930	1300	1300	1300	1300	930	930		
Maximum Acceleration Torque	[Nm]	*2	1350	1850	1850	1850	1850	1350	1350		
Maximum Torque	[Nm]	*3	1350	1850	1850	1850	1850	1350	1350		
Emergency Stop Torque	[Nm]	*4	2200	2750	2750	2750	2750	2200	2200		
Nominal Input Speed	[rpm]	*5	2700	2900	2900	3400	3400	3400	3400		
Maximum Input Speed	[rpm]	*6	5000	5000	5000	5000	5000	5000	5000		
No Load Running Torque	[Nm]	*7	1.39								
Maximum Radial Load	[N]	*8	19000								
Maximum Axial Load	[N]	*9	17000								
Moment of Inertia (≤ Ø 19)	[kgcm <sup>2</sup> ]	--	--	1.9	1.9	1.8	1.8	1.8	1.8		
Moment of Inertia (≤ Ø 28)	[kgcm <sup>2</sup> ]	--	7.6	3.8	3.8	3.8	3.7	3.7	3.7		
Moment of Inertia (≤ Ø 38)	[kgcm <sup>2</sup> ]	--	14	10	10	10	10	10	10		
Moment of Inertia (≤ Ø 48)	[kgcm <sup>2</sup> ]	--	29	25	25	25	25	25	25		
Moment of Inertia (≤ Ø 65)	[kgcm <sup>2</sup> ]	--	32	26	26	26	26	26	26		
Efficiency	[%]	*10	90								
Torsional Rigidity	[Nm/arc-min]	*11	175								
Maximum Torsional Backlash	[arc-min]	--	≤ 3								
Noise Level	dB [A]	*12	≤ 67								
Protection Class	--	*13	IP54 (IP65)								
Ambient Temperature	[°C]	--	0-40								
Permitted Housing Temperature	[°C]	--	90								
Weight	[kg]	*14	40								

\*1 At nominal input speed, service life is 20,000 hours

\*2 The maximum torque when starting or stopping operation. Apply Cycle Factor  $f_0$ , found on page 468, for higher duty cycle applications

\*3 Permitted 10,000 times during service life. Based on 10% of maximum radial load and smooth output shaft

\*4 The maximum torque allowed under a stress situation. Permitted 1,000 times during service life

\*5 The average input speed at nominal input torque. Maintain housing temperature below permitted value

\*6 The maximum intermittent input speed

\*7 Torque at no load applied to the input shaft at nominal input speed

\*8 The maximum radial load that the gearbox can accept

\*9 The maximum axial load that the gearbox can accept

\*10 The efficiency at the nominal output torque rating

\*11 This does not include lost motion

\*12 Contact Nidec Drive Technology for the testing conditions and environment

\*13 IP65 (wash-down) is available as an option. Contact Nidec Drive Technology for more details

\*14 Weight may vary slightly between models

VRSF

PRE

PRF

VRL

VRB

VRS

VRT

# PLANETARY Inline Gear Reducers

## VRS 180 1-Stage Dimensions

Input bore size  $\leq \varnothing 38$  mm

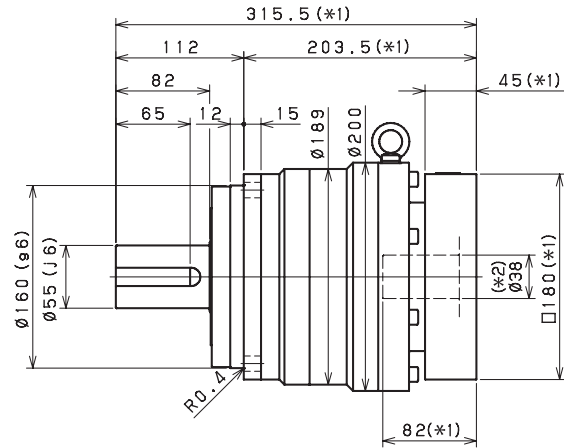
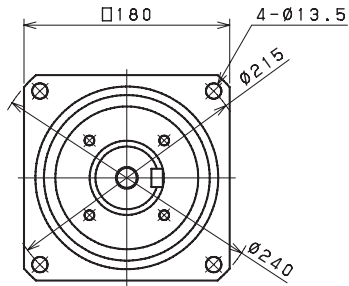

Input bore size  $\leq \varnothing 48$  mm

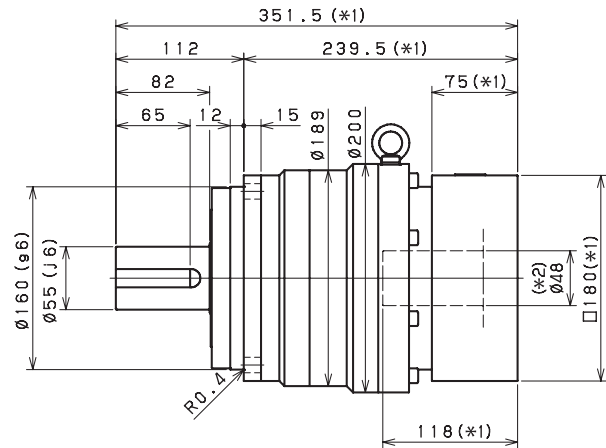
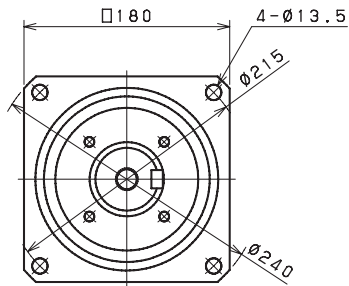

Input bore size  $\leq \varnothing 65$  mm

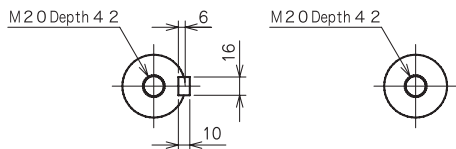
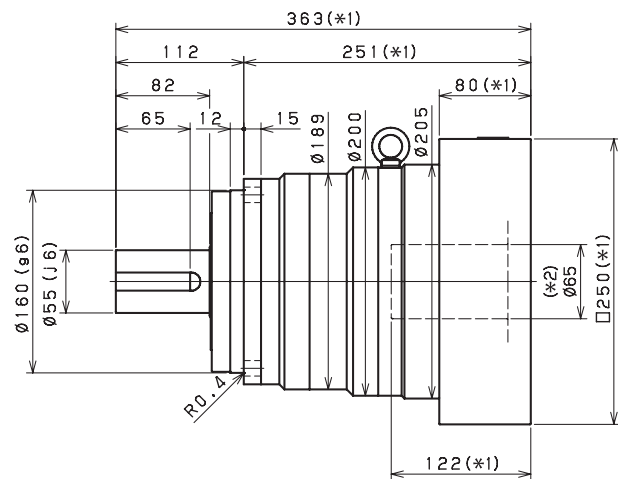
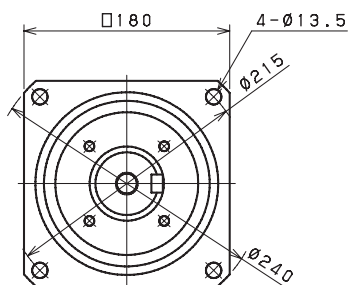

Keyed shaft

Smooth shaft

\*1 Length will vary depending on motor

\*2 Bushing will be inserted to adapt to motor shaft

## VRS 180 2-Stage Dimensions

Input bore size  $\leq \phi 28$  mm

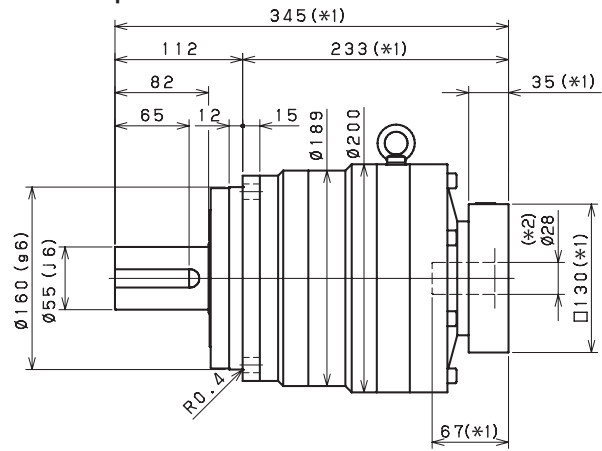
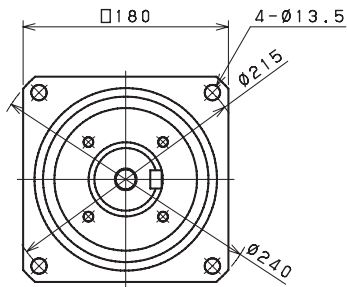

Input bore size  $\leq \phi 38$  mm

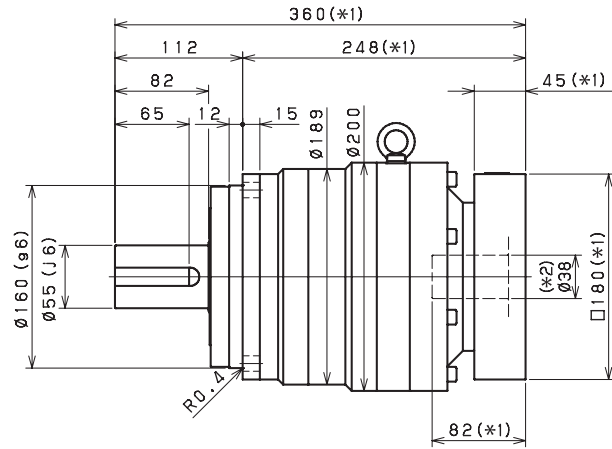
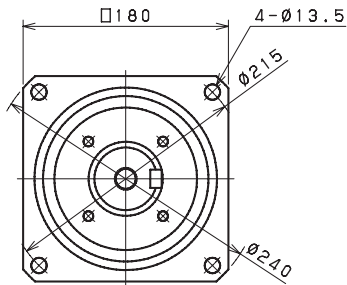

Input bore size  $\leq \phi 48$  mm

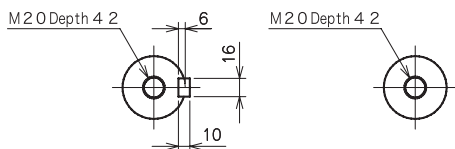
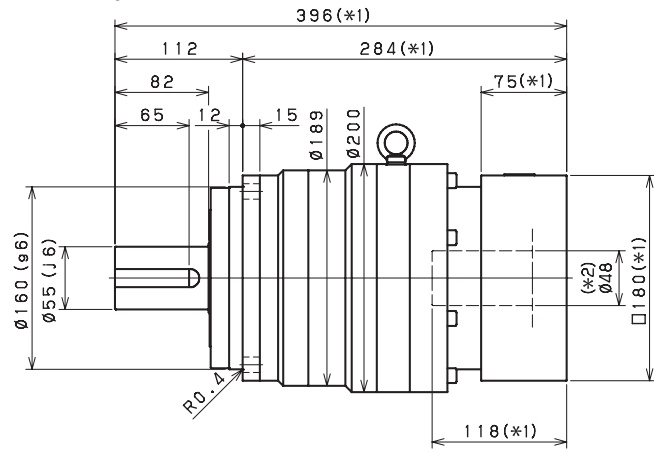
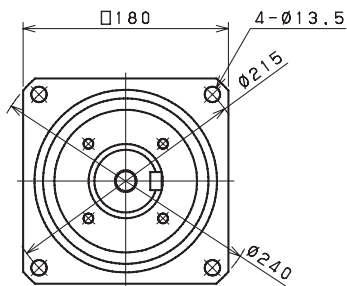

Keyed shaft

Smooth shaft

- \*1 Length will vary depending on motor
- \*2 Bushing will be inserted to adapt to motor shaft

VRSF

PRE

PRF

URL

VRB

VRS

VRT