

VRS 140 1-Stage Specifications

Frame Size	140									
Ratio	Unit	Note	3	4	5	6	7	8	9	10
Nominal Output Torque	[Nm]	*1	248	280	380	380	380	380	380	380
Maximum Acceleration Torque	[Nm]	*2	560	840	840	840	840	840	610	610
Maximum Torque	[Nm]	*3	630	1000	1000	950	950	950	730	730
Emergency Stop Torque	[Nm]	*4	1000	1250	1250	1250	1250	1250	1000	1000
Nominal Input Speed	[rpm]	*5	2100	2100	2100	2100	2600	2600	2600	2600
Maximum Input Speed	[rpm]	*6	5000	5000	5000	5000	5000	5000	5000	5000
No Load Running Torque	[Nm]	*7	1.63							
Maximum Radial Load	[N]	*8	10000							
Maximum Axial Load	[N]	*9	9000							
Moment of Inertia ($\leq \varnothing 14$)	[kgcm ²]	--	--	--	--	--	--	--	--	--
Moment of Inertia ($\leq \varnothing 19$)	[kgcm ²]	--	--	--	--	--	--	--	--	--
Moment of Inertia ($\leq \varnothing 28$)	[kgcm ²]	--	12	7.2	5.2	4.3	3.8	3.5	3.3	3.2
Moment of Inertia ($\leq \varnothing 38$)	[kgcm ²]	--	18	14	12	11	10	9.9	9.7	9.6
Moment of Inertia ($\leq \varnothing 48$)	[kgcm ²]	--	35	29	27	26	25	25	25	25
Efficiency	[%]	*10	95							
Torsional Rigidity	[Nm/arc-min]	*11	60							
Maximum Torsional Backlash	[arc-min]	--	Standard ≤ 3 / Reduced ≤ 1							
Noise Level	dB [A]	*12	≤ 67							
Protection Class	--	*13	IP54 (IP65)							
Ambient Temperature	[°C]	--	0-40							
Permitted Housing Temperature	[°C]	--	90							
Weight	[kg]	*14	17							

VRS 140 2-Stage Specifications

Frame Size	140									
Ratio	Unit	Note	15	16	20	25	28	30	35	40
Nominal Output Torque	[Nm]	*1	360	380	410	590	590	440	590	500
Maximum Acceleration Torque	[Nm]	*2	560	840	840	840	840	560	840	840
Maximum Torque	[Nm]	*3	560	840	840	840	840	560	840	840
Emergency Stop Torque	[Nm]	*4	1000	1250	1250	1250	1250	1000	1250	1250
Nominal Input Speed	[rpm]	*5	2900	2900	2900	2900	2900	2900	2900	2900
Maximum Input Speed	[rpm]	*6	6000	6000	6000	6000	6000	6000	6000	6000
No Load Running Torque	[Nm]	*7	0.56							
Maximum Radial Load	[N]	*8	10000							
Maximum Axial Load	[N]	*9	9000							
Moment of Inertia ($\leq \varnothing 14$)	[kgcm ²]	--	--	--	--	--	--	--	--	--
Moment of Inertia ($\leq \varnothing 19$)	[kgcm ²]	--	2.6	3.5	2.4	2.4	3.3	1.1	2.3	1.1
Moment of Inertia ($\leq \varnothing 28$)	[kgcm ²]	--	4.4	5.3	4.2	4.1	5.1	2.9	4.1	2.8
Moment of Inertia ($\leq \varnothing 38$)	[kgcm ²]	--	11	12	10	10	11	9.2	10	9.1
Moment of Inertia ($\leq \varnothing 48$)	[kgcm ²]	--	26	27	25	25	26	24	25	24
Efficiency	[%]	*10	90							
Torsional Rigidity	[Nm/arc-min]	*11	60							
Maximum Torsional Backlash	[arc-min]	--	≤ 3							
Noise Level	dB [A]	*12	≤ 67							
Protection Class	--	*13	IP54 (IP65)							
Ambient Temperature	[°C]	--	0-40							
Permitted Housing Temperature	[°C]	--	90							
Weight	[kg]	*14	19							

VRS 140 2-Stage Specifications

Frame Size	140										
Ratio	Unit	Note	45	50	60	70	80	90	100		
Nominal Output Torque	[Nm]	*1	440	590	590	590	590	440	440		
Maximum Acceleration Torque	[Nm]	*2	610	840	840	840	840	610	610		
Maximum Torque	[Nm]	*3	610	840	840	840	840	610	610		
Emergency Stop Torque	[Nm]	*4	1000	1250	1250	1250	1250	1000	1000		
Nominal Input Speed	[rpm]	*5	2900	3200	3200	3900	3900	3900	3900		
Maximum Input Speed	[rpm]	*6	6000	6000	6000	6000	6000	6000	6000		
No Load Running Torque	[Nm]	*7	0.56								
Maximum Radial Load	[N]	*8	10000								
Maximum Axial Load	[N]	*9	9000								
Moment of Inertia ($\leq \varnothing 14$)	[kgcm ²]	--	--	0.65	0.64	0.64	0.63	0.63	0.63		
Moment of Inertia ($\leq \varnothing 19$)	[kgcm ²]	--	2.3	1.1	1.1	1.1	1.1	1.1	1.1		
Moment of Inertia ($\leq \varnothing 28$)	[kgcm ²]	--	4.0	2.8	2.8	2.8	2.8	2.8	2.8		
Moment of Inertia ($\leq \varnothing 38$)	[kgcm ²]	--	10	9.1	9.1	9.1	9.1	9.1	9.1		
Moment of Inertia ($\leq \varnothing 48$)	[kgcm ²]	--	25	24	24	24	24	24	24		
Efficiency	[%]	*10	90								
Torsional Rigidity	[Nm/arc-min]	*11	60								
Maximum Torsional Backlash	[arc-min]	--	≤ 3								
Noise Level	dB [A]	*12	≤ 67								
Protection Class	--	*13	IP54 (IP65)								
Ambient Temperature	[°C]	--	0-40								
Permitted Housing Temperature	[°C]	--	90								
Weight	[kg]	*14	19								

*1 At nominal input speed, service life is 20,000 hours

*2 The maximum torque when starting or stopping operation. Apply Cycle Factor f_0 , found on page 468, for higher duty cycle applications

*3 Permitted 10,000 times during service life. Based on 10% of maximum radial load and smooth output shaft

*4 The maximum torque allowed under a stress situation. Permitted 1,000 times during service life

*5 The average input speed at nominal input torque. Maintain housing temperature below permitted value

*6 The maximum intermittent input speed

*7 Torque at no load applied to the input shaft at nominal input speed

*8 The maximum radial load that the gearbox can accept

*9 The maximum axial load that the gearbox can accept

*10 The efficiency at the nominal output torque rating

*11 This does not include lost motion

*12 Contact Nidec Drive Technology for the testing conditions and environment

*13 IP65 (wash-down) is available as an option. Contact Nidec Drive Technology for more details

*14 Weight may vary slightly between models

VRSF

PRE

PRF

VRL

VRS

VRS

VRT

PLANETARY Inline Gear Reducers

VRS 140 1-Stage Dimensions

Input bore size $\leq \varnothing 28$ mm

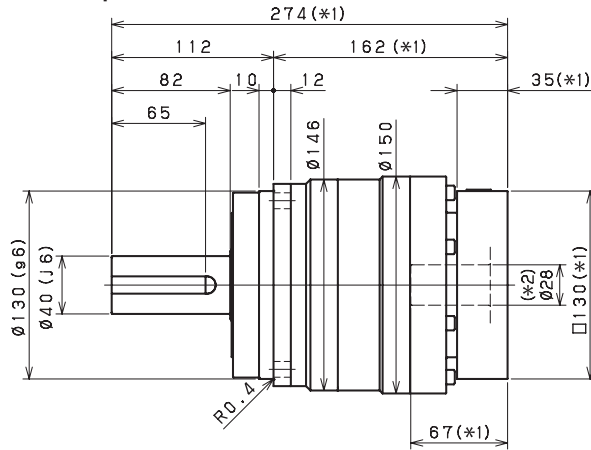
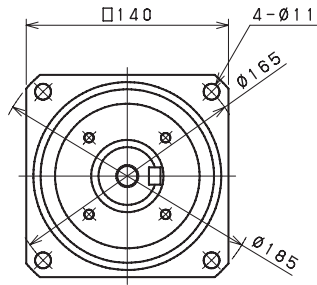

Input bore size $\leq \varnothing 38$ mm

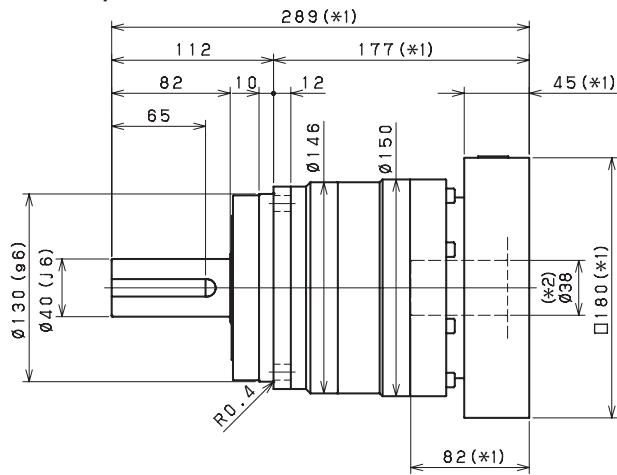
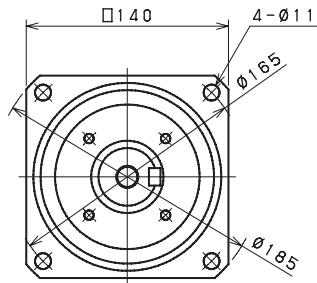

Input bore size $\leq \varnothing 48$ mm

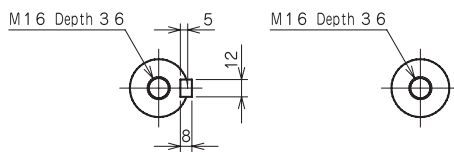
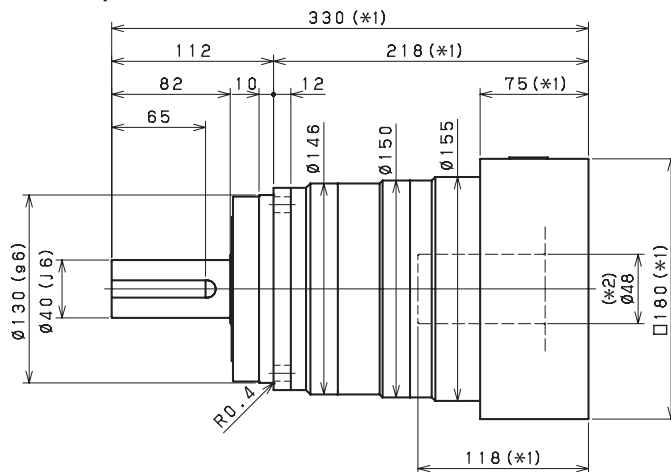
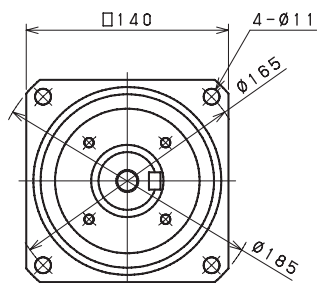

Keyed shaft

Smooth shaft

*1 Length will vary depending on motor

*2 Bushing will be inserted to adapt to motor shaft

VRS 140 2-Stage Dimensions

Input bore size $\leq \phi 19$ mm

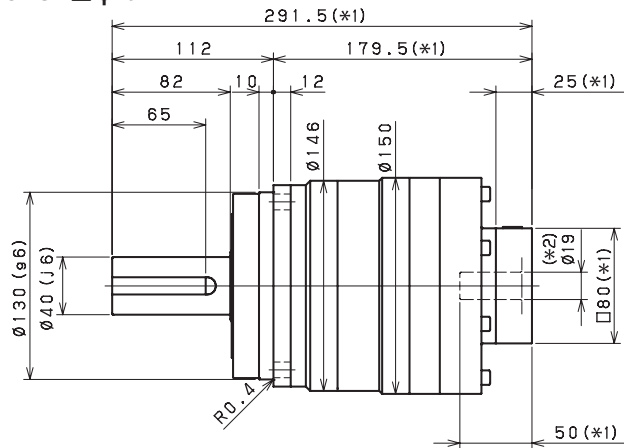
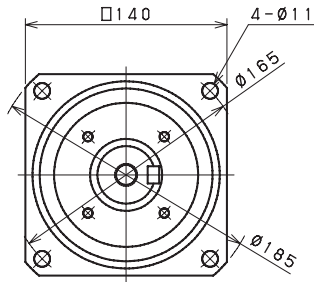

Input bore size $\leq \phi 28$ mm

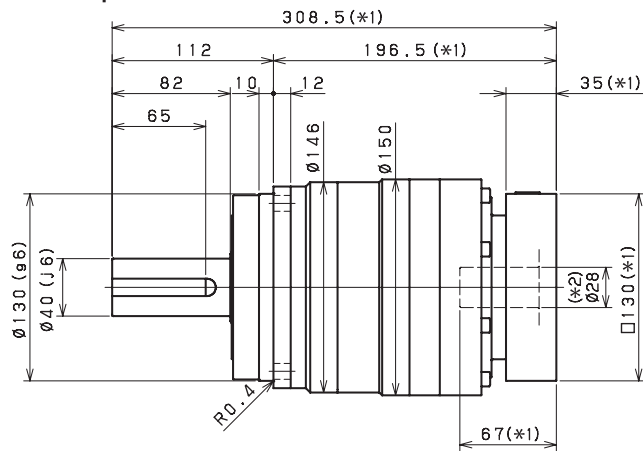
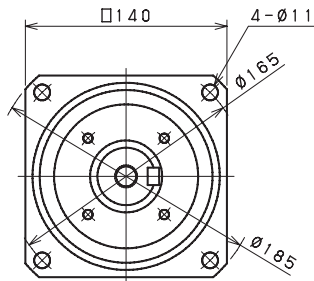

Input bore size $\leq \phi 38$ mm ^(*3)

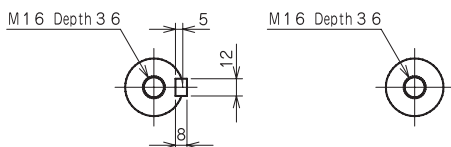
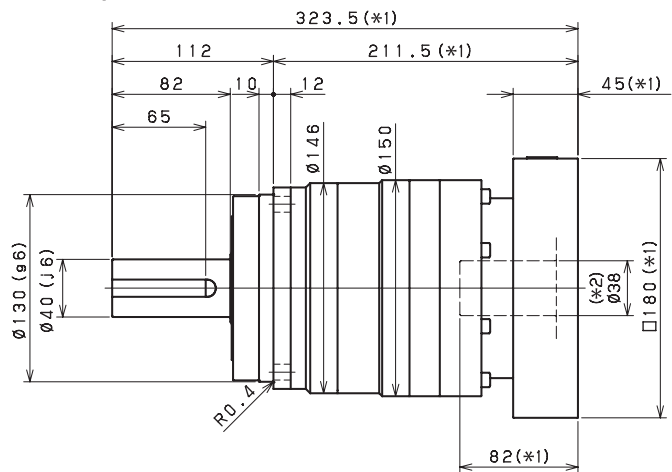
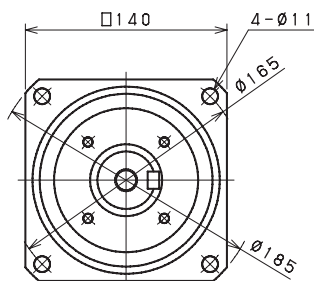

Keyed shaft

Smooth shaft

*1 Length will vary depending on motor

*2 Bushing will be inserted to adapt to motor shaft

*3 48mm input bore is available for this frame size. Use our online configurator to make your selection or contact us for assistance

VRSF

PRE

PRF

VRL

VRB

VRS

VRT