

VRL 235 1-Stage Specifications

Frame Size	235									
Ratio	Unit	Note	3	4	5	6	7	8	9	10
Nominal Output Torque	[Nm]	*1	980	1400	1400	1600	1700	1700	1700	1700
Maximum Acceleration Torque	[Nm]	*2	2000	2900	2900	2900	2900	2900	2600	2200
Maximum Torque	[Nm]	*3	2400	3700	3700	3500	3500	3400	3000	2700
Emergency Stop Torque	[Nm]	*4	4000	5000	5000	5000	5000	5000	4000	4000
Nominal Input Speed	[rpm]	*5	1200	1200	1500	1500	1700	1700	2000	2000
Maximum Input Speed	[rpm]	*6	3000	3000	3000	3000	3000	3000	3000	3000
No Load Running Torque	[Nm]	*7	2.92							
Maximum Radial Load	[N]	*8	15000							
Maximum Axial Load	[N]	*9	14000							
Moment of Inertia ($\leq \varnothing 28$)	[kgcm ²]	--	--	--	--	--	--	--	--	--
Moment of Inertia ($\leq \varnothing 38$)	[kgcm ²]	--	--	--	--	--	--	--	--	--
Moment of Inertia ($\leq \varnothing 48$)	[kgcm ²]	--	110	54	42	35	33	30	29	28
Moment of Inertia ($\leq \varnothing 65$)	[kgcm ²]	--	160	98	85	79	76	74	73	72
Efficiency	[%]	*10	95							
Torsional Rigidity	[Nm/arc-min]	*11	400							
Maximum Torsional Backlash	[arc-min]	--	≤ 5							
Noise Level	dB [A]	*12	≤ 61							
Protection Class	--	*13	IP54 (IP65)							
Ambient Temperature	[°C]	--	0-40							
Permitted Housing Temperature	[°C]	--	90							
Weight	[kg]	*14	55							

VRL 235 2-Stage Specifications

Frame Size	235									
Ratio	Unit	Note	15	16	20	25	28	30	35	40
Nominal Output Torque	[Nm]	*1	1100	1400	1500	1800	2000	1300	2000	2000
Maximum Acceleration Torque	[Nm]	*2	2000	2900	2900	2900	2900	2000	2900	2900
Maximum Torque	[Nm]	*3	2000	2900	2900	2900	2900	2000	2900	2900
Emergency Stop Torque	[Nm]	*4	4000	5000	5000	5000	5000	4000	5000	5000
Nominal Input Speed	[rpm]	*5	2200	2200	2200	2200	2200	2200	2200	2200
Maximum Input Speed	[rpm]	*6	4500	4500	4500	4500	4500	4500	4500	4500
No Load Running Torque	[Nm]	*7	1.14							
Maximum Radial Load	[N]	*8	15000							
Maximum Axial Load	[N]	*9	14000							
Moment of Inertia ($\leq \varnothing 28$)	[kgcm ²]	--	--	--	--	--	--	--	--	--
Moment of Inertia ($\leq \varnothing 38$)	[kgcm ²]	--	20	24	19	18	23	12	18	12
Moment of Inertia ($\leq \varnothing 48$)	[kgcm ²]	--	34	39	33	33	37	26	32	26
Moment of Inertia ($\leq \varnothing 65$)	[kgcm ²]	--	--	--	--	--	--	--	--	--
Efficiency	[%]	*10	90							
Torsional Rigidity	[Nm/arc-min]	*11	400							
Maximum Torsional Backlash	[arc-min]	--	≤ 5							
Noise Level	dB [A]	*12	≤ 61							
Protection Class	--	*13	IP54 (IP65)							
Ambient Temperature	[°C]	--	0-40							
Permitted Housing Temperature	[°C]	--	90							
Weight	[kg]	*14	57							

VRL 235 2-Stage Specifications

Frame Size	235										
Ratio	Unit	Note	45	50	60	70	80	90	100		
Nominal Output Torque	[Nm]	*1	1300	2000	2000	2000	2000	1300	1300		
Maximum Acceleration Torque	[Nm]	*2	1800	2900	2900	2900	2500	1800	1600		
Maximum Torque	[Nm]	*3	1800	2900	2900	2900	2500	1800	1600		
Emergency Stop Torque	[Nm]	*4	4000	5000	5000	5000	5000	4000	4000		
Nominal Input Speed	[rpm]	*5	2200	2500	2500	3000	3000	3000	3000		
Maximum Input Speed	[rpm]	*6	4500	4500	4500	4500	4500	4500	4500		
No Load Running Torque	[Nm]	*7	1.14								
Maximum Radial Load	[N]	*8	15000								
Maximum Axial Load	[N]	*9	14000								
Moment of Inertia ($\leq \varnothing 28$)	[kgcm ²]	--	--	4.7	4.7	4.6	4.6	4.6	4.6		
Moment of Inertia ($\leq \varnothing 38$)	[kgcm ²]	--	18	12	11	11	11	11	11		
Moment of Inertia ($\leq \varnothing 48$)	[kgcm ²]	--	32	26	26	26	26	26	26		
Moment of Inertia ($\leq \varnothing 65$)	[kgcm ²]	--	--	--	--	--	--	--	--		
Efficiency	[%]	*10	90								
Torsional Rigidity	[Nm/arc-min]	*11	400								
Maximum Torsional Backlash	[arc-min]	--	≤ 5								
Noise Level	dB [A]	*12	≤ 61								
Protection Class	--	*13	IP54 (IP65)								
Ambient Temperature	[°C]	--	0-40								
Permitted Housing Temperature	[°C]	--	90								
Weight	[kg]	*14	57								

- *1 At nominal input speed, service life is 20,000 hours
- *2 The maximum torque when starting or stopping operation. Apply Cycle Factor f_0 , found on page 468, for higher duty cycle applications
- *3 Permitted 10,000 times during service life. Based on 10% of maximum radial load and smooth output shaft
- *4 The maximum torque allowed under a stress situation. Permitted 1,000 times during service life
- *5 The average input speed at nominal input torque. Maintain housing temperature below permitted value
- *6 The maximum intermittent input speed
- *7 Torque at no load applied to the input shaft at nominal input speed
- *8 The maximum radial load that the gearbox can accept
- *9 The maximum axial load that the gearbox can accept
- *10 The efficiency at the nominal output torque rating
- *11 This does not include lost motion
- *12 Contact Nidec Drive Technology for the testing conditions and environment
- *13 IP65 (wash-down) is available as an option. Contact Nidec Drive Technology for more details
- *14 Weight may vary slightly between models

VRSF

PRE

PRF

VRL

VRB

VRS

VRT

PLANETARY Inline Gear Reducers

VRL 235 1-Stage Dimensions

Input bore size $\cong \varnothing 48$ mm

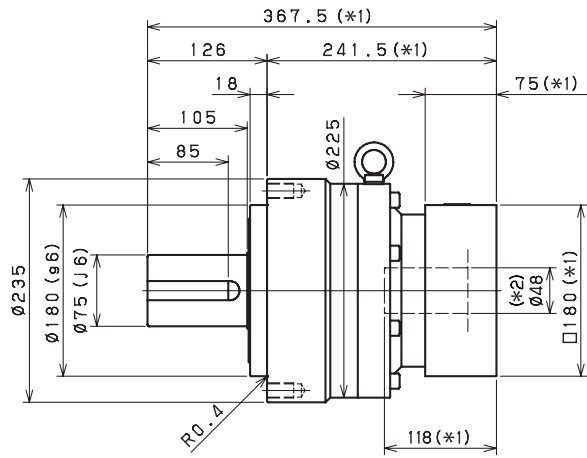
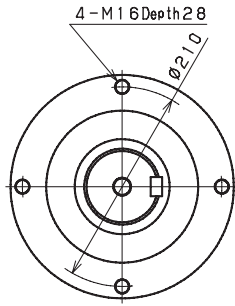

Input bore size $\cong \varnothing 65$ mm

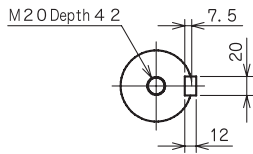
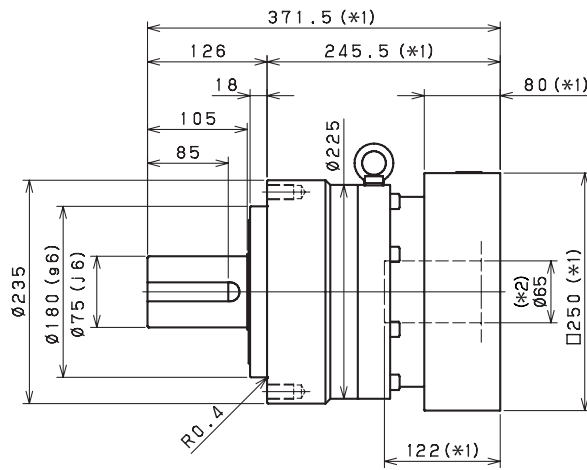
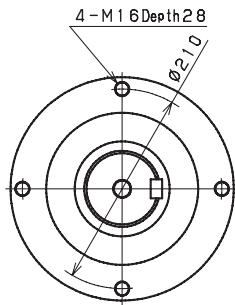

Keyed shaft

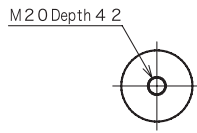

Smooth shaft

*1 Length will vary depending on motor

*2 Bushing will be inserted to adapt to motor shaft

VRL 235 2-Stage Dimensions

Input bore size $\leq \phi 38$ mm

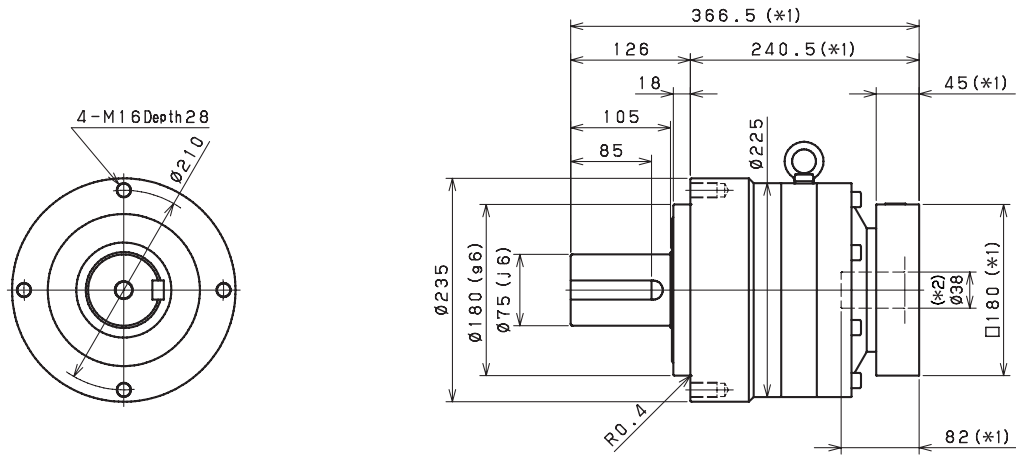

Input bore size $\leq \phi 48$ mm

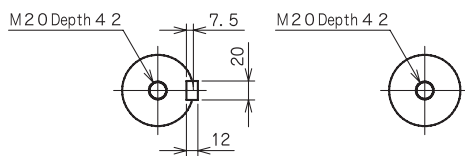
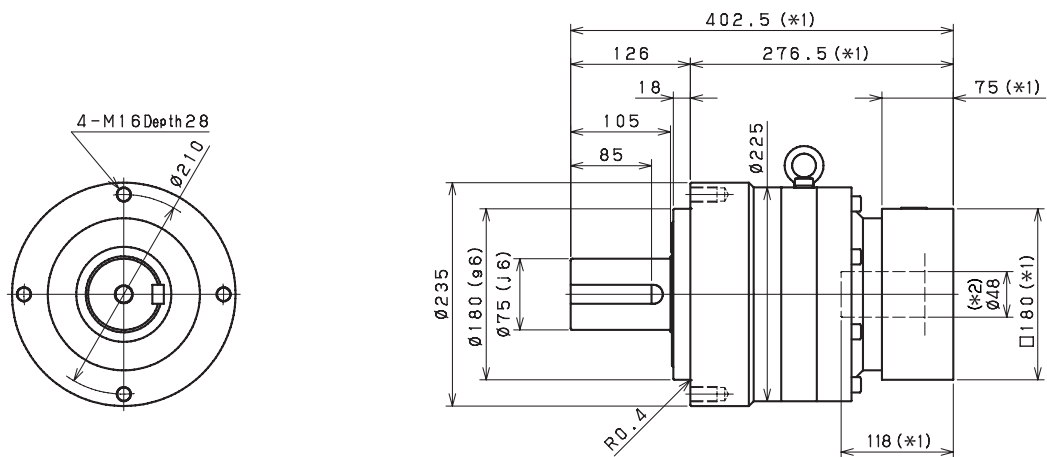

- *1 Length will vary depending on motor
- *2 Bushing will be inserted to adapt to motor shaft

VRSF

PRE

PRF

VRL

VRB

VRS

VRT