

VRB SERIES

A valuable alternative for applications requiring high positional accuracy and dynamic performance. The VRB is a <3 arc-min gear reducer that offers a through hole mounting design, making it easier to assemble onto various equipment. This product is an ideal fit for various belt drive and actuator applications found throughout the packaging and assembly cell automation markets.

Various standard wash down and food grade options are available, making the VRB an attractive choice for the toughest environments. We offer the broadest selection of frame sizes and ratios, with immediate availability on most configurations. Industry standard mounting dimensions allow the VRB to be employed in legacy equipment designs, saving our customers time and money.

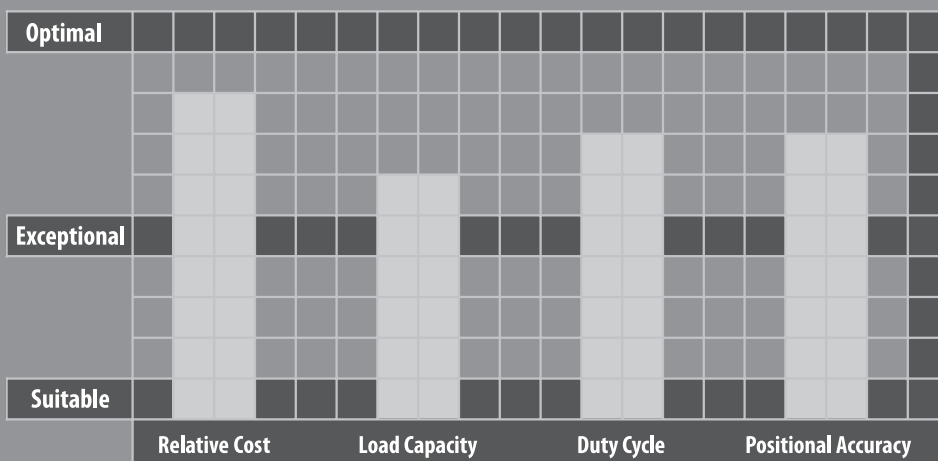

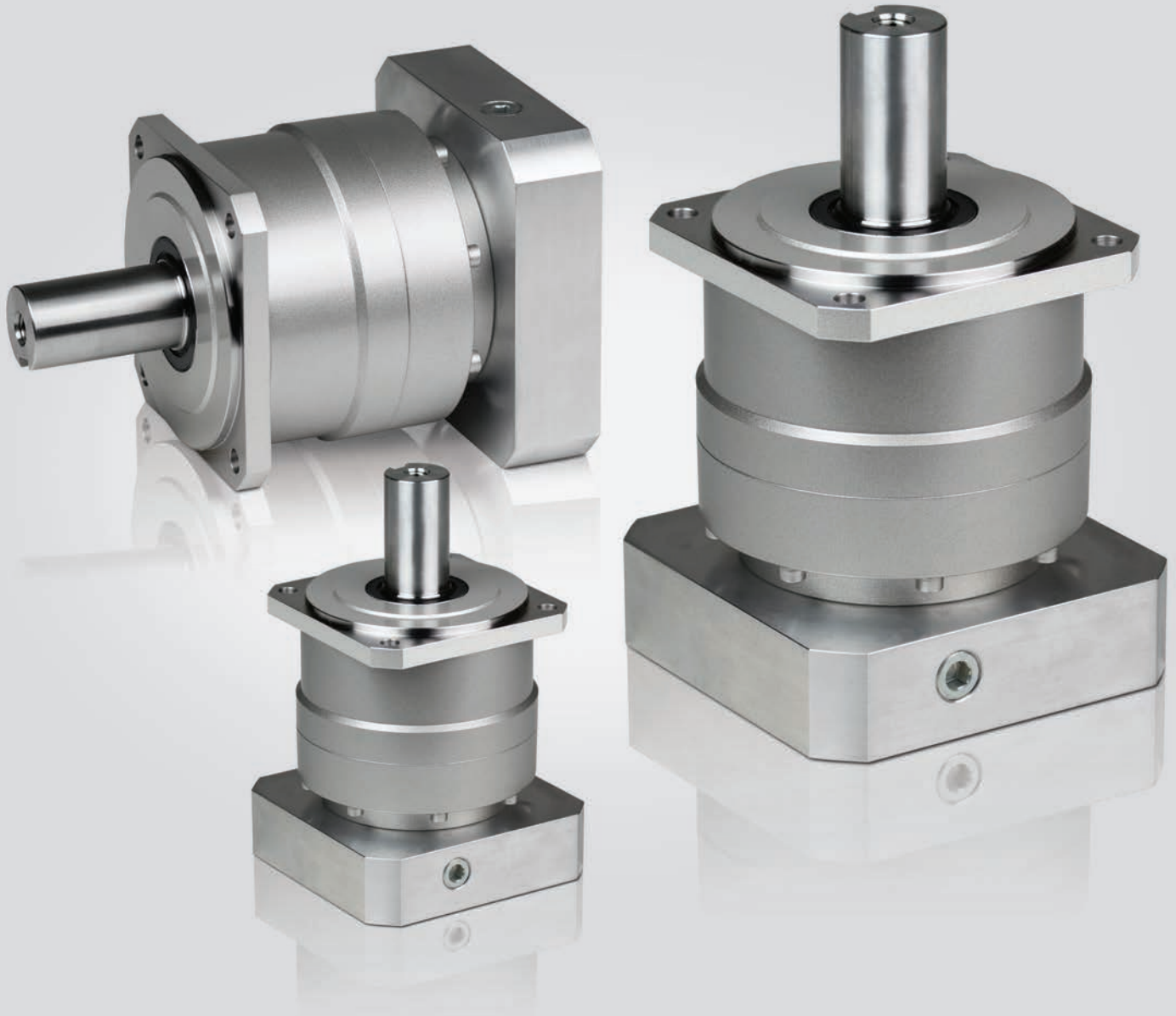

VRB SERIES

- Exceptional value for high end motion control applications with demanding accuracy requirements
- The widest range of frame sizes and ratios available in the market
- Best-In-class backlash (≤ 3 arc-min)
- Broad range of mounting adapters offer a simple, precise attachment to any motor
- Maintenance-free solution that is lubricated for life. High performance grease allows flexible mounting in any orientation
- Industry standard through-bolt mounting style
- Assembled in the USA, with immediate delivery

PLANETARY *Inline Gear Reducers*

VRB Series Features

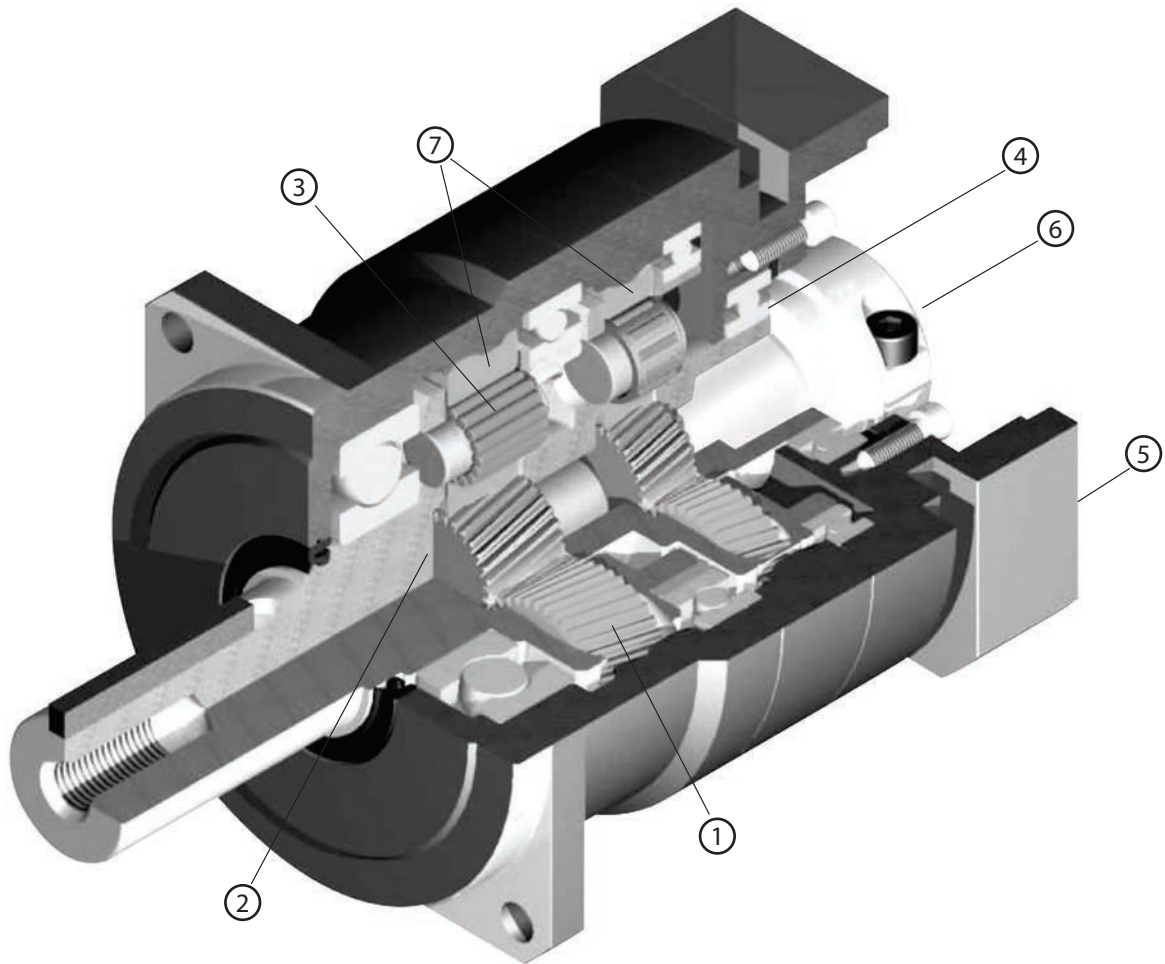

- ① Carburized helical gears with proprietary secondary finishing process for higher accuracy and smooth, quiet operation. 40% higher tooth surface area than the industry standard
- ② One piece output shaft and planet carrier with two bearings straddling the planet gears. Higher stiffness, torque capacity and safety factor, with guaranteed alignment of gearing
- ③ Uncaged needle roller bearings provide excellent torque density and torsional rigidity. 43% larger bearing surface area compared to the rest of the industry
- ④ Unique labyrinth input seal design greatly reduces heat and increases system efficiency. IP65 protection is available for wash down applications
- ⑤ Optimized mounting system with active centering on motor pilot diameter guarantees alignment of motor. Motor can be installed in any orientation
- ⑥ True concentric motor shaft clamping connection, optimized for your specific motor. Reduced inertia for dynamic performance and balanced for high speed operation
- ⑦ Ring gear machined directly into the housing, not welded or pressed in. Provides greater concentricity and elimination of speed fluctuation

VRB Series Model Code

VRB	090	C	7	K	3	19HB16
Series Name	Frame Size	Design Version	Ratio	Output Mounting Style	Backlash	Motor Mounting Code
VRB	042 060 090 115 140 180 220	Design Version	1 Stage: 3 4 5 6 7 8 9 10 2 Stage: 15 16 20 25 28 30 35 40 45 50 60 70 80 90 100	K: Keyed Shaft S: Smooth shaft	≤3 arc-min	Motor mounting code varies depending on the motor

* Use the selection tool link below to configure the code

Contact us for additional information or refer to our online gearhead selection tool.
 Selection tool <https://www.nidec-drivetechnology.co.jp/selection/all/>

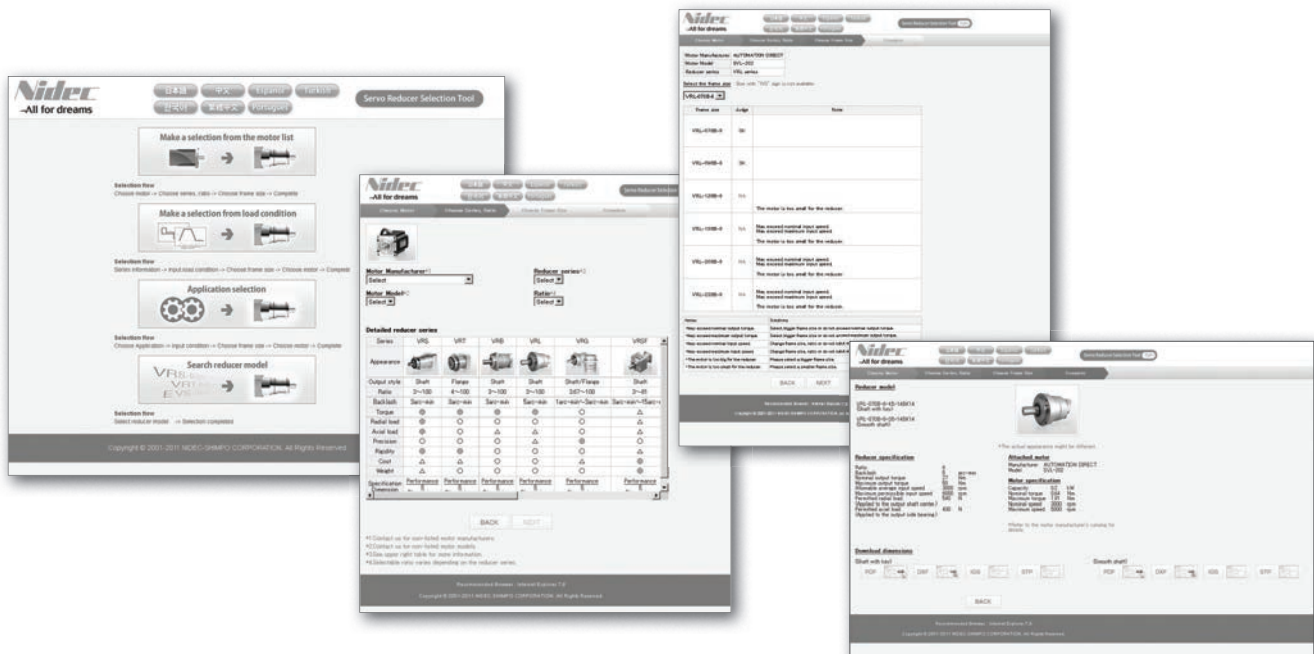

VRSF
PRE
PRF
VRL
VRB
VRS
VRT

VRB 042 1-Stage Specifications

Frame Size	042									
Ratio	Units	Notes	3	4	5	6	7	8	9	10
Nominal Output Torque	[Nm]	*1	6	9	10	10	10	10	10	10
Maximum Acceleration Torque	[Nm]	*2	14	21	21	21	21	21	14	14
Maximum Torque	[Nm]	*3	17	25	25	25	25	25	17	17
Emergency Stop Torque	[Nm]	*4	30	35	35	35	35	35	30	30
Nominal Input Speed	[rpm]	*5	4000	4000	4000	4000	4000	4000	4000	4000
Maximum Input Speed	[rpm]	*6	8000	8000	8000	8000	8000	8000	8000	8000
No Load Running Torque	[Nm]	*7	0.03							
Maximum Radial Load	[N]	*8	710							
Maximum Axial Load	[N]	*9	640							
Moment of Inertia ($\leq \varnothing 8$)	[kgcm ²]	--	0.053	0.041	0.036	0.034	0.032	0.031	0.031	0.030
Moment of Inertia ($\leq \varnothing 14$)	[kgcm ²]	--	0.17	0.16	0.15	0.15	0.15	0.15	0.15	0.15
Efficiency	[%]	*10	95							
Torsional Rigidity	[Nm/arc-min]	*11	2							
Maximum Torsional Backlash	[arc-min]	--	≤ 3							
Noise Level	dB [A]	*12	≤ 61							
Protection Class	--	*13	IP54 (IP65)							
Ambient Temperature	[°C]	--	0-40							
Permitted Housing Temperature	[°C]	--	90							
Weight	[kg]	*14	0.6							

VRB 042 2-Stage Specifications

Frame Size	042									
Ratio	Units	Notes	15	16	20	25	28	30	35	40
Nominal Output Torque	[Nm]	*1	9	14	14	15	15	11	15	15
Maximum Acceleration Torque	[Nm]	*2	14	21	21	21	21	14	21	21
Maximum Torque	[Nm]	*3	14	21	21	21	21	14	21	21
Emergency Stop Torque	[Nm]	*4	30	35	35	35	35	30	35	35
Nominal Input Speed	[rpm]	*5	4000	4000	4000	4000	4000	4000	4000	4000
Maximum Input Speed	[rpm]	*6	8500	8500	8500	8500	8500	8500	8500	8500
No Load Running Torque	[Nm]	*7	0.01							
Maximum Radial Load	[N]	*8	710							
Maximum Axial Load	[N]	*9	640							
Moment of Inertia ($\leq \varnothing 8$)	[kgcm ²]	--	0.035	0.038	0.034	0.034	0.038	0.030	0.034	0.030
Moment of Inertia ($\leq \varnothing 14$)	[kgcm ²]	--	--	--	--	--	--	--	--	--
Efficiency	[%]	*10	90							
Torsional Rigidity	[Nm/arc-min]	*11	2							
Maximum Torsional Backlash	[arc-min]	--	≤ 5							
Noise Level	dB [A]	*12	≤ 61							
Protection Class	--	*13	IP54 (IP65)							
Ambient Temperature	[°C]	--	0-40							
Permitted Housing Temperature	[°C]	--	90							
Weight	[kg]	*14	0.7							

VRB 042 2-Stage Specifications

Frame Size	042								
Ratio	Units	Notes	45	50	60	70	80	90	100
Nominal Output Torque	[Nm]	*1	11	15	15	15	15	11	11
Maximum Acceleration Torque	[Nm]	*2	14	21	21	21	21	14	14
Maximum Torque	[Nm]	*3	14	21	21	21	21	14	14
Emergency Stop Torque	[Nm]	*4	30	35	35	35	35	30	30
Nominal Input Speed	[rpm]	*5	4000	4000	4000	4000	4000	4000	4000
Maximum Input Speed	[rpm]	*6	8500	8500	8500	8500	8500	8500	8500
No Load Running Torque	[Nm]	*7	0.01						
Maximum Radial Load	[N]	*8	710						
Maximum Axial Load	[N]	*9	640						
Moment of Inertia ($\leq \varnothing 8$)	[kgcm ²]	--	0.034	0.030	0.030	0.030	0.030	0.030	0.030
Moment of Inertia ($\leq \varnothing 14$)	[kgcm ²]	--	--	--	--	--	--	--	--
Efficiency	[%]	*10	90						
Torsional Rigidity	[Nm/arc-min]	*11	2						
Maximum Torsional Backlash	[arc-min]	--	≤ 5						
Noise Level	dB [A]	*12	≤ 61						
Protection Class	--	*13	IP54 (IP65)						
Ambient Temperature	[°C]	--	0-40						
Permitted Housing Temperature	[°C]	--	90						
Weight	[kg]	*14	0.7						

*1 At nominal input speed, service life is 20,000 hours

*2 The maximum torque when starting or stopping operation. Apply Cycle Factor f_0 , found on page 468, for higher duty cycle applications

*3 Permitted 10,000 times during service life. Based on 10% of maximum radial load and smooth output shaft

*4 The maximum torque allowed under a stress situation. Permitted 1,000 times during service life

*5 The average input speed at nominal input torque. Maintain housing temperature below permitted value

*6 The maximum intermittent input speed

*7 Torque at no load applied to the input shaft at nominal input speed

*8 The maximum radial load that the gearbox can accept

*9 The maximum axial load that the gearbox can accept

*10 The efficiency at the nominal output torque rating

*11 This does not include lost motion

*12 Contact Nidec Drive Technology for the testing conditions and environment

*13 IP65 (wash-down) is available as an option. Contact Nidec Drive Technology for more details

*14 Weight may vary slightly between models

VRSF

PRE

PRF

VRL

VRB

VR5

VRT

PLANETARY Inline Gear Reducers

VRB 042 1-Stage Dimensions

Input bore size $\leq \phi 8$ mm

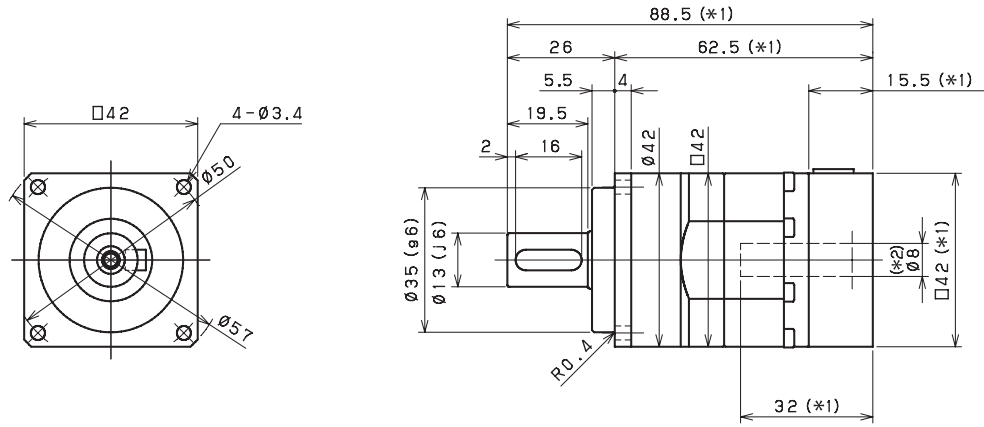

Input bore size $\leq \phi 14$ mm

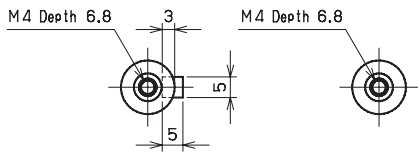
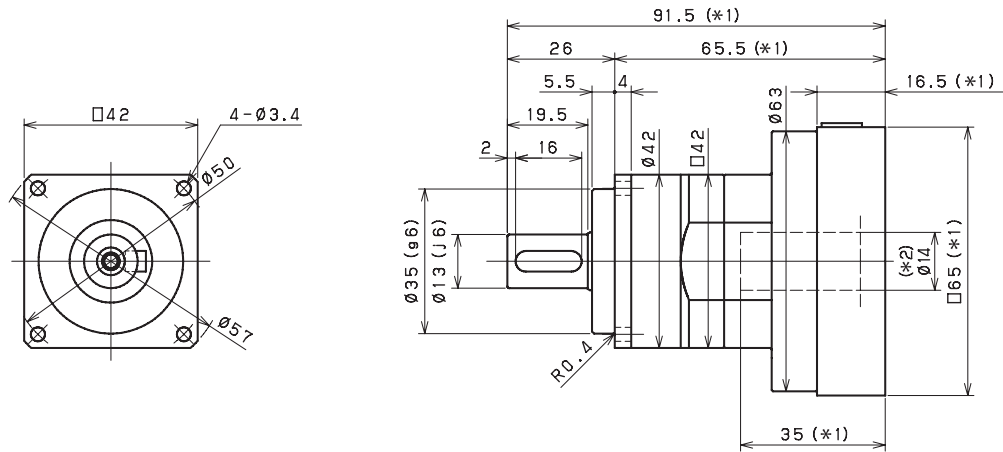

Keyed shaft

Smooth shaft

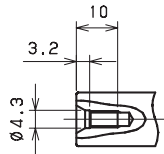

*1 Length will vary depending on motor

*2 Bushing will be inserted to adapt to motor shaft

VRB 042 2-Stage Dimensions

Input bore size $\leq \varnothing 8$ mm

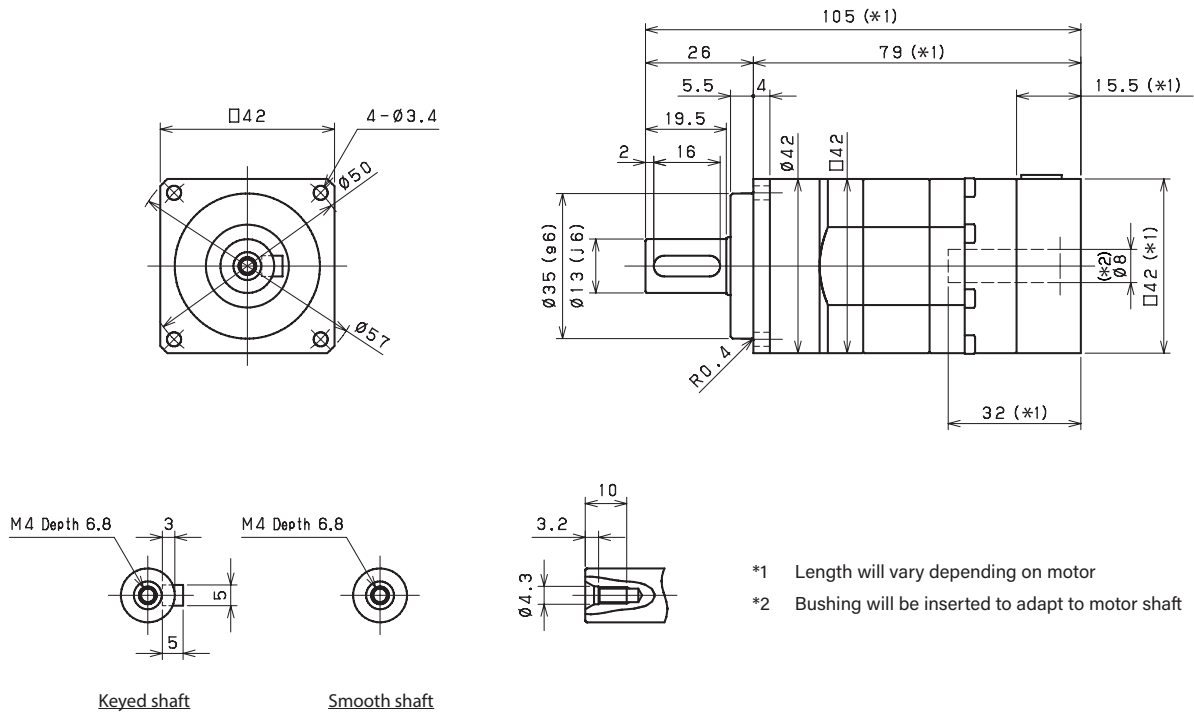

- *1 Length will vary depending on motor
- *2 Bushing will be inserted to adapt to motor shaft

VRB Series
VRT
VRS
VRB
VRL
PRF
PRE
VRSF

VRB 060 1-Stage Specifications

Frame Size	060									
Ratio	Unit	Note	3	4	5	6	7	8	9	10
Nominal Output Torque	[Nm]	*1	19	27	28	28	28	28	28	28
Maximum Acceleration Torque	[Nm]	*2	46	66	66	66	66	66	46	46
Maximum Torque	[Nm]	*3	55	79	79	79	79	76	55	55
Emergency Stop Torque	[Nm]	*4	80	100	100	100	100	100	80	80
Nominal Input Speed	[rpm]	*5	3300	3300	4000	4000	4000	4000	4000	4000
Maximum Input Speed	[rpm]	*6	7500	7500	7500	7500	7500	7500	7500	7500
No Load Running Torque	[Nm]	*7	0.15							
Maximum Radial Load	[N]	*8	1200							
Maximum Axial Load	[N]	*9	1100							
Moment of Inertia ($\leq \varnothing 8$)	[kgcm ²]	--	0.14	0.095	0.077	0.068	0.062	0.059	0.057	0.056
Moment of Inertia ($\leq \varnothing 14$)	[kgcm ²]	--	0.25	0.21	0.19	0.18	0.17	0.17	0.17	0.17
Moment of Inertia ($\leq \varnothing 19$)	[kgcm ²]	--	0.53	0.48	0.46	0.46	0.45	0.45	0.44	0.44
Efficiency	[%]	*10	95							
Torsional Rigidity	[Nm/arc-min]	*11	3							
Maximum Torsional Backlash	[arc-min]	--	≤ 3							
Noise Level	dB [A]	*12	≤ 66							
Protection Class	--	*13	IP54 (IP65)							
Ambient Temperature	[°C]	--	0-40							
Permitted Housing Temperature	[°C]	--	90							
Weight	[kg]	*14	1.4							

VRB 060 2-Stage Specifications

Frame Size	060									
Ratio	Unit	Note	15	16	20	25	28	30	35	40
Nominal Output Torque	[Nm]	*1	25	32	32	43	45	32	45	45
Maximum Acceleration Torque	[Nm]	*2	46	66	66	66	66	46	66	66
Maximum Torque	[Nm]	*3	46	66	66	66	66	46	66	66
Emergency Stop Torque	[Nm]	*4	80	100	100	100	100	80	100	100
Nominal Input Speed	[rpm]	*5	4000	4000	4000	4000	4000	4000	4000	4000
Maximum Input Speed	[rpm]	*6	8500	8500	8500	8500	8500	8500	8500	8500
No Load Running Torque	[Nm]	*7	0.04							
Maximum Radial Load	[N]	*8	1200							
Maximum Axial Load	[N]	*9	1100							
Moment of Inertia ($\leq \varnothing 8$)	[kgcm ²]	--	0.064	0.070	0.062	0.061	0.068	0.051	0.061	0.051
Moment of Inertia ($\leq \varnothing 14$)	[kgcm ²]	--	0.18	0.18	0.17	0.17	0.18	0.16	0.17	0.16
Moment of Inertia ($\leq \varnothing 19$)	[kgcm ²]	--	0.45	0.46	0.45	0.45	0.46	0.44	0.45	0.44
Efficiency	[%]	*10	90							
Torsional Rigidity	[Nm/arc-min]	*11	3							
Maximum Torsional Backlash	[arc-min]	--	≤ 3							
Noise Level	dB [A]	*12	≤ 66							
Protection Class	--	*13	IP54 (IP65)							
Ambient Temperature	[°C]	--	0-40							
Permitted Housing Temperature	[°C]	--	90							
Weight	[kg]	*14	1.6							

VRB 060 2-Stage Specifications

Frame Size	060										
Ratio	Unit	Note	45	50	60	70	80	90	100		
Nominal Output Torque	[Nm]	*1	32	45	45	45	45	32	32		
Maximum Acceleration Torque	[Nm]	*2	46	66	66	66	66	46	46		
Maximum Torque	[Nm]	*3	46	66	66	66	66	46	46		
Emergency Stop Torque	[Nm]	*4	80	100	100	100	100	80	80		
Nominal Input Speed	[rpm]	*5	4000	4800	4800	5500	5500	5500	5500		
Maximum Input Speed	[rpm]	*6	8500	8500	8500	8500	8500	8500	8500		
No Load Running Torque	[Nm]	*7	0.04								
Maximum Radial Load	[N]	*8	1200								
Maximum Axial Load	[N]	*9	1100								
Moment of Inertia ($\leq \varnothing 8$)	[kgcm ²]	--	0.061	0.051	0.051	0.051	0.051	0.051	0.051		
Moment of Inertia ($\leq \varnothing 14$)	[kgcm ²]	--	0.17	0.16	0.16	0.16	0.16	0.16	0.16		
Moment of Inertia ($\leq \varnothing 19$)	[kgcm ²]	--	0.45	0.44	0.44	0.44	0.44	0.44	0.44		
Efficiency	[%]	*10	90								
Torsional Rigidity	[Nm/arc-min]	*11	3								
Maximum Torsional Backlash	[arc-min]	--	≤ 3								
Noise Level	dB [A]	*12	≤ 66								
Protection Class	--	*13	IP54 (IP65)								
Ambient Temperature	[°C]	--	0-40								
Permitted Housing Temperature	[°C]	--	90								
Weight	[kg]	*14	1.6								

*1 At nominal input speed, service life is 20,000 hours

*2 The maximum torque when starting or stopping operation. Apply Cycle Factor f_0 , found on page 468, for higher duty cycle applications

*3 Permitted 10,000 times during service life. Based on 10% of maximum radial load and smooth output shaft

*4 The maximum torque allowed under a stress situation. Permitted 1,000 times during service life

*5 The average input speed at nominal input torque. Maintain housing temperature below permitted value

*6 The maximum intermittent input speed

*7 Torque at no load applied to the input shaft at nominal input speed

*8 The maximum radial load that the gearbox can accept

*9 The maximum axial load that the gearbox can accept

*10 The efficiency at the nominal output torque rating

*11 This does not include lost motion

*12 Contact Nidec Drive Technology for the testing conditions and environment

*13 IP65 (wash-down) is available as an option. Contact Nidec Drive Technology for more details

*14 Weight may vary slightly between models

VRSF

PRE

PRF

VRL

VRB

VR5

VRT

PLANETARY Inline Gear Reducers

VRB 060 1-Stage Dimensions

Input bore size $\leq \varnothing 8$ mm

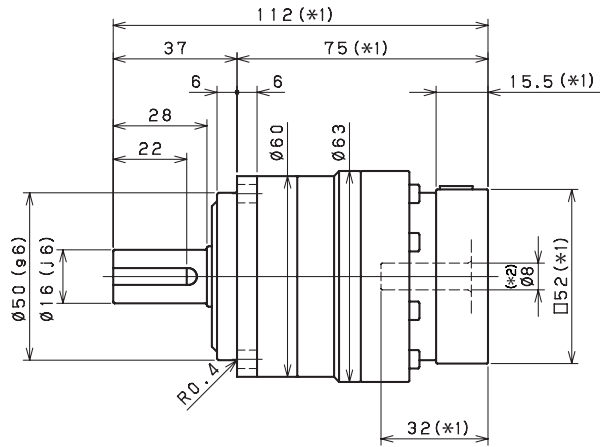
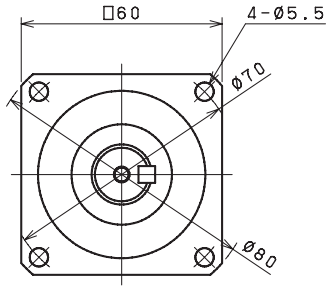

Input bore size $\leq \varnothing 14$ mm

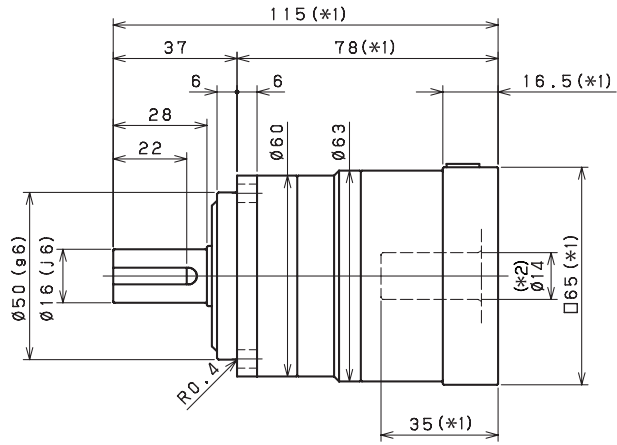
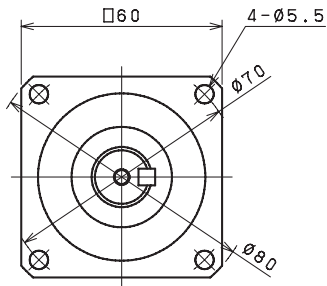

Input bore size $\leq \varnothing 19$ mm

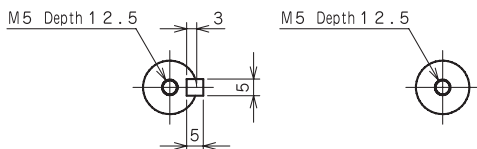
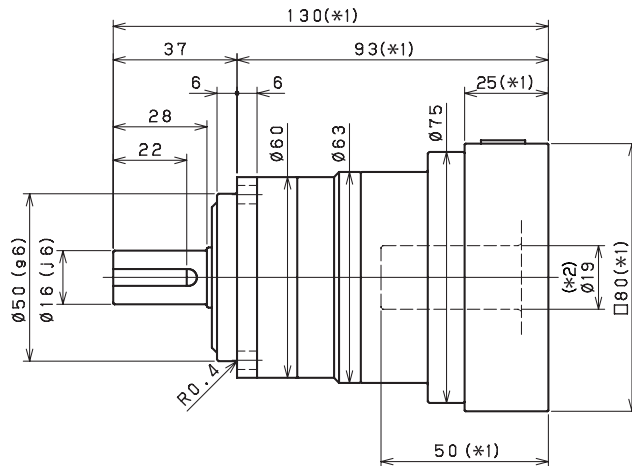
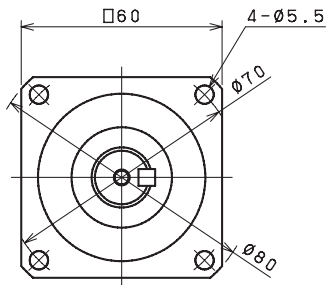

Keyed shaft

Smooth shaft

*1 Length will vary depending on motor

*2 Bushing will be inserted to adapt to motor shaft

VRB 060 2-Stage Dimensions

Input bore size $\leq \phi 8$ mm

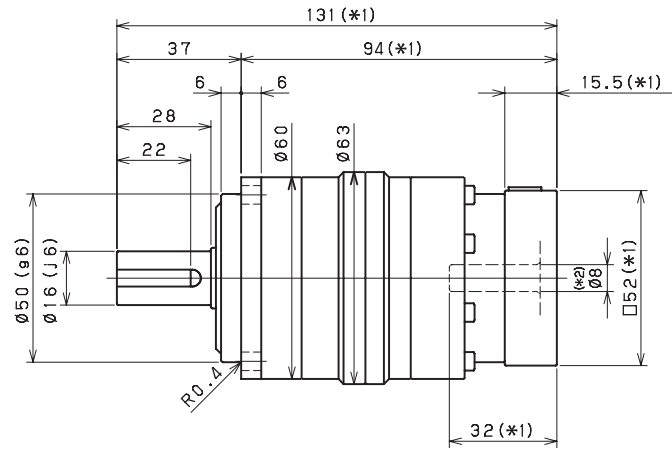
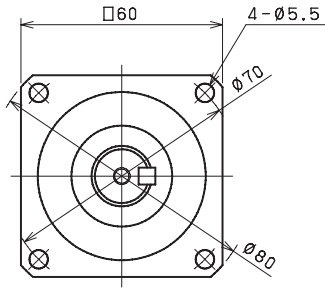

Input bore size $\leq \phi 14$ mm

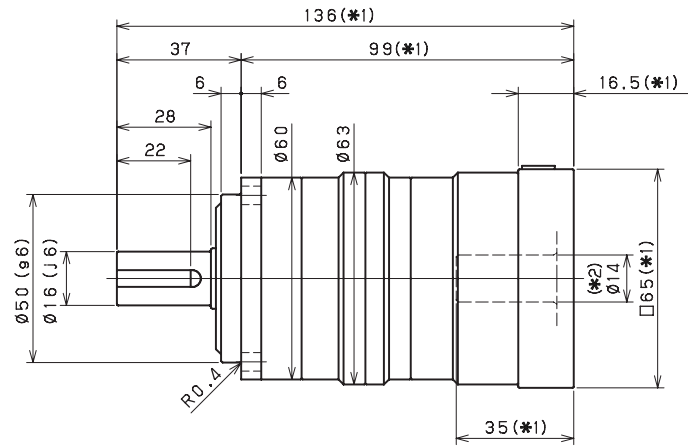
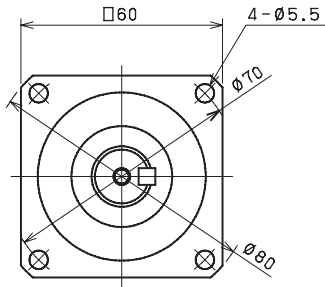

Input bore size $\leq \phi 19$ mm

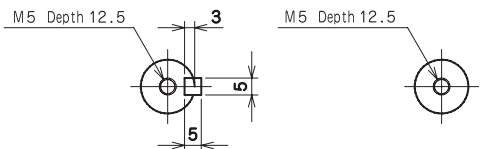
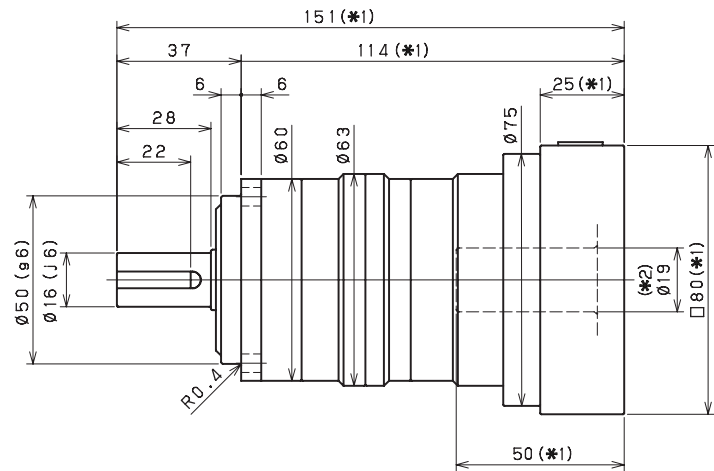
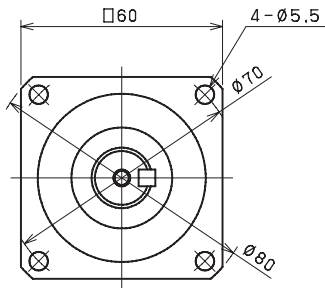

Keyed shaft

Smooth shaft

*1 Length will vary depending on motor

*2 Bushing will be inserted to adapt to motor shaft

VRSF

PRE

PRF

VRL

VRB

VR5

VRT

VRB 090 1-Stage Specifications

Frame Size	090									
Ratio	Unit	Note	3	4	5	6	7	8	9	10
Nominal Output Torque	[Nm]	*1	53	77	84	84	84	84	84	84
Maximum Acceleration Torque	[Nm]	*2	108	165	165	165	165	165	112	112
Maximum Torque	[Nm]	*3	135	200	200	195	195	190	145	145
Emergency Stop Torque	[Nm]	*4	200	250	250	250	250	250	200	200
Nominal Input Speed	[rpm]	*5	2900	2900	2900	2900	3100	3100	3100	3100
Maximum Input Speed	[rpm]	*6	7500	7500	7500	7500	7500	7500	7500	7500
No Load Running Torque	[Nm]	*7	0.35							
Maximum Radial Load	[N]	*8	2400							
Maximum Axial Load	[N]	*9	2200							
Moment of Inertia ($\leq \varnothing 8$)	[kgcm ²]	--	--	--	--	--	--	--	--	--
Moment of Inertia ($\leq \varnothing 14$)	[kgcm ²]	--	0.72	0.50	0.41	0.36	0.33	0.31	0.30	0.30
Moment of Inertia ($\leq \varnothing 19$)	[kgcm ²]	--	1.1	0.90	0.80	0.75	0.73	0.71	0.70	0.70
Moment of Inertia ($\leq \varnothing 28$)	[kgcm ²]	--	2.9	2.7	2.6	2.5	2.5	2.5	2.5	2.5
Efficiency	[%]	*10	95							
Torsional Rigidity	[Nm/arc-min]	*11	10							
Maximum Torsional Backlash	[arc-min]	--	≤ 3							
Noise Level	dB [A]	*12	≤ 67							
Protection Class	--	*13	IP54 (IP65)							
Ambient Temperature	[°C]	--	0-40							
Permitted Housing Temperature	[°C]	--	90							
Weight	[kg]	*14	3.7							

VRB 090 2-Stage Specifications

Frame Size	090									
Ratio	Unit	Note	15	16	20	25	28	30	35	40
Nominal Output Torque	[Nm]	*1	65	80	86	106	118	88	118	118
Maximum Acceleration Torque	[Nm]	*2	108	165	165	165	165	108	165	165
Maximum Torque	[Nm]	*3	108	165	165	165	165	108	165	165
Emergency Stop Torque	[Nm]	*4	200	250	250	250	250	200	250	250
Nominal Input Speed	[rpm]	*5	3500	3500	3500	3500	3500	3500	3500	3500
Maximum Input Speed	[rpm]	*6	8500	8500	8500	8500	8500	8500	8500	8500
No Load Running Torque	[Nm]	*7	0.06							
Maximum Radial Load	[N]	*8	2400							
Maximum Axial Load	[N]	*9	2200							
Moment of Inertia ($\leq \varnothing 8$)	[kgcm ²]	--	0.20	0.25	0.19	0.19	0.24	0.12	0.18	0.11
Moment of Inertia ($\leq \varnothing 14$)	[kgcm ²]	--	0.36	0.41	0.35	0.35	0.4	0.28	0.35	0.28
Moment of Inertia ($\leq \varnothing 19$)	[kgcm ²]	--	0.75	0.79	0.74	0.74	0.78	0.67	0.73	0.67
Moment of Inertia ($\leq \varnothing 28$)	[kgcm ²]	--	2.5	2.5	2.5	2.5	2.5	2.4	2.5	2.4
Efficiency	[%]	*10	90							
Torsional Rigidity	[Nm/arc-min]	*11	10							
Maximum Torsional Backlash	[arc-min]	--	≤ 3							
Noise Level	dB [A]	*12	≤ 67							
Protection Class	--	*13	IP54 (IP65)							
Ambient Temperature	[°C]	--	0-40							
Permitted Housing Temperature	[°C]	--	90							
Weight	[kg]	*14	4.2							

VRB 090 2-Stage Specifications

Frame Size	090										
Ratio	Unit	Note	45	50	60	70	80	90	100		
Nominal Output Torque	[Nm]	*1	88	118	118	118	118	88	88		
Maximum Acceleration Torque	[Nm]	*2	112	165	165	165	165	112	112		
Maximum Torque	[Nm]	*3	112	165	165	165	165	112	112		
Emergency Stop Torque	[Nm]	*4	200	250	250	250	250	200	200		
Nominal Input Speed	[rpm]	*5	3500	3800	3800	4500	4500	4500	4500		
Maximum Input Speed	[rpm]	*6	8500	8500	8500	8500	8500	8500	8500		
No Load Running Torque	[Nm]	*7	0.06								
Maximum Radial Load	[N]	*8	2400								
Maximum Axial Load	[N]	*9	2200								
Moment of Inertia ($\leq \varnothing 8$)	[kgcm ²]	--	0.18	0.11	0.11	0.11	0.11	0.11	0.11		
Moment of Inertia ($\leq \varnothing 14$)	[kgcm ²]	--	0.34	0.27	0.27	0.27	0.27	0.27	0.27		
Moment of Inertia ($\leq \varnothing 19$)	[kgcm ²]	--	0.73	0.67	0.67	0.67	0.67	0.67	0.67		
Moment of Inertia ($\leq \varnothing 28$)	[kgcm ²]	--	2.5	2.4	2.4	2.4	2.4	2.4	2.4		
Efficiency	[%]	*10	90								
Torsional Rigidity	[Nm/arc-min]	*11	10								
Maximum Torsional Backlash	[arc-min]	--	≤ 3								
Noise Level	dB [A]	*12	≤ 67								
Protection Class	--	*13	IP54 (IP65)								
Ambient Temperature	[°C]	--	0-40								
Permitted Housing Temperature	[°C]	--	90								
Weight	[kg]	*14	4.2								

*1 At nominal input speed, service life is 20,000 hours

*2 The maximum torque when starting or stopping operation. Apply Cycle Factor f_0 , found on page 468, for higher duty cycle applications

*3 Permitted 10,000 times during service life. Based on 10% of maximum radial load and smooth output shaft

*4 The maximum torque allowed under a stress situation. Permitted 1,000 times during service life

*5 The average input speed at nominal input torque. Maintain housing temperature below permitted value

*6 The maximum intermittent input speed

*7 Torque at no load applied to the input shaft at nominal input speed

*8 The maximum radial load that the gearbox can accept

*9 The maximum axial load that the gearbox can accept

*10 The efficiency at the nominal output torque rating

*11 This does not include lost motion

*12 Contact Nidec Drive Technology for the testing conditions and environment

*13 IP65 (wash-down) is available as an option. Contact Nidec Drive Technology for more details

*14 Weight may vary slightly between models

VRSF

PRE

PRF

VRL

VRB

VRS

VRT

PLANETARY Inline Gear Reducers

VRB 090 1-Stage Dimensions

Input bore size $\leq \phi 14$ mm

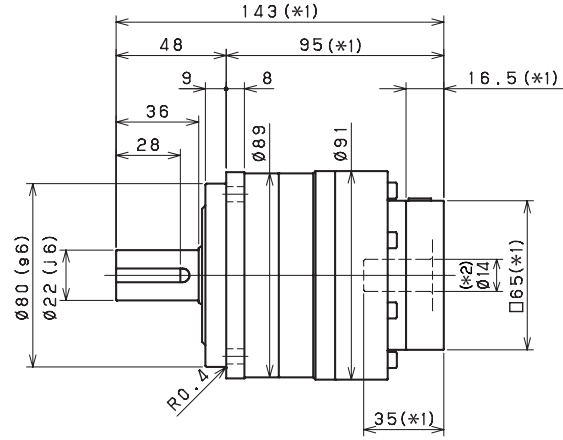
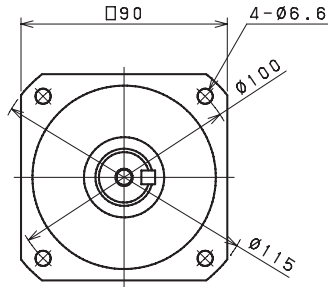

Input bore size $\leq \phi 19$ mm

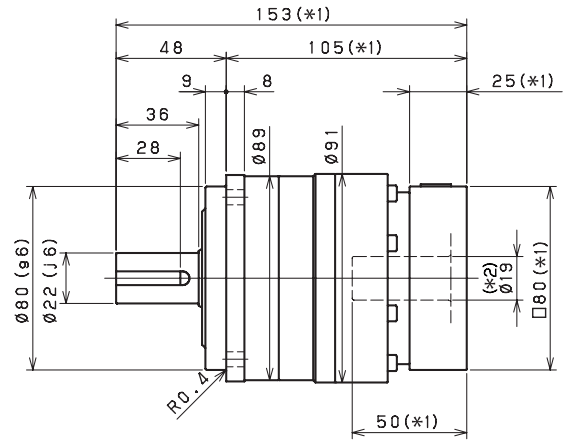
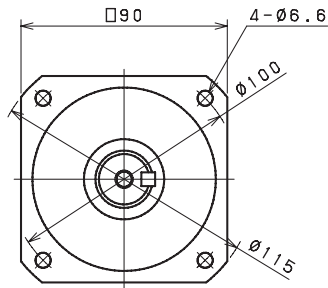

Input bore size $\leq \phi 28$ mm

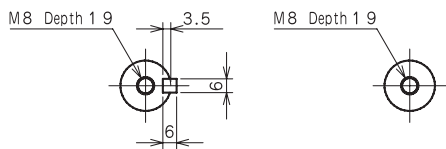
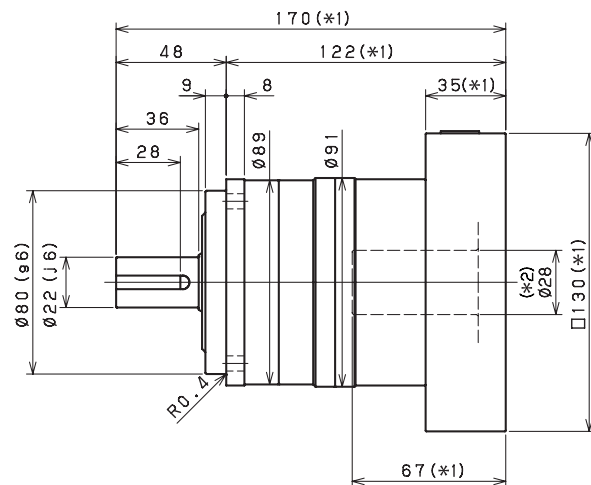
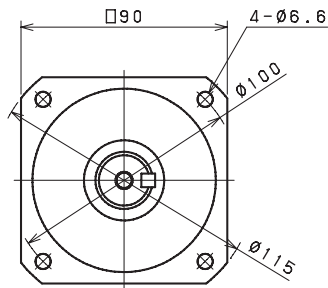

Keyed shaft

Smooth shaft

*1 Length will vary depending on motor

*2 Bushing will be inserted to adapt to motor shaft

VRB 090 2-Stage Dimensions

Input bore size $\leq \varnothing 8 \text{ mm}$

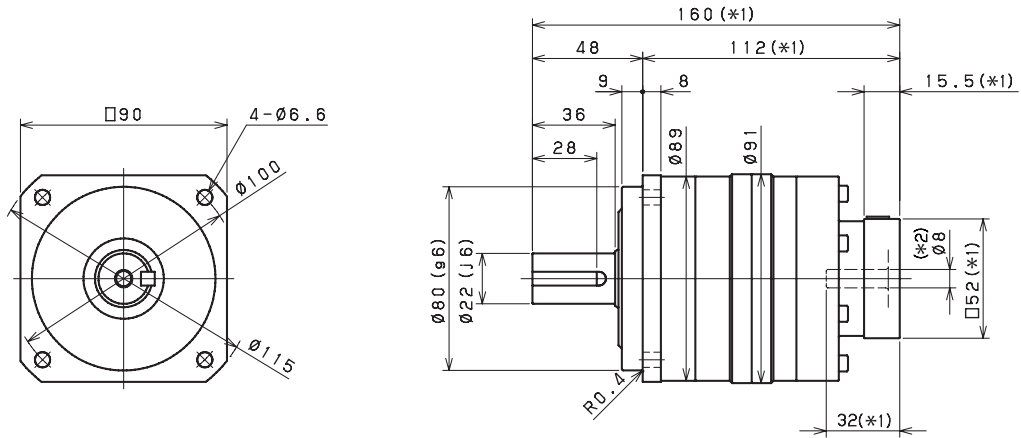

Input bore size $\leq \varnothing 14 \text{ mm}$

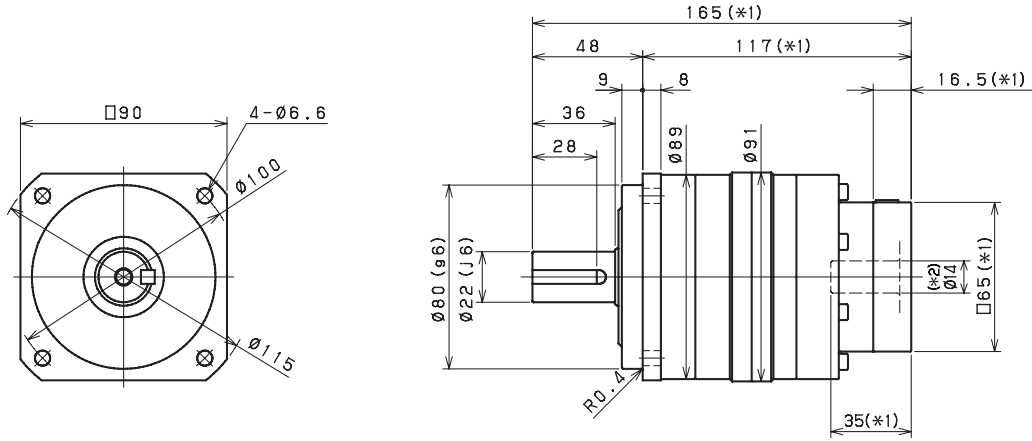

Input bore size $\leq \varnothing 19 \text{ mm}$ ^(*3)

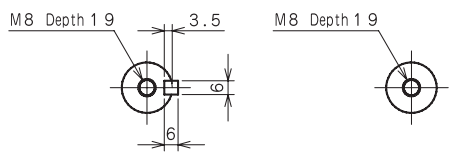
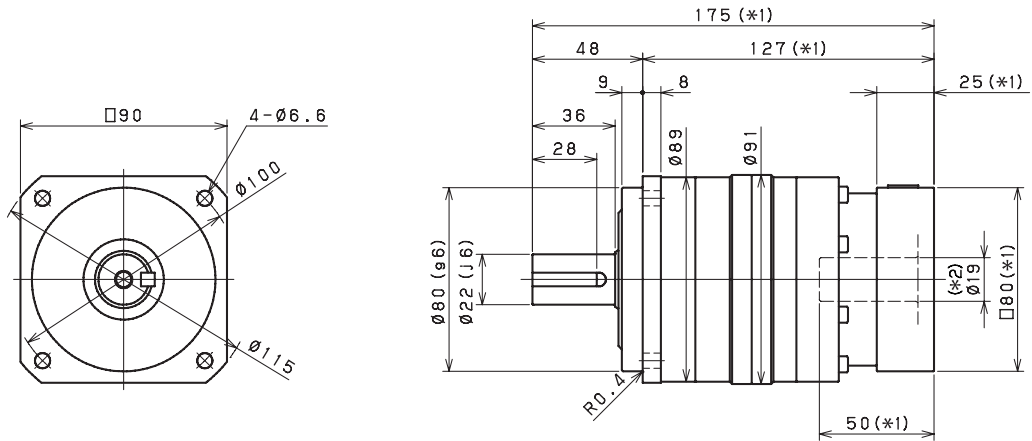

Keyed shaft

Smooth shaft

*1 Length will vary depending on motor

*2 Bushing will be inserted to adapt to motor shaft

*3 28mm input bore is available for this frame size. Use our online configurator to make your selection or contact us for assistance

VRSF

PRE

PRF

VRL

VRB

VR5

VRT

VRB 115 1-Stage Specifications

Frame Size	115									
Ratio	Unit	Note	3	4	5	6	7	8	9	10
Nominal Output Torque	[Nm]	*1	128	146	190	190	190	190	190	190
Maximum Acceleration Torque	[Nm]	*2	270	390	390	390	390	390	292	292
Maximum Torque (new)	--	*3	340	490	490	480	480	480	370	370
Emergency Stop Torque	[Nm]	*4	500	625	625	625	625	625	500	500
Nominal Input Speed	[rpm]	*5	2800	2800	2800	2800	2800	2800	2800	2800
Maximum Input Speed	[rpm]	*6	5500	5500	5500	5500	5500	5500	5500	5500
No Load Running Torque	[Nm]	*7	1.30							
Maximum Radial Load	[N]	*8	4300							
Maximum Axial Load	[N]	*9	3900							
Moment of Inertia ($\leq \varnothing 8$)	[kgcm ²]	--	--	--	--	--	--	--	--	--
Moment of Inertia ($\leq \varnothing 14$)	[kgcm ²]	--	--	--	--	--	--	--	--	--
Moment of Inertia ($\leq \varnothing 19$)	[kgcm ²]	--	3.2	2.0	1.4	1.2	1.0	0.92	0.86	0.83
Moment of Inertia ($\leq \varnothing 28$)	[kgcm ²]	--	5.1	3.7	3.1	2.9	2.8	2.7	2.6	2.6
Moment of Inertia ($\leq \varnothing 38$)	[kgcm ²]	--	12	10	9.5	9.3	9.1	9.0	8.9	8.9
Efficiency	[%]	*10	95							
Torsional Rigidity	[Nm/arc-min]	*11	31							
Maximum Torsional Backlash	[arc-min]	--	≤ 3							
Noise Level	dB [A]	*12	≤ 71							
Protection Class	--	*13	IP54 (IP65)							
Ambient Temperature	[°C]	--	0-40							
Permitted Housing Temperature	[°C]	--	90							
Weight	[kg]	*14	8							

VRB 115 2-Stage Specifications

Frame Size	115									
Ratio	Unit	Note	15	16	20	25	28	30	35	40
Nominal Output Torque	[Nm]	*1	174	200	220	280	280	220	280	270
Maximum Acceleration Torque	[Nm]	*2	270	390	390	390	390	270	390	390
Maximum Torque (new)	--	*3	270	390	390	390	390	270	390	390
Emergency Stop Torque	[Nm]	*4	500	625	625	625	625	500	625	625
Nominal Input Speed	[rpm]	*5	3100	3100	3100	3100	3100	3100	3100	3100
Maximum Input Speed	[rpm]	*6	6500	6500	6500	6500	6500	6500	6500	6500
No Load Running Torque	[Nm]	*7	0.42							
Maximum Radial Load	[N]	*8	4300							
Maximum Axial Load	[N]	*9	3900							
Moment of Inertia ($\leq \varnothing 8$)	[kgcm ²]	--	--	--	--	--	--	--	--	--
Moment of Inertia ($\leq \varnothing 14$)	[kgcm ²]	--	0.77	0.98	0.72	0.70	0.92	0.38	0.68	0.37
Moment of Inertia ($\leq \varnothing 19$)	[kgcm ²]	--	1.2	1.4	1.1	1.1	1.3	0.78	1.1	0.77
Moment of Inertia ($\leq \varnothing 28$)	[kgcm ²]	--	2.9	3.1	2.8	2.8	3.0	2.5	2.8	2.5
Moment of Inertia ($\leq \varnothing 38$)	[kgcm ²]	--	9.2	9.4	9.1	9.1	9.3	8.8	9.1	8.8
Efficiency	[%]	*10	90							
Torsional Rigidity	[Nm/arc-min]	*11	31							
Maximum Torsional Backlash	[arc-min]	--	≤ 3							
Noise Level	dB [A]	*12	≤ 71							
Protection Class	--	*13	IP54 (IP65)							
Ambient Temperature	[°C]	--	0-40							
Permitted Housing Temperature	[°C]	--	90							
Weight	[kg]	*14	8.9							

VRB 115 2-Stage Specifications

Frame Size	115										
Ratio	Unit	Note	45	50	60	70	80	90	100		
Nominal Output Torque	[Nm]	*1	220	280	280	280	280	220	220		
Maximum Acceleration Torque	[Nm]	*2	292	390	390	390	390	292	292		
Maximum Torque (new)	--	*3	292	390	390	390	390	292	292		
Emergency Stop Torque	[Nm]	*4	500	625	625	625	625	500	500		
Nominal Input Speed	[rpm]	*5	3100	3500	3500	4200	4200	4200	4200		
Maximum Input Speed	[rpm]	*6	6500	6500	6500	6500	6500	6500	6500		
No Load Running Torque	[Nm]	*7	0.42								
Maximum Radial Load	[N]	*8	4300								
Maximum Axial Load	[N]	*9	3900								
Moment of Inertia ($\leq \varnothing 8$)	[kgcm ²]	--	--	0.19	0.19	0.19	0.19	0.19	0.19		
Moment of Inertia ($\leq \varnothing 14$)	[kgcm ²]	--	0.68	0.36	0.36	0.36	0.36	0.36	0.36		
Moment of Inertia ($\leq \varnothing 19$)	[kgcm ²]	--	1.1	0.76	0.76	0.76	0.76	0.76	0.76		
Moment of Inertia ($\leq \varnothing 28$)	[kgcm ²]	--	2.8	2.5	2.5	2.5	2.5	2.5	2.5		
Moment of Inertia ($\leq \varnothing 38$)	[kgcm ²]	--	9.1	8.8	8.8	8.8	8.8	8.8	8.8		
Efficiency	[%]	*10	90								
Torsional Rigidity	[Nm/arc-min]	*11	31								
Maximum Torsional Backlash	[arc-min]	--	≤ 3								
Noise Level	dB [A]	*12	≤ 71								
Protection Class	--	*13	IP54 (IP65)								
Ambient Temperature	[°C]	--	0-40								
Permitted Housing Temperature	[°C]	--	90								
Weight	[kg]	*14	8.9								

- *1 At nominal input speed, service life is 20,000 hours
- *2 The maximum torque when starting or stopping operation. Apply Cycle Factor f_0 , found on page 468, for higher duty cycle applications
- *3 Permitted 10,000 times during service life. Based on 10% of maximum radial load and smooth output shaft
- *4 The maximum torque allowed under a stress situation. Permitted 1,000 times during service life
- *5 The average input speed at nominal input torque. Maintain housing temperature below permitted value
- *6 The maximum intermittent input speed
- *7 Torque at no load applied to the input shaft at nominal input speed
- *8 The maximum radial load that the gearbox can accept
- *9 The maximum axial load that the gearbox can accept
- *10 The efficiency at the nominal output torque rating
- *11 This does not include lost motion
- *12 Contact Nidec Drive Technology for the testing conditions and environment
- *13 IP65 (wash-down) is available as an option. Contact Nidec Drive Technology for more details
- *14 Weight may vary slightly between models

VRSF

PRE

PRF

VRL

VRB

VRS

VRT

PLANETARY Inline Gear Reducers

VRB 115 1-Stage Dimensions

Input bore size $\leq \phi 19$ mm

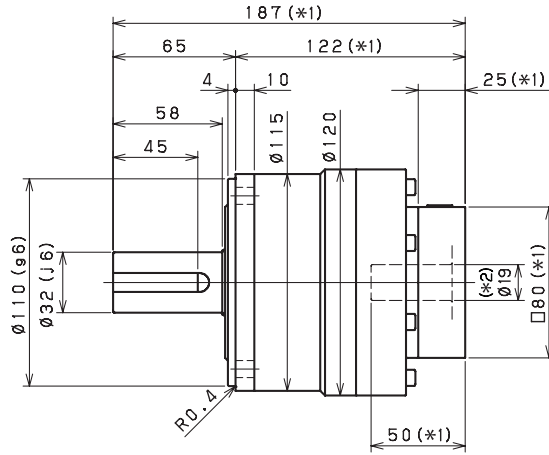
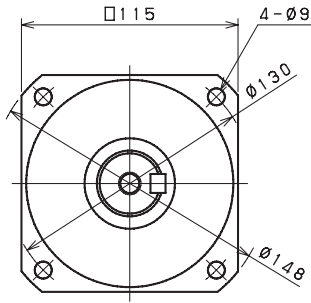

Input bore size $\leq \phi 28$ mm

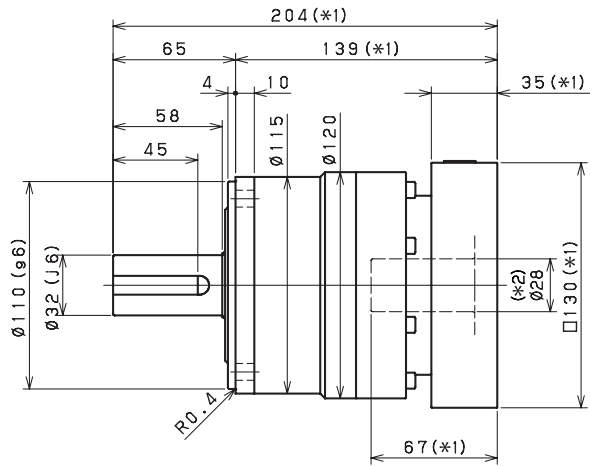
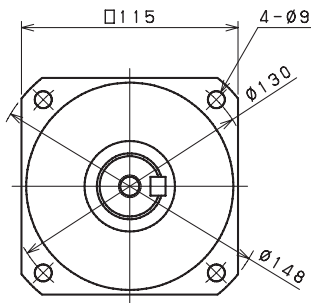

Input bore size $\leq \phi 38$ mm

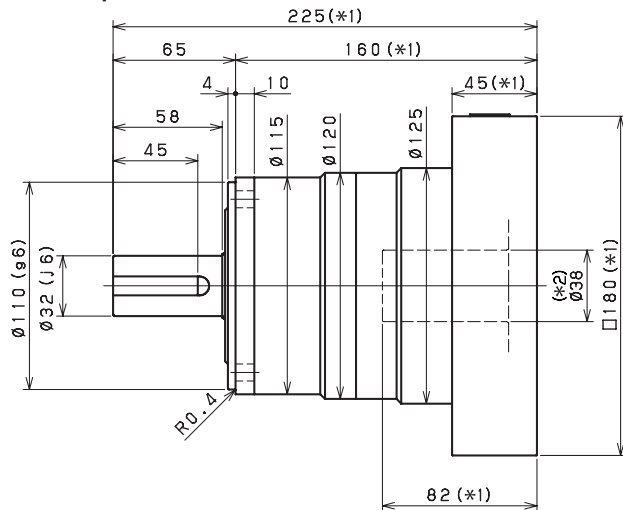
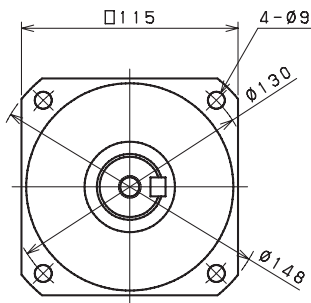

M12 Depth 2.8

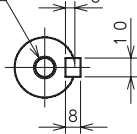

Keyed shaft

M12 Depth 2.8

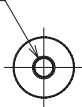

Smooth shaft

*1 Length will vary depending on motor

*2 Bushing will be inserted to adapt to motor shaft

VRB 115 2-Stage Dimensions

Input bore size $\leq \phi 14$ mm

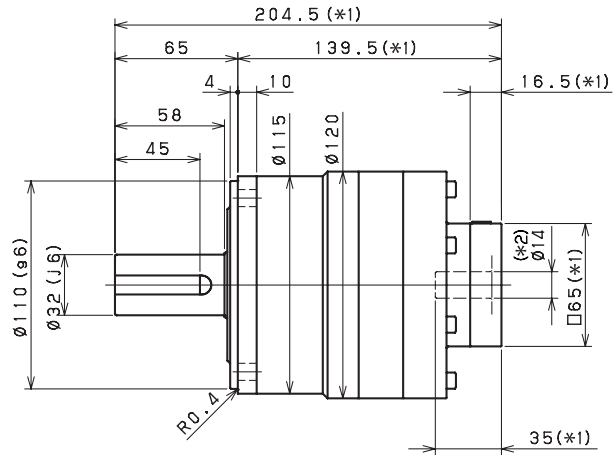
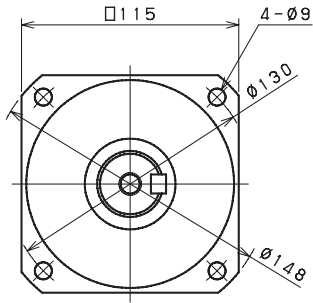

Input bore size $\leq \phi 19$ mm

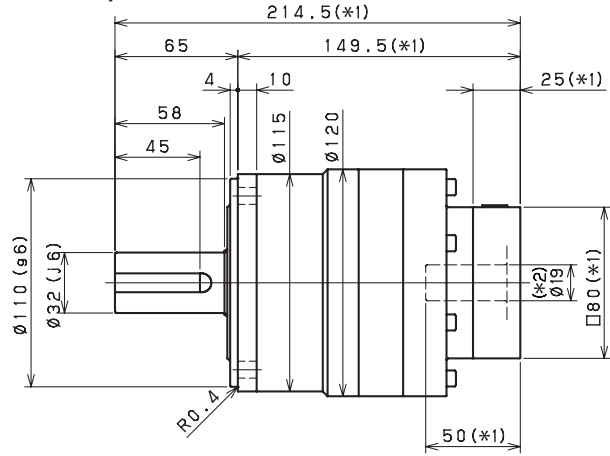
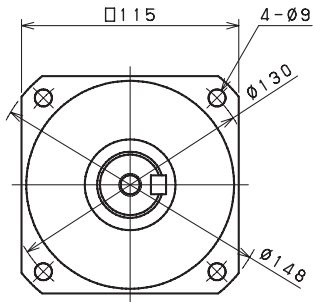

Input bore size $\leq \phi 28$ mm (*3)

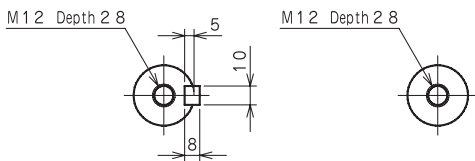
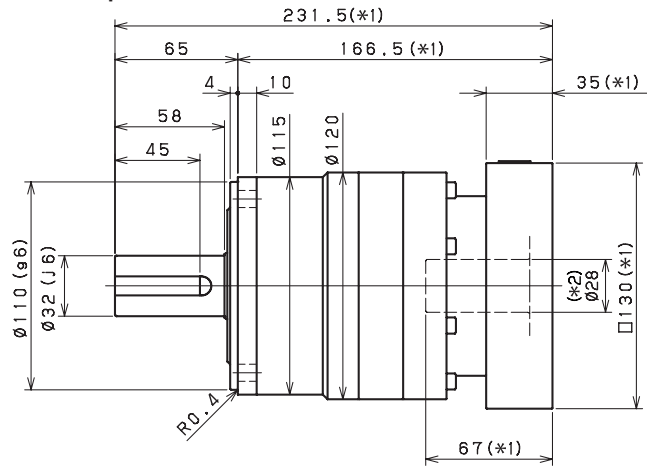
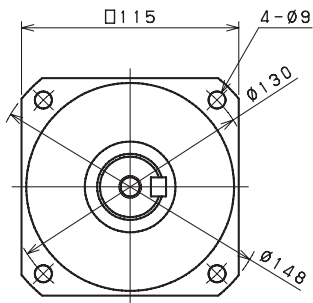

Keyed shaft

Smooth shaft

*1 Length will vary depending on motor

*2 Bushing will be inserted to adapt to motor shaft

*3 38mm input bore is available for this frame size. Use our online configurator to make your selection or contact us for assistance

VRSF

PRE

PRF

VR

VRB

VR

VRT

VRB 140 1-Stage Specifications

Frame Size	140									
Ratio	Unit	Note	3	4	5	6	7	8	9	10
Nominal Output Torque	[Nm]	*1	248	280	380	380	380	380	380	380
Maximum Acceleration Torque	[Nm]	*2	560	840	840	840	840	840	610	610
Maximum Torque	[Nm]	*3	630	1000	1000	950	950	950	730	730
Emergency Stop Torque	[Nm]	*4	1000	1250	1250	1250	1250	1250	1000	1000
Nominal Input Speed	[rpm]	*5	2100	2100	2100	2100	2600	2600	2600	2600
Maximum Input Speed	[rpm]	*6	5000	5000	5000	5000	5000	5000	5000	5000
No Load Running Torque	[Nm]	*7	1.63							
Maximum Radial Load	[N]	*8	9100							
Maximum Axial Load	[N]	*9	8200							
Moment of Inertia ($\leq \varnothing 14$)	[kgcm ²]	--	--	--	--	--	--	--	--	--
Moment of Inertia ($\leq \varnothing 19$)	[kgcm ²]	--	--	--	--	--	--	--	--	--
Moment of Inertia ($\leq \varnothing 28$)	[kgcm ²]	--	12	7.3	5.3	4.3	3.9	3.5	3.3	3.2
Moment of Inertia ($\leq \varnothing 38$)	[kgcm ²]	--	18	14	12	11	10	9.9	9.7	9.6
Moment of Inertia ($\leq \varnothing 48$)	[kgcm ²]	--	35	29	27	26	25	25	25	25
Efficiency	[%]	*10	95							
Torsional Rigidity	[Nm/arc-min]	*11	60							
Maximum Torsional Backlash	[arc-min]	--	≤ 3							
Noise Level	dB [A]	*12	≤ 67							
Protection Class	--	*13	IP54 (IP65)							
Ambient Temperature	[°C]	--	0-40							
Permitted Housing Temperature	[°C]	--	90							
Weight	[kg]	*14	16							

VRB 140 2-Stage Specifications

Frame Size	140									
Ratio	Unit	Note	15	16	20	25	28	30	35	40
Nominal Output Torque	[Nm]	*1	360	380	410	590	590	440	590	500
Maximum Acceleration Torque	[Nm]	*2	560	840	840	840	840	560	840	840
Maximum Torque	[Nm]	*3	560	840	840	840	840	560	840	840
Emergency Stop Torque	[Nm]	*4	1000	1250	1250	1250	1250	1000	1250	1250
Nominal Input Speed	[rpm]	*5	2900	2900	2900	2900	2900	2900	2900	2900
Maximum Input Speed	[rpm]	*6	6000	6000	6000	6000	6000	6000	6000	6000
No Load Running Torque	[Nm]	*7	0.56							
Maximum Radial Load	[N]	*8	9100							
Maximum Axial Load	[N]	*9	8200							
Moment of Inertia ($\leq \varnothing 14$)	[kgcm ²]	--	--	--	--	--	--	--	--	--
Moment of Inertia ($\leq \varnothing 19$)	[kgcm ²]	--	2.6	3.5	2.4	2.4	3.3	1.1	2.3	1.1
Moment of Inertia ($\leq \varnothing 28$)	[kgcm ²]	--	4.4	5.3	4.2	4.1	5.1	2.9	4.1	2.8
Moment of Inertia ($\leq \varnothing 38$)	[kgcm ²]	--	11	12	10	10	11	9.2	10	9.1
Moment of Inertia ($\leq \varnothing 48$)	[kgcm ²]	--	26	27	25	25	26	24	25	24
Efficiency	[%]	*10	90							
Torsional Rigidity	[Nm/arc-min]	*11	60							
Maximum Torsional Backlash	[arc-min]	--	≤ 3							
Noise Level	dB [A]	*12	≤ 67							
Protection Class	--	*13	IP54 (IP65)							
Ambient Temperature	[°C]	--	0-40							
Permitted Housing Temperature	[°C]	--	90							
Weight	[kg]	*14	17							

VRB 140 2-Stage Specifications

Frame Size	140										
Ratio	Unit	Note	45	50	60	70	80	90	100		
Nominal Output Torque	[Nm]	*1	440	590	590	590	590	440	440		
Maximum Acceleration Torque	[Nm]	*2	610	840	840	840	840	610	610		
Maximum Torque	[Nm]	*3	610	840	840	840	840	610	610		
Emergency Stop Torque	[Nm]	*4	1000	1250	1250	1250	1250	1000	1000		
Nominal Input Speed	[rpm]	*5	2900	3200	3200	3900	3900	3900	3900		
Maximum Input Speed	[rpm]	*6	6000	6000	6000	6000	6000	6000	6000		
No Load Running Torque	[Nm]	*7	0.56								
Maximum Radial Load	[N]	*8	9100								
Maximum Axial Load	[N]	*9	8200								
Moment of Inertia ($\leq \varnothing 14$)	[kgcm ²]	--	--	0.65	0.64	0.64	0.63	0.63	0.63		
Moment of Inertia ($\leq \varnothing 19$)	[kgcm ²]	--	2.3	1.1	1.1	1.1	1.1	1.1	1.1		
Moment of Inertia ($\leq \varnothing 28$)	[kgcm ²]	--	4.0	2.8	2.8	2.8	2.8	2.8	2.8		
Moment of Inertia ($\leq \varnothing 38$)	[kgcm ²]	--	10	9.1	9.1	9.1	9.1	9.1	9.1		
Moment of Inertia ($\leq \varnothing 48$)	[kgcm ²]	--	25	24	24	24	24	24	24		
Efficiency	[%]	*10	90								
Torsional Rigidity	[Nm/arc-min]	*11	60								
Maximum Torsional Backlash	[arc-min]	--	≤ 3								
Noise Level	dB [A]	*12	≤ 67								
Protection Class	--	*13	IP54 (IP65)								
Ambient Temperature	[°C]	--	0-40								
Permitted Housing Temperature	[°C]	--	90								
Weight	[kg]	*14	17								

*1 At nominal input speed, service life is 20,000 hours

*2 The maximum torque when starting or stopping operation. Apply Cycle Factor f_0 , found on page 468, for higher duty cycle applications

*3 Permitted 10,000 times during service life. Based on 10% of maximum radial load and smooth output shaft

*4 The maximum torque allowed under a stress situation. Permitted 1,000 times during service life

*5 The average input speed at nominal input torque. Maintain housing temperature below permitted value

*6 The maximum intermittent input speed

*7 Torque at no load applied to the input shaft at nominal input speed

*8 The maximum radial load that the gearbox can accept

*9 The maximum axial load that the gearbox can accept

*10 The efficiency at the nominal output torque rating

*11 This does not include lost motion

*12 Contact Nidec Drive Technology for the testing conditions and environment

*13 IP65 (wash-down) is available as an option. Contact Nidec Drive Technology for more details

*14 Weight may vary slightly between models

VRSF

PRE

PRF

VRL

VRB

VRS

VRT

PLANETARY Inline Gear Reducers

VRB 140 1-Stage Dimensions

Input bore size $\leq \phi 28$ mm

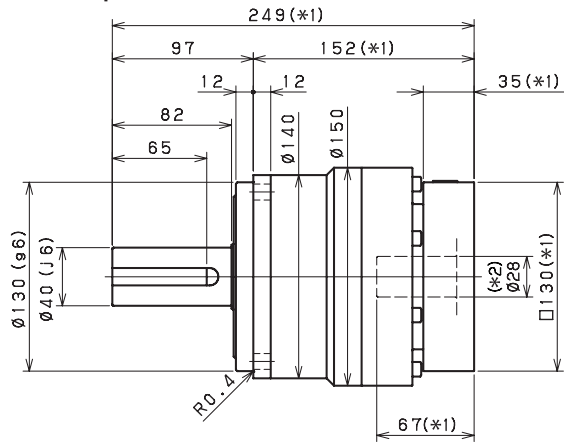
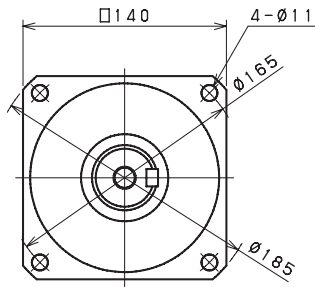

Input bore size $\leq \phi 38$ mm

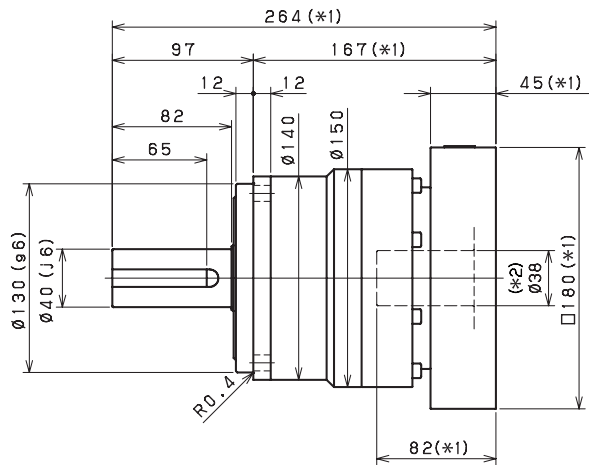
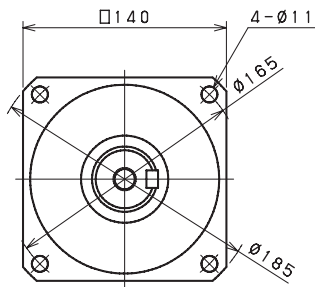

Input bore size $\leq \phi 48$ mm

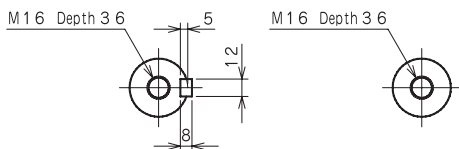
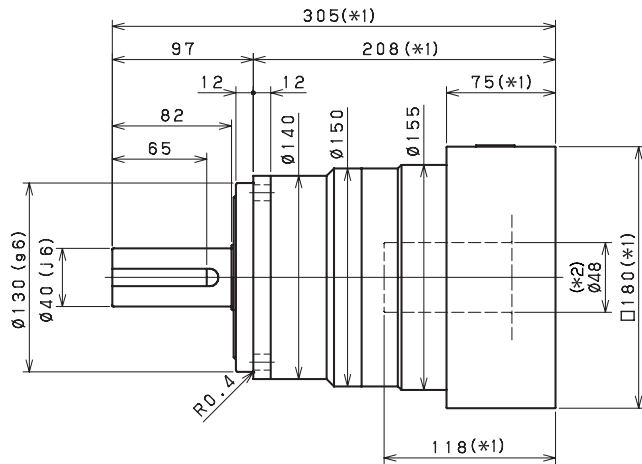
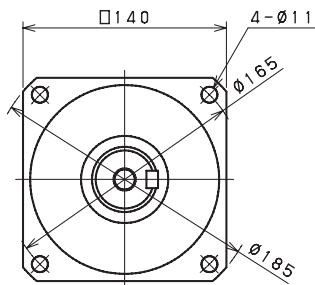

Keyed shaft

Smooth shaft

*1 Length will vary depending on motor

*2 Bushing will be inserted to adapt to motor shaft

VRB 140 2-Stage Dimensions

Input bore size $\leq \phi 19$ mm

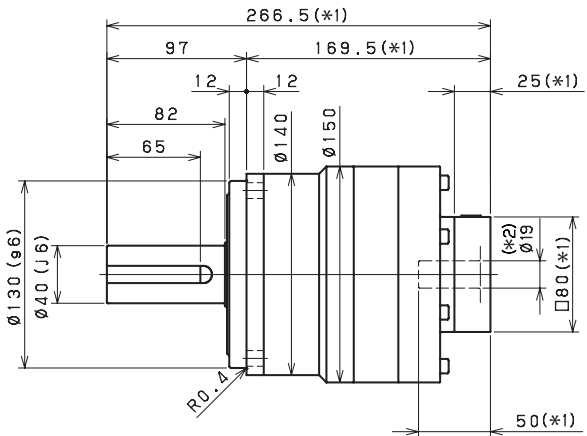
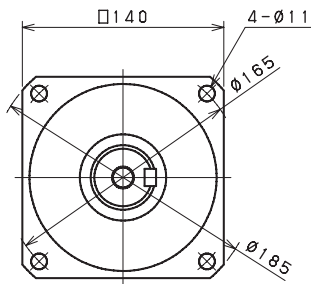

Input bore size $\leq \phi 28$ mm

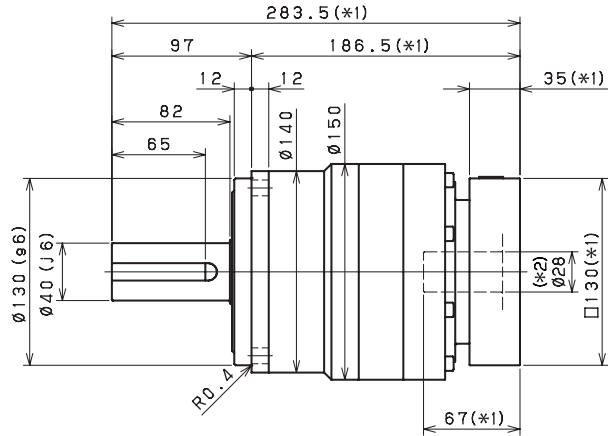
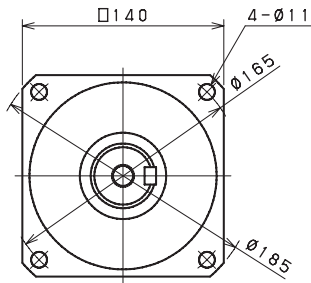

Input bore size $\leq \phi 38$ mm (*3)

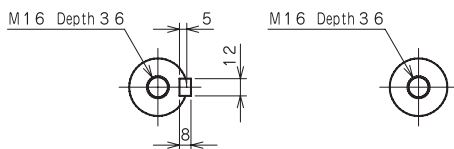
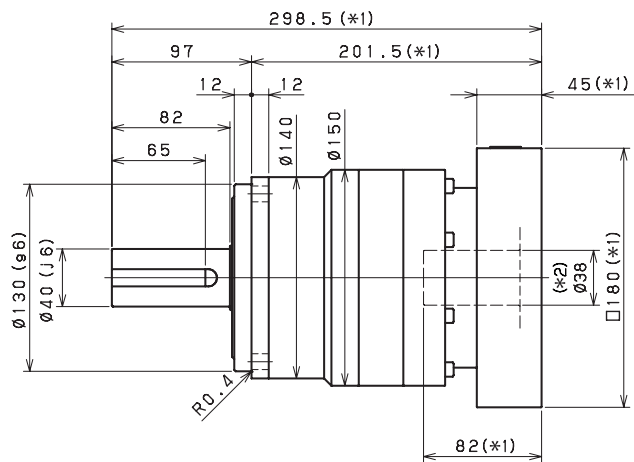
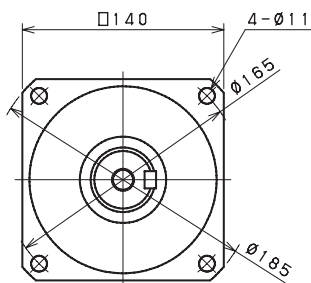

Keyed shaft

Smooth shaft

*1 Length will vary depending on motor

*2 Bushing will be inserted to adapt to motor shaft

*3 48mm input bore is available for this frame size. Use our online configurator to make your selection or contact us for assistance

VRSF

PRE

PRF

VRL

VRB

VR5

VRT

VRB 180 1-Stage Specifications

Frame Size	180									
Ratio	Unit	Note	3	4	5	6	7	8	9	10
Nominal Output Torque	[Nm]	*1	570	850	910	910	910	910	910	910
Maximum Acceleration Torque	[Nm]	*2	1300	1850	1850	1850	1850	1850	1350	1350
Maximum Torque	[Nm]	*3	1450	2250	2250	2150	2150	2150	1750	1750
Emergency Stop Torque	[Nm]	*4	2200	2750	2750	2750	2750	2750	2200	2200
Nominal Input Speed	[rpm]	*5	1500	1500	1500	1500	2300	2300	2300	2300
Maximum Input Speed	[rpm]	*6	4500	4500	4500	4500	4500	4500	4500	4500
No Load Running Torque	[Nm]	*7	2.68							
Maximum Radial Load	[N]	*8	15000							
Maximum Axial Load	[N]	*9	14000							
Moment of Inertia ($\leq \varnothing 19$)	[kgcm ²]	--	--	--	--	--	--	--	--	--
Moment of Inertia ($\leq \varnothing 28$)	[kgcm ²]	--	--	--	--	--	--	--	--	--
Moment of Inertia ($\leq \varnothing 38$)	[kgcm ²]	--	43	26	19	15	14	13	12	12
Moment of Inertia ($\leq \varnothing 48$)	[kgcm ²]	--	57	41	34	31	29	28	27	27
Moment of Inertia ($\leq \varnothing 65$)	[kgcm ²]	--	110	85	78	75	73	72	71	71
Efficiency	[%]	*10	95							
Torsional Rigidity	[Nm/arc-min]	*11	175							
Maximum Torsional Backlash	[arc-min]	--	≤ 3							
Noise Level	dB [A]	*12	≤ 67							
Protection Class	--	*13	IP54 (IP65)							
Ambient Temperature	[°C]	--	0-40							
Permitted Housing Temperature	[°C]	--	90							
Weight	[kg]	*14	36							

VRB 180 2-Stage Specifications

Frame Size	180									
Ratio	Unit	Note	15	16	20	25	28	30	35	40
Nominal Output Torque	[Nm]	*1	660	850	910	1100	1300	930	1300	1200
Maximum Acceleration Torque	[Nm]	*2	1300	1850	1850	1850	1850	1300	1850	1850
Maximum Torque	[Nm]	*3	1300	1850	1850	1850	1850	1300	1850	1850
Emergency Stop Torque	[Nm]	*4	2200	2750	2750	2750	2750	2200	2750	2750
Nominal Input Speed	[rpm]	*5	2700	2700	2700	2700	2700	2700	2700	2700
Maximum Input Speed	[rpm]	*6	5000	5000	5000	5000	5000	5000	5000	5000
No Load Running Torque	[Nm]	*7	1.39							
Maximum Radial Load	[N]	*8	15000							
Maximum Axial Load	[N]	*9	14000							
Moment of Inertia ($\leq \varnothing 19$)	[kgcm ²]	--	--	--	--	--	--	--	--	--
Moment of Inertia ($\leq \varnothing 28$)	[kgcm ²]	--	8.8	11	8.1	7.9	11	4.0	7.6	3.9
Moment of Inertia ($\leq \varnothing 38$)	[kgcm ²]	--	15	18	14	14	17	10	14	10
Moment of Inertia ($\leq \varnothing 48$)	[kgcm ²]	--	30	33	29	29	32	25	29	25
Moment of Inertia ($\leq \varnothing 65$)	[kgcm ²]	--	--	--	--	--	--	--	--	--
Efficiency	[%]	*10	90							
Torsional Rigidity	[Nm/arc-min]	*11	175							
Maximum Torsional Backlash	[arc-min]	--	≤ 3							
Noise Level	dB [A]	*12	≤ 67							
Protection Class	--	*13	IP54 (IP65)							
Ambient Temperature	[°C]	--	0-40							
Permitted Housing Temperature	[°C]	--	90							
Weight	[kg]	*14	37							

VRB 180 2-Stage Specifications

Frame Size	180										
Ratio	Unit	Note	45	50	60	70	80	90	100		
Nominal Output Torque	[Nm]	*1	930	1300	1300	1300	1300	930	930		
Maximum Acceleration Torque	[Nm]	*2	1350	1850	1850	1850	1850	1350	1350		
Maximum Torque	[Nm]	*3	1350	1850	1850	1850	1850	1350	1350		
Emergency Stop Torque	[Nm]	*4	2200	2750	2750	2750	2750	2200	2200		
Nominal Input Speed	[rpm]	*5	2700	2900	2900	3400	3400	3400	3400		
Maximum Input Speed	[rpm]	*6	5000	5000	5000	5000	5000	5000	5000		
No Load Running Torque	[Nm]	*7	1.39								
Maximum Radial Load	[N]	*8	15000								
Maximum Axial Load	[N]	*9	14000								
Moment of Inertia ($\leq \varnothing 19$)	[kgcm ²]	--	--	1.9	1.9	1.8	1.8	1.8	1.8		
Moment of Inertia ($\leq \varnothing 28$)	[kgcm ²]	--	7.6	3.8	3.8	3.8	3.7	3.7	3.7		
Moment of Inertia ($\leq \varnothing 38$)	[kgcm ²]	--	14	10	10	10	10	10	10		
Moment of Inertia ($\leq \varnothing 48$)	[kgcm ²]	--	29	25	25	25	25	25	25		
Moment of Inertia ($\leq \varnothing 65$)	[kgcm ²]	--	--	--	--	--	--	--	--		
Efficiency	[%]	*10	90								
Torsional Rigidity	[Nm/arc-min]	*11	175								
Maximum Torsional Backlash	[arc-min]	--	≤ 3								
Noise Level	dB [A]	*12	≤ 67								
Protection Class	--	*13	IP54 (IP65)								
Ambient Temperature	[°C]	--	0-40								
Permitted Housing Temperature	[°C]	--	90								
Weight	[kg]	*14	37								

- *1 At nominal input speed, service life is 20,000 hours
- *2 The maximum torque when starting or stopping operation. Apply Cycle Factor f_0 , found on page 468, for higher duty cycle applications
- *3 Permitted 10,000 times during service life. Based on 10% of maximum radial load and smooth output shaft
- *4 The maximum torque allowed under a stress situation. Permitted 1,000 times during service life
- *5 The average input speed at nominal input torque. Maintain housing temperature below permitted value
- *6 The maximum intermittent input speed
- *7 Torque at no load applied to the input shaft at nominal input speed
- *8 The maximum radial load that the gearbox can accept
- *9 The maximum axial load that the gearbox can accept
- *10 The efficiency at the nominal output torque rating
- *11 This does not include lost motion
- *12 Contact Nidec Drive Technology for the testing conditions and environment
- *13 IP65 (wash-down) is available as an option. Contact Nidec Drive Technology for more details
- *14 Weight may vary slightly between models

VRSF

PRE

PRF

VRL

VRB

VR5

VRT

VRB 220 1-Stage Specifications

Frame Size	220									
Ratio	Unit	Note	3	4	5	6	7	8	9	10
Nominal Output Torque	[Nm]	*1	980	1400	1400	1600	1700	1700	1700	1700
Maximum Acceleration Torque	[Nm]	*2	2000	2900	2900	2900	2900	2900	2600	2200
Maximum Torque	[Nm]	*3	2400	3700	3700	3500	3500	3400	3000	2700
Emergency Stop Torque	[Nm]	*4	4000	5000	5000	5000	5000	5000	4000	4000
Nominal Input Speed	[rpm]	*5	1200	1200	1500	1500	1700	1700	2000	2000
Maximum Input Speed	[rpm]	*6	3000	3000	3000	3000	3000	3000	3000	3000
No Load Running Torque	[Nm]	*7	2.92							
Maximum Radial Load	[N]	*8	15000							
Maximum Axial Load	[N]	*9	14000							
Moment of Inertia ($\leq \varnothing 28$)	[kgcm ²]	--	--	--	--	--	--	--	--	--
Moment of Inertia ($\leq \varnothing 38$)	[kgcm ²]	--	--	--	--	--	--	--	--	--
Moment of Inertia ($\leq \varnothing 48$)	[kgcm ²]	--	110	54	42	35	33	30	29	28
Moment of Inertia ($\leq \varnothing 65$)	[kgcm ²]	--	160	98	85	79	76	74	73	72
Efficiency	[%]	*10	95							
Torsional Rigidity	[Nm/arc-min]	*11	400							
Maximum Torsional Backlash	[arc-min]	--	≤ 3							
Noise Level	dB [A]	*12	≤ 61							
Protection Class	--	*13	IP54 (IP65)							
Ambient Temperature	[°C]	--	0-40							
Permitted Housing Temperature	[°C]	--	90							
Weight	[kg]	*14	53							

VRB 220 2-Stage Specifications

Frame Size	220									
Ratio	Unit	Note	15	16	20	25	28	30	35	40
Nominal Output Torque	[Nm]	*1	1100	1400	1500	1800	2000	1300	2000	2000
Maximum Acceleration Torque	[Nm]	*2	2000	2900	2900	2900	2900	2000	2900	2900
Maximum Torque	[Nm]	*3	2000	2900	2900	2900	2900	2000	2900	2900
Emergency Stop Torque	[Nm]	*4	4000	5000	5000	5000	5000	4000	5000	5000
Nominal Input Speed	[rpm]	*5	2200	2200	2200	2200	2200	2200	2200	2200
Maximum Input Speed	[rpm]	*6	4500	4500	4500	4500	4500	4500	4500	4500
No Load Running Torque	[Nm]	*7	1.14							
Maximum Radial Load	[N]	*8	15000							
Maximum Axial Load	[N]	*9	14000							
Moment of Inertia ($\leq \varnothing 28$)	[kgcm ²]	--	--	--	--	--	--	--	--	--
Moment of Inertia ($\leq \varnothing 38$)	[kgcm ²]	--	20	24	19	18	23	12	18	12
Moment of Inertia ($\leq \varnothing 48$)	[kgcm ²]	--	34	39	33	33	37	26	32	26
Moment of Inertia ($\leq \varnothing 65$)	[kgcm ²]	--	--	--	--	--	--	--	--	--
Efficiency	[%]	*10	90							
Torsional Rigidity	[Nm/arc-min]	*11	400							
Maximum Torsional Backlash	[arc-min]	--	≤ 3							
Noise Level	dB [A]	*12	≤ 61							
Protection Class	--	*13	IP54 (IP65)							
Ambient Temperature	[°C]	--	0-40							
Permitted Housing Temperature	[°C]	--	90							
Weight	[kg]	*14	54							

VRB 220 2-Stage Specifications

Frame Size	220										
Ratio	Unit	Note	45	50	60	70	80	90	100		
Nominal Output Torque	[Nm]	*1	1300	2000	2000	2000	2000	1300	1300		
Maximum Acceleration Torque	[Nm]	*2	1800	2900	2900	2900	2500	1800	1600		
Maximum Torque	[Nm]	*3	1800	2900	2900	2900	2500	1800	1600		
Emergency Stop Torque	[Nm]	*4	4000	5000	5000	5000	5000	4000	4000		
Nominal Input Speed	[rpm]	*5	2200	2500	2500	3000	3000	3000	3000		
Maximum Input Speed	[rpm]	*6	4500	4500	4500	4500	4500	4500	4500		
No Load Running Torque	[Nm]	*7	1.14								
Maximum Radial Load	[N]	*8	15000								
Maximum Axial Load	[N]	*9	14000								
Moment of Inertia ($\leq \varnothing 28$)	[kgcm ²]	--	--	4.7	4.7	4.6	4.6	4.6	4.6		
Moment of Inertia ($\leq \varnothing 38$)	[kgcm ²]	--	18	12	11	11	11	11	11		
Moment of Inertia ($\leq \varnothing 48$)	[kgcm ²]	--	32	26	26	26	26	26	26		
Moment of Inertia ($\leq \varnothing 65$)	[kgcm ²]	--	--	--	--	--	--	--	--		
Efficiency	[%]	*10	90								
Torsional Rigidity	[Nm/arc-min]	*11	400								
Maximum Torsional Backlash	[arc-min]	--	≤ 3								
Noise Level	dB [A]	*12	≤ 61								
Protection Class	--	*13	IP54 (IP65)								
Ambient Temperature	[°C]	--	0-40								
Permitted Housing Temperature	[°C]	--	90								
Weight	[kg]	*14	54								

- *1 At nominal input speed, service life is 20,000 hours
- *2 The maximum torque when starting or stopping operation. Apply Cycle Factor f_0 , found on page 468, for higher duty cycle applications
- *3 Permitted 10,000 times during service life. Based on 10% of maximum radial load and smooth output shaft
- *4 The maximum torque allowed under a stress situation. Permitted 1,000 times during service life
- *5 The average input speed at nominal input torque. Maintain housing temperature below permitted value
- *6 The maximum intermittent input speed
- *7 Torque at no load applied to the input shaft at nominal input speed
- *8 The maximum radial load that the gearbox can accept
- *9 The maximum axial load that the gearbox can accept
- *10 The efficiency at the nominal output torque rating
- *11 This does not include lost motion
- *12 Contact Nidec Drive Technology for the testing conditions and environment
- *13 IP65 (wash-down) is available as an option. Contact Nidec Drive Technology for more details
- *14 Weight may vary slightly between models

VRSF

PRE

PRF

VR

VRB

VR

VRT

PLANETARY Inline Gear Reducers

VRB 220 1-Stage Dimensions

Input bore size $\leq \varnothing 48$ mm

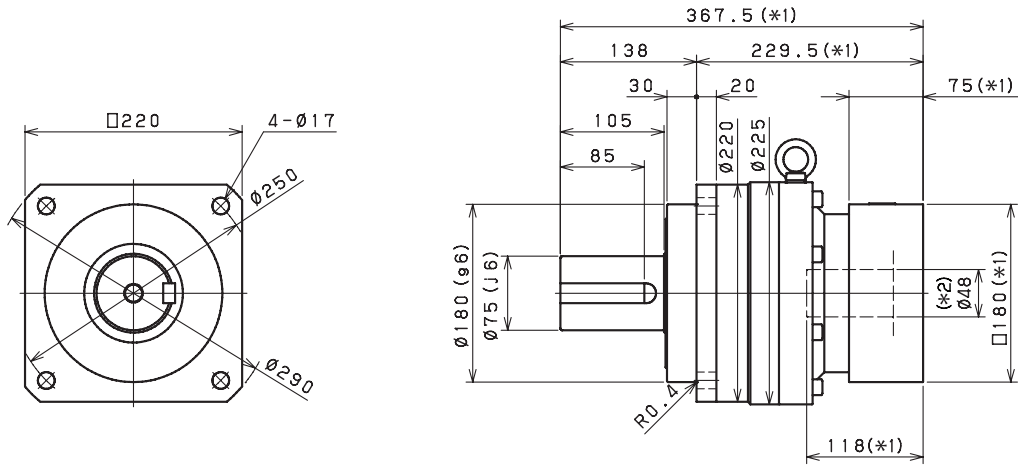

Input bore size $\leq \varnothing 65$ mm

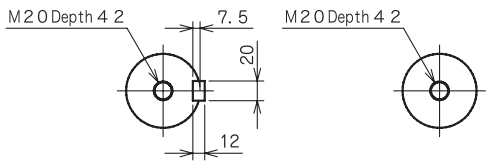
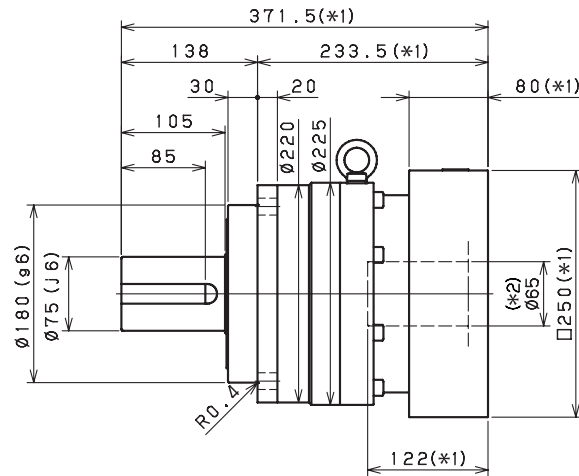

Keyed shaft

Smooth shaft

*1 Length will vary depending on motor

*2 Bushing will be inserted to adapt to motor shaft

VRB 220 2-Stage Dimensions

Input bore size $\leq \varnothing 38$ mm

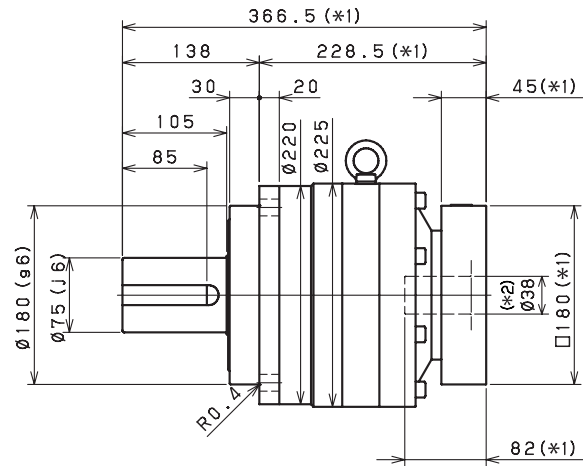
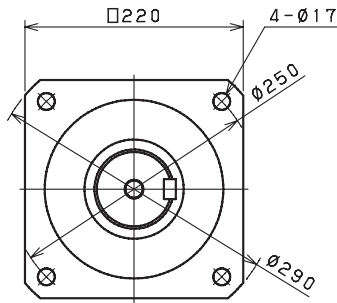

Input bore size $\leq \varnothing 48$ mm

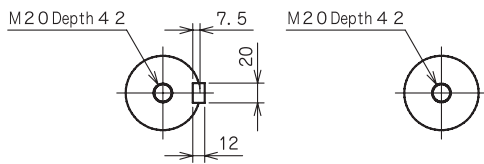
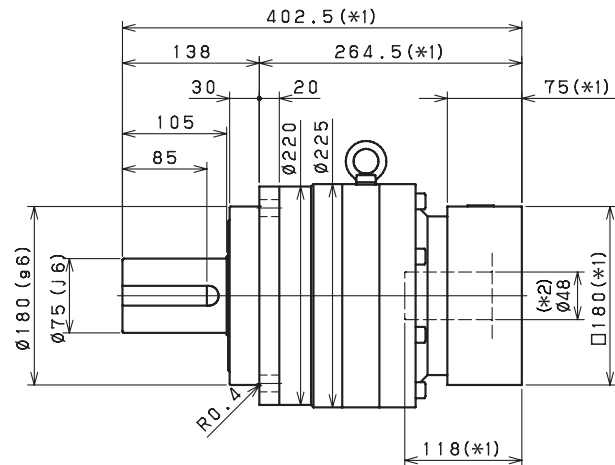
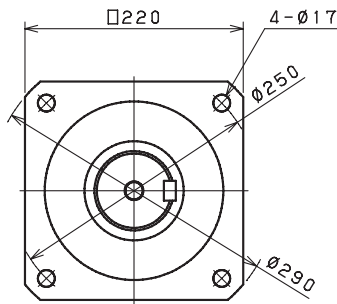

Keyed shaft

Smooth shaft

*1 Length will vary depending on motor

*2 Bushing will be inserted to adapt to motor shaft

VRSF

PRE

PRF

VRB

VRB

VRS

VRT