

VRB 115 1-Stage Specifications

Frame Size	115									
Ratio	Unit	Note	3	4	5	6	7	8	9	10
Nominal Output Torque	[Nm]	*1	128	146	190	190	190	190	190	190
Maximum Acceleration Torque	[Nm]	*2	270	390	390	390	390	390	292	292
Maximum Torque (new)	--	*3	340	490	490	480	480	480	370	370
Emergency Stop Torque	[Nm]	*4	500	625	625	625	625	625	500	500
Nominal Input Speed	[rpm]	*5	2800	2800	2800	2800	2800	2800	2800	2800
Maximum Input Speed	[rpm]	*6	5500	5500	5500	5500	5500	5500	5500	5500
No Load Running Torque	[Nm]	*7	1.30							
Maximum Radial Load	[N]	*8	4300							
Maximum Axial Load	[N]	*9	3900							
Moment of Inertia ($\leq \varnothing 8$)	[kgcm ²]	--	--	--	--	--	--	--	--	--
Moment of Inertia ($\leq \varnothing 14$)	[kgcm ²]	--	--	--	--	--	--	--	--	--
Moment of Inertia ($\leq \varnothing 19$)	[kgcm ²]	--	3.2	2.0	1.4	1.2	1.0	0.92	0.86	0.83
Moment of Inertia ($\leq \varnothing 28$)	[kgcm ²]	--	5.1	3.7	3.1	2.9	2.8	2.7	2.6	2.6
Moment of Inertia ($\leq \varnothing 38$)	[kgcm ²]	--	12	10	9.5	9.3	9.1	9.0	8.9	8.9
Efficiency	[%]	*10	95							
Torsional Rigidity	[Nm/arc-min]	*11	31							
Maximum Torsional Backlash	[arc-min]	--	≤ 3							
Noise Level	dB [A]	*12	≤ 71							
Protection Class	--	*13	IP54 (IP65)							
Ambient Temperature	[°C]	--	0-40							
Permitted Housing Temperature	[°C]	--	90							
Weight	[kg]	*14	8							

VRB 115 2-Stage Specifications

Frame Size	115									
Ratio	Unit	Note	15	16	20	25	28	30	35	40
Nominal Output Torque	[Nm]	*1	174	200	220	280	280	220	280	270
Maximum Acceleration Torque	[Nm]	*2	270	390	390	390	390	270	390	390
Maximum Torque (new)	--	*3	270	390	390	390	390	270	390	390
Emergency Stop Torque	[Nm]	*4	500	625	625	625	625	500	625	625
Nominal Input Speed	[rpm]	*5	3100	3100	3100	3100	3100	3100	3100	3100
Maximum Input Speed	[rpm]	*6	6500	6500	6500	6500	6500	6500	6500	6500
No Load Running Torque	[Nm]	*7	0.42							
Maximum Radial Load	[N]	*8	4300							
Maximum Axial Load	[N]	*9	3900							
Moment of Inertia ($\leq \varnothing 8$)	[kgcm ²]	--	--	--	--	--	--	--	--	--
Moment of Inertia ($\leq \varnothing 14$)	[kgcm ²]	--	0.77	0.98	0.72	0.70	0.92	0.38	0.68	0.37
Moment of Inertia ($\leq \varnothing 19$)	[kgcm ²]	--	1.2	1.4	1.1	1.1	1.3	0.78	1.1	0.77
Moment of Inertia ($\leq \varnothing 28$)	[kgcm ²]	--	2.9	3.1	2.8	2.8	3.0	2.5	2.8	2.5
Moment of Inertia ($\leq \varnothing 38$)	[kgcm ²]	--	9.2	9.4	9.1	9.1	9.3	8.8	9.1	8.8
Efficiency	[%]	*10	90							
Torsional Rigidity	[Nm/arc-min]	*11	31							
Maximum Torsional Backlash	[arc-min]	--	≤ 3							
Noise Level	dB [A]	*12	≤ 71							
Protection Class	--	*13	IP54 (IP65)							
Ambient Temperature	[°C]	--	0-40							
Permitted Housing Temperature	[°C]	--	90							
Weight	[kg]	*14	8.9							

VRB 115 2-Stage Specifications

Frame Size	115										
Ratio	Unit	Note	45	50	60	70	80	90	100		
Nominal Output Torque	[Nm]	*1	220	280	280	280	280	220	220		
Maximum Acceleration Torque	[Nm]	*2	292	390	390	390	390	292	292		
Maximum Torque (new)	--	*3	292	390	390	390	390	292	292		
Emergency Stop Torque	[Nm]	*4	500	625	625	625	625	500	500		
Nominal Input Speed	[rpm]	*5	3100	3500	3500	4200	4200	4200	4200		
Maximum Input Speed	[rpm]	*6	6500	6500	6500	6500	6500	6500	6500		
No Load Running Torque	[Nm]	*7	0.42								
Maximum Radial Load	[N]	*8	4300								
Maximum Axial Load	[N]	*9	3900								
Moment of Inertia ($\leq \varnothing 8$)	[kgcm ²]	--	--	0.19	0.19	0.19	0.19	0.19	0.19		
Moment of Inertia ($\leq \varnothing 14$)	[kgcm ²]	--	0.68	0.36	0.36	0.36	0.36	0.36	0.36		
Moment of Inertia ($\leq \varnothing 19$)	[kgcm ²]	--	1.1	0.76	0.76	0.76	0.76	0.76	0.76		
Moment of Inertia ($\leq \varnothing 28$)	[kgcm ²]	--	2.8	2.5	2.5	2.5	2.5	2.5	2.5		
Moment of Inertia ($\leq \varnothing 38$)	[kgcm ²]	--	9.1	8.8	8.8	8.8	8.8	8.8	8.8		
Efficiency	[%]	*10	90								
Torsional Rigidity	[Nm/arc-min]	*11	31								
Maximum Torsional Backlash	[arc-min]	--	≤ 3								
Noise Level	dB [A]	*12	≤ 71								
Protection Class	--	*13	IP54 (IP65)								
Ambient Temperature	[°C]	--	0-40								
Permitted Housing Temperature	[°C]	--	90								
Weight	[kg]	*14	8.9								

*1 At nominal input speed, service life is 20,000 hours

*2 The maximum torque when starting or stopping operation. Apply Cycle Factor f_0 , found on page 468, for higher duty cycle applications

*3 Permitted 10,000 times during service life. Based on 10% of maximum radial load and smooth output shaft

*4 The maximum torque allowed under a stress situation. Permitted 1,000 times during service life

*5 The average input speed at nominal input torque. Maintain housing temperature below permitted value

*6 The maximum intermittent input speed

*7 Torque at no load applied to the input shaft at nominal input speed

*8 The maximum radial load that the gearbox can accept

*9 The maximum axial load that the gearbox can accept

*10 The efficiency at the nominal output torque rating

*11 This does not include lost motion

*12 Contact Nidec Drive Technology for the testing conditions and environment

*13 IP65 (wash-down) is available as an option. Contact Nidec Drive Technology for more details

*14 Weight may vary slightly between models

VRSF

PRE

PRF

VRL

VRB

VRS

VRT

PLANETARY Inline Gear Reducers

VRB 115 1-Stage Dimensions

Input bore size $\leq \phi 19$ mm

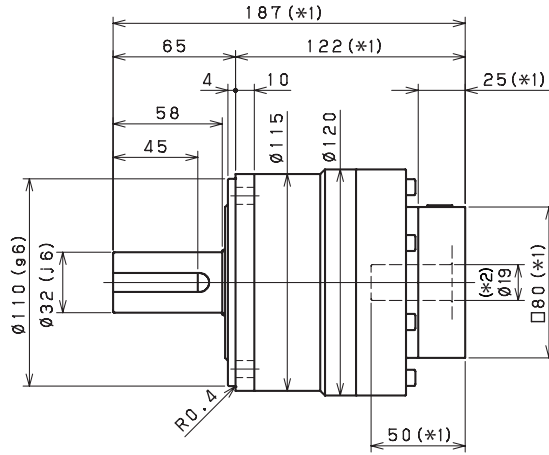
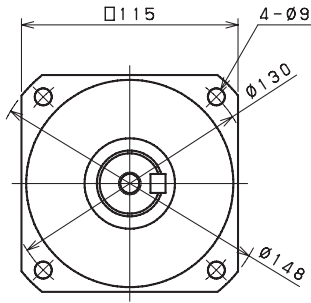

Input bore size $\leq \phi 28$ mm

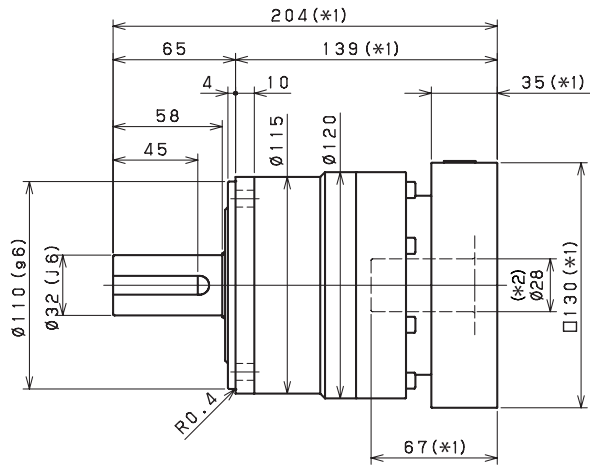
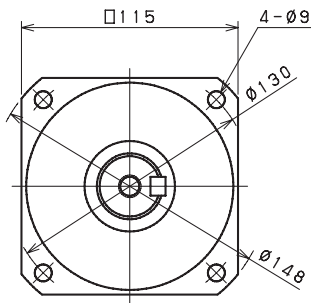

Input bore size $\leq \phi 38$ mm

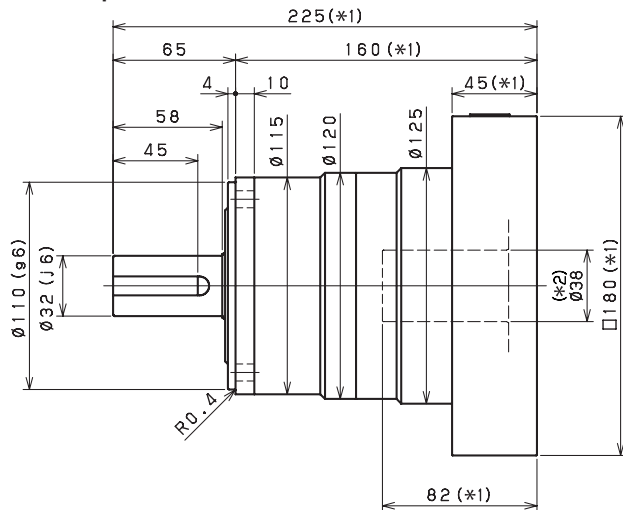
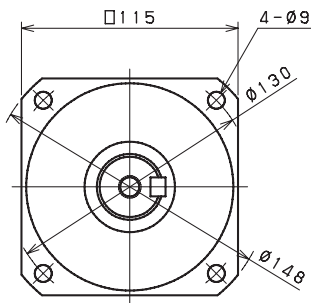

M12 Depth 2.8

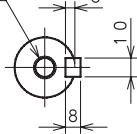

Keyed shaft

M12 Depth 2.8



Smooth shaft

*1 Length will vary depending on motor

*2 Bushing will be inserted to adapt to motor shaft

VRB 115 2-Stage Dimensions

Input bore size $\leq \phi 14$ mm

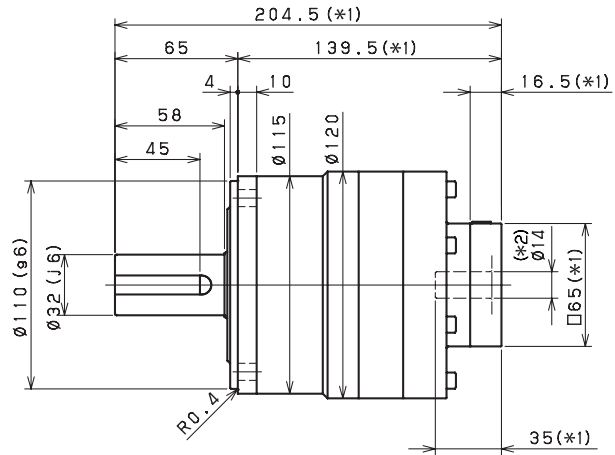
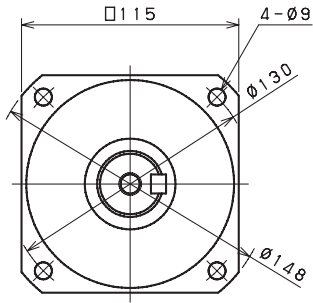

Input bore size $\leq \phi 19$ mm

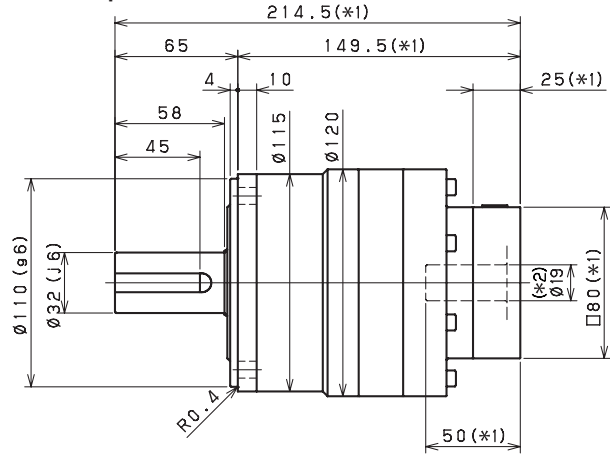
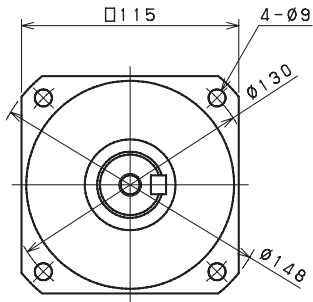

Input bore size $\leq \phi 28$ mm (*3)

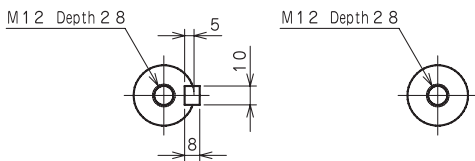
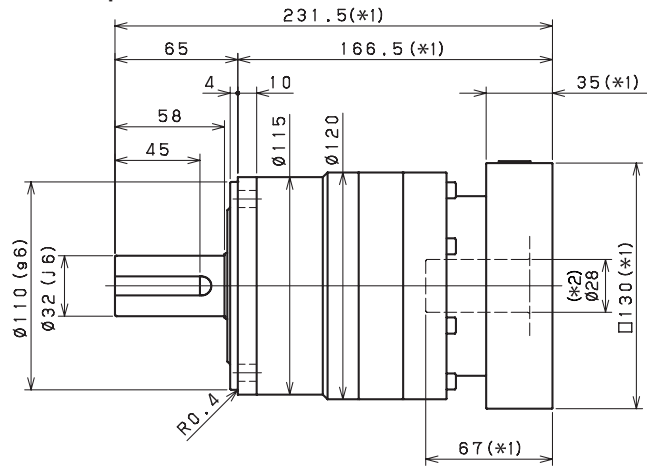
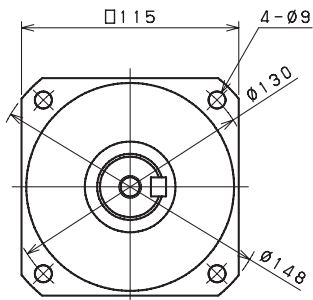

Keyed shaft

Smooth shaft

*1 Length will vary depending on motor

*2 Bushing will be inserted to adapt to motor shaft

*3 38mm input bore is available for this frame size. Use our online configurator to make your selection or contact us for assistance

VRSF

PRE

PRF

VRL

VRB

VR5

VRT