

VRB 060 1-Stage Specifications

Frame Size	060									
Ratio	Unit	Note	3	4	5	6	7	8	9	10
Nominal Output Torque	[Nm]	*1	19	27	28	28	28	28	28	28
Maximum Acceleration Torque	[Nm]	*2	46	66	66	66	66	66	46	46
Maximum Torque	[Nm]	*3	55	79	79	79	79	76	55	55
Emergency Stop Torque	[Nm]	*4	80	100	100	100	100	100	80	80
Nominal Input Speed	[rpm]	*5	3300	3300	4000	4000	4000	4000	4000	4000
Maximum Input Speed	[rpm]	*6	7500	7500	7500	7500	7500	7500	7500	7500
No Load Running Torque	[Nm]	*7	0.15							
Maximum Radial Load	[N]	*8	1200							
Maximum Axial Load	[N]	*9	1100							
Moment of Inertia ($\leq \varnothing 8$)	[kgcm ²]	--	0.14	0.095	0.077	0.068	0.062	0.059	0.057	0.056
Moment of Inertia ($\leq \varnothing 14$)	[kgcm ²]	--	0.25	0.21	0.19	0.18	0.17	0.17	0.17	0.17
Moment of Inertia ($\leq \varnothing 19$)	[kgcm ²]	--	0.53	0.48	0.46	0.46	0.45	0.45	0.44	0.44
Efficiency	[%]	*10	95							
Torsional Rigidity	[Nm/arc-min]	*11	3							
Maximum Torsional Backlash	[arc-min]	--	≤ 3							
Noise Level	dB [A]	*12	≤ 66							
Protection Class	--	*13	IP54 (IP65)							
Ambient Temperature	[°C]	--	0-40							
Permitted Housing Temperature	[°C]	--	90							
Weight	[kg]	*14	1.4							

VRB 060 2-Stage Specifications

Frame Size	060									
Ratio	Unit	Note	15	16	20	25	28	30	35	40
Nominal Output Torque	[Nm]	*1	25	32	32	43	45	32	45	45
Maximum Acceleration Torque	[Nm]	*2	46	66	66	66	66	46	66	66
Maximum Torque	[Nm]	*3	46	66	66	66	66	46	66	66
Emergency Stop Torque	[Nm]	*4	80	100	100	100	100	80	100	100
Nominal Input Speed	[rpm]	*5	4000	4000	4000	4000	4000	4000	4000	4000
Maximum Input Speed	[rpm]	*6	8500	8500	8500	8500	8500	8500	8500	8500
No Load Running Torque	[Nm]	*7	0.04							
Maximum Radial Load	[N]	*8	1200							
Maximum Axial Load	[N]	*9	1100							
Moment of Inertia ($\leq \varnothing 8$)	[kgcm ²]	--	0.064	0.070	0.062	0.061	0.068	0.051	0.061	0.051
Moment of Inertia ($\leq \varnothing 14$)	[kgcm ²]	--	0.18	0.18	0.17	0.17	0.18	0.16	0.17	0.16
Moment of Inertia ($\leq \varnothing 19$)	[kgcm ²]	--	0.45	0.46	0.45	0.45	0.46	0.44	0.45	0.44
Efficiency	[%]	*10	90							
Torsional Rigidity	[Nm/arc-min]	*11	3							
Maximum Torsional Backlash	[arc-min]	--	≤ 3							
Noise Level	dB [A]	*12	≤ 66							
Protection Class	--	*13	IP54 (IP65)							
Ambient Temperature	[°C]	--	0-40							
Permitted Housing Temperature	[°C]	--	90							
Weight	[kg]	*14	1.6							

VRB 060 2-Stage Specifications

Frame Size	060										
Ratio	Unit	Note	45	50	60	70	80	90	100		
Nominal Output Torque	[Nm]	*1	32	45	45	45	45	32	32		
Maximum Acceleration Torque	[Nm]	*2	46	66	66	66	66	46	46		
Maximum Torque	[Nm]	*3	46	66	66	66	66	46	46		
Emergency Stop Torque	[Nm]	*4	80	100	100	100	100	80	80		
Nominal Input Speed	[rpm]	*5	4000	4800	4800	5500	5500	5500	5500		
Maximum Input Speed	[rpm]	*6	8500	8500	8500	8500	8500	8500	8500		
No Load Running Torque	[Nm]	*7	0.04								
Maximum Radial Load	[N]	*8	1200								
Maximum Axial Load	[N]	*9	1100								
Moment of Inertia ($\leq \varnothing 8$)	[kgcm ²]	--	0.061	0.051	0.051	0.051	0.051	0.051	0.051		
Moment of Inertia ($\leq \varnothing 14$)	[kgcm ²]	--	0.17	0.16	0.16	0.16	0.16	0.16	0.16		
Moment of Inertia ($\leq \varnothing 19$)	[kgcm ²]	--	0.45	0.44	0.44	0.44	0.44	0.44	0.44		
Efficiency	[%]	*10	90								
Torsional Rigidity	[Nm/arc-min]	*11	3								
Maximum Torsional Backlash	[arc-min]	--	≤ 3								
Noise Level	dB [A]	*12	≤ 66								
Protection Class	--	*13	IP54 (IP65)								
Ambient Temperature	[°C]	--	0-40								
Permitted Housing Temperature	[°C]	--	90								
Weight	[kg]	*14	1.6								

*1 At nominal input speed, service life is 20,000 hours

*2 The maximum torque when starting or stopping operation. Apply Cycle Factor f_0 , found on page 468, for higher duty cycle applications

*3 Permitted 10,000 times during service life. Based on 10% of maximum radial load and smooth output shaft

*4 The maximum torque allowed under a stress situation. Permitted 1,000 times during service life

*5 The average input speed at nominal input torque. Maintain housing temperature below permitted value

*6 The maximum intermittent input speed

*7 Torque at no load applied to the input shaft at nominal input speed

*8 The maximum radial load that the gearbox can accept

*9 The maximum axial load that the gearbox can accept

*10 The efficiency at the nominal output torque rating

*11 This does not include lost motion

*12 Contact Nidec Drive Technology for the testing conditions and environment

*13 IP65 (wash-down) is available as an option. Contact Nidec Drive Technology for more details

*14 Weight may vary slightly between models

VRSF

PRE

PRF

VRL

VRB

VR5

VRT

PLANETARY Inline Gear Reducers

VRB 060 1-Stage Dimensions

Input bore size $\leq \varnothing 8$ mm

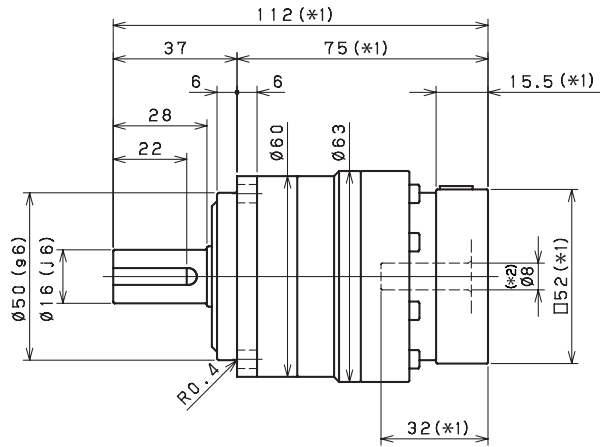
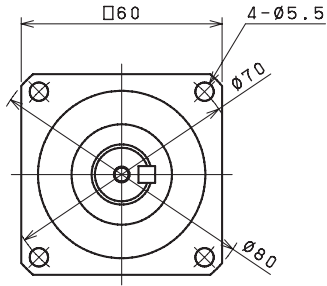

Input bore size $\leq \varnothing 14$ mm

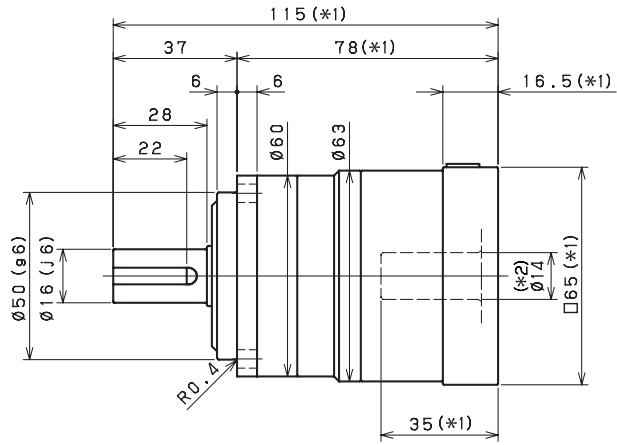
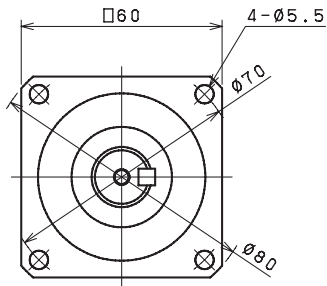

Input bore size $\leq \varnothing 19$ mm

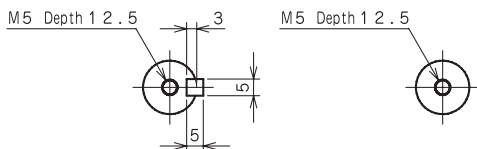
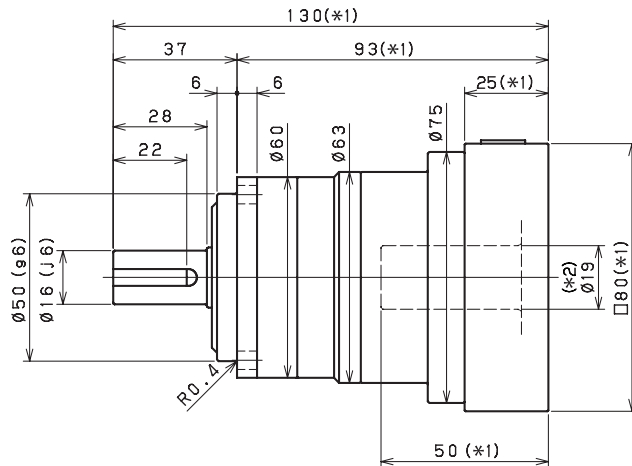
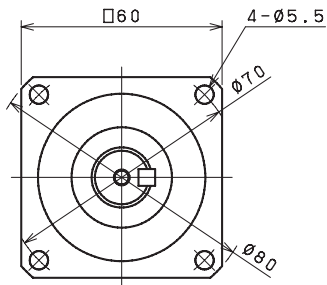

Keyed shaft

Smooth shaft

*1 Length will vary depending on motor

*2 Bushing will be inserted to adapt to motor shaft

VRB 060 2-Stage Dimensions

Input bore size $\leq \phi 8$ mm

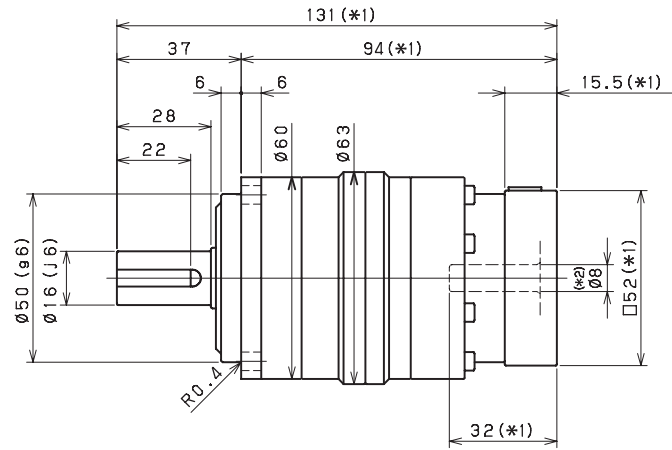
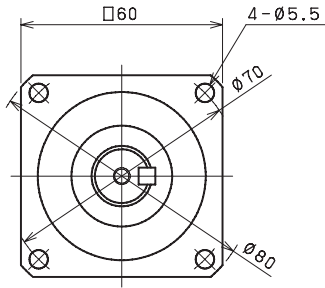

Input bore size $\leq \phi 14$ mm

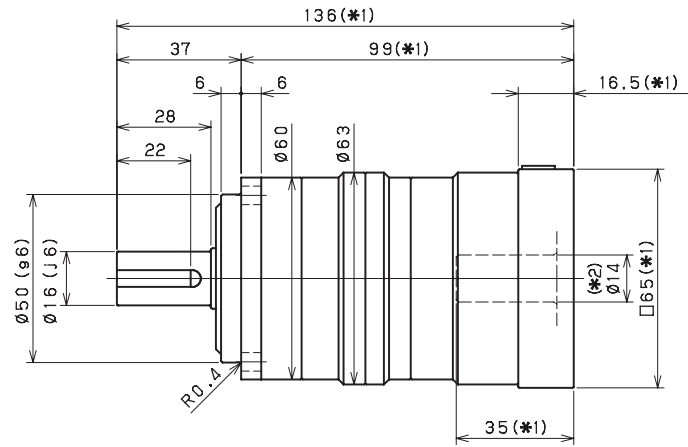
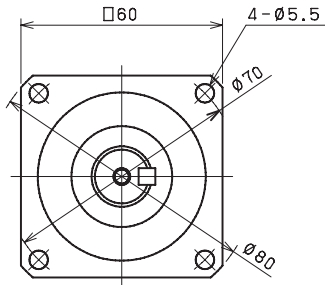

Input bore size $\leq \phi 19$ mm

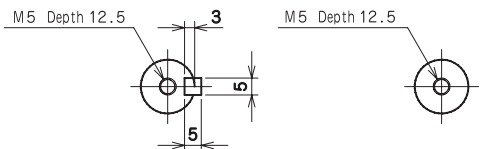
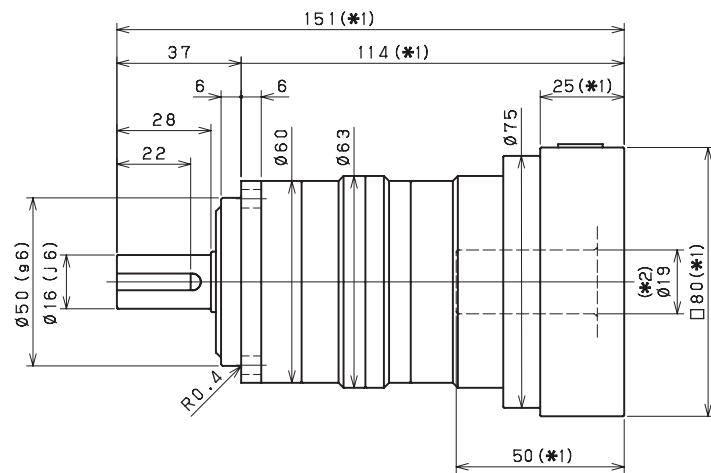
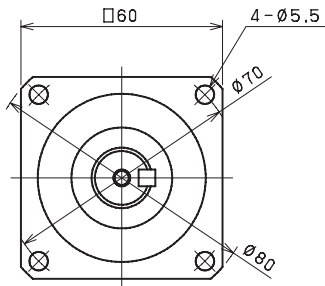

Keyed shaft

Smooth shaft

*1 Length will vary depending on motor

*2 Bushing will be inserted to adapt to motor shaft

VRSF

PRE

PRF

VRL

VRB

VR5

VRT