

## VRB 042 1-Stage Specifications

Frame Size	042									
Ratio	Units	Notes	3	4	5	6	7	8	9	10
Nominal Output Torque	[Nm]	*1	6	9	10	10	10	10	10	10
Maximum Acceleration Torque	[Nm]	*2	14	21	21	21	21	21	14	14
Maximum Torque	[Nm]	*3	17	25	25	25	25	25	17	17
Emergency Stop Torque	[Nm]	*4	30	35	35	35	35	35	30	30
Nominal Input Speed	[rpm]	*5	4000	4000	4000	4000	4000	4000	4000	4000
Maximum Input Speed	[rpm]	*6	8000	8000	8000	8000	8000	8000	8000	8000
No Load Running Torque	[Nm]	*7	0.03							
Maximum Radial Load	[N]	*8	710							
Maximum Axial Load	[N]	*9	640							
Moment of Inertia ( $\leq \varnothing 8$ )	[kgcm <sup>2</sup> ]	--	0.053	0.041	0.036	0.034	0.032	0.031	0.031	0.030
Moment of Inertia ( $\leq \varnothing 14$ )	[kgcm <sup>2</sup> ]	--	0.17	0.16	0.15	0.15	0.15	0.15	0.15	0.15
Efficiency	[%]	*10	95							
Torsional Rigidity	[Nm/arc-min]	*11	2							
Maximum Torsional Backlash	[arc-min]	--	$\leq 3$							
Noise Level	dB [A]	*12	$\leq 61$							
Protection Class	--	*13	IP54 (IP65)							
Ambient Temperature	[°C]	--	0-40							
Permitted Housing Temperature	[°C]	--	90							
Weight	[kg]	*14	0.6							

## VRB 042 2-Stage Specifications

Frame Size	042									
Ratio	Units	Notes	15	16	20	25	28	30	35	40
Nominal Output Torque	[Nm]	*1	9	14	14	15	15	11	15	15
Maximum Acceleration Torque	[Nm]	*2	14	21	21	21	21	14	21	21
Maximum Torque	[Nm]	*3	14	21	21	21	21	14	21	21
Emergency Stop Torque	[Nm]	*4	30	35	35	35	35	30	35	35
Nominal Input Speed	[rpm]	*5	4000	4000	4000	4000	4000	4000	4000	4000
Maximum Input Speed	[rpm]	*6	8500	8500	8500	8500	8500	8500	8500	8500
No Load Running Torque	[Nm]	*7	0.01							
Maximum Radial Load	[N]	*8	710							
Maximum Axial Load	[N]	*9	640							
Moment of Inertia ( $\leq \varnothing 8$ )	[kgcm <sup>2</sup> ]	--	0.035	0.038	0.034	0.034	0.038	0.030	0.034	0.030
Moment of Inertia ( $\leq \varnothing 14$ )	[kgcm <sup>2</sup> ]	--	--	--	--	--	--	--	--	--
Efficiency	[%]	*10	90							
Torsional Rigidity	[Nm/arc-min]	*11	2							
Maximum Torsional Backlash	[arc-min]	--	$\leq 5$							
Noise Level	dB [A]	*12	$\leq 61$							
Protection Class	--	*13	IP54 (IP65)							
Ambient Temperature	[°C]	--	0-40							
Permitted Housing Temperature	[°C]	--	90							
Weight	[kg]	*14	0.7							

## VRB 042 2-Stage Specifications

Frame Size	042										
Ratio	Units	Notes	45	50	60	70	80	90	100		
Nominal Output Torque	[Nm]	*1	11	15	15	15	15	11	11		
Maximum Acceleration Torque	[Nm]	*2	14	21	21	21	21	14	14		
Maximum Torque	[Nm]	*3	14	21	21	21	21	14	14		
Emergency Stop Torque	[Nm]	*4	30	35	35	35	35	30	30		
Nominal Input Speed	[rpm]	*5	4000	4000	4000	4000	4000	4000	4000		
Maximum Input Speed	[rpm]	*6	8500	8500	8500	8500	8500	8500	8500		
No Load Running Torque	[Nm]	*7	0.01								
Maximum Radial Load	[N]	*8	710								
Maximum Axial Load	[N]	*9	640								
Moment of Inertia ( $\leq \varnothing 8$ )	[kgcm <sup>2</sup> ]	--	0.034	0.030	0.030	0.030	0.030	0.030	0.030		
Moment of Inertia ( $\leq \varnothing 14$ )	[kgcm <sup>2</sup> ]	--	--	--	--	--	--	--	--		
Efficiency	[%]	*10	90								
Torsional Rigidity	[Nm/arc-min]	*11	2								
Maximum Torsional Backlash	[arc-min]	--	$\leq 5$								
Noise Level	dB [A]	*12	$\leq 61$								
Protection Class	--	*13	IP54 (IP65)								
Ambient Temperature	[°C]	--	0-40								
Permitted Housing Temperature	[°C]	--	90								
Weight	[kg]	*14	0.7								

\*1 At nominal input speed, service life is 20,000 hours

\*2 The maximum torque when starting or stopping operation. Apply Cycle Factor  $f_0$ , found on page 468, for higher duty cycle applications

\*3 Permitted 10,000 times during service life. Based on 10% of maximum radial load and smooth output shaft

\*4 The maximum torque allowed under a stress situation. Permitted 1,000 times during service life

\*5 The average input speed at nominal input torque. Maintain housing temperature below permitted value

\*6 The maximum intermittent input speed

\*7 Torque at no load applied to the input shaft at nominal input speed

\*8 The maximum radial load that the gearbox can accept

\*9 The maximum axial load that the gearbox can accept

\*10 The efficiency at the nominal output torque rating

\*11 This does not include lost motion

\*12 Contact Nidec Drive Technology for the testing conditions and environment

\*13 IP65 (wash-down) is available as an option. Contact Nidec Drive Technology for more details

\*14 Weight may vary slightly between models

VRSF

PRE

PRF

VRL

VRB

VR5

VRT

# PLANETARY Inline Gear Reducers

## VRB 042 1-Stage Dimensions

Input bore size  $\leq \phi 8$  mm

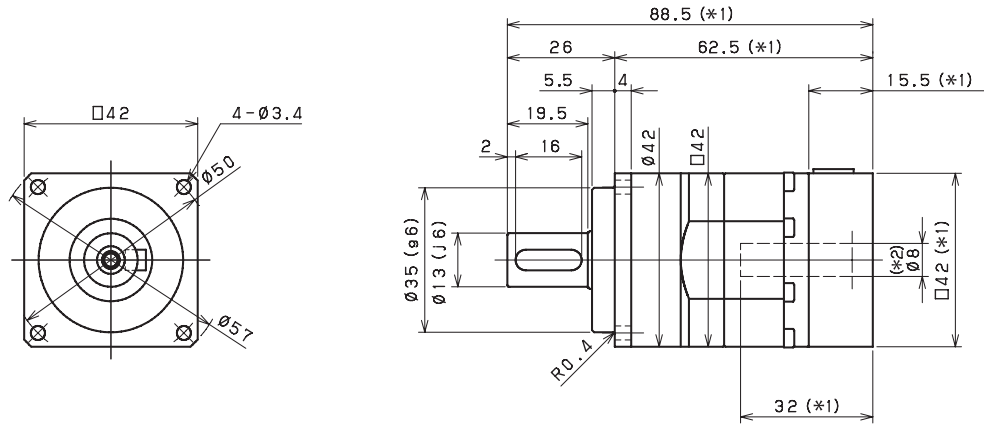

Input bore size  $\leq \phi 14$  mm

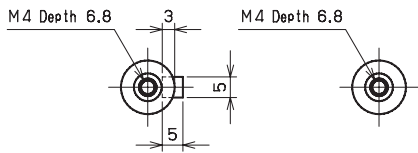
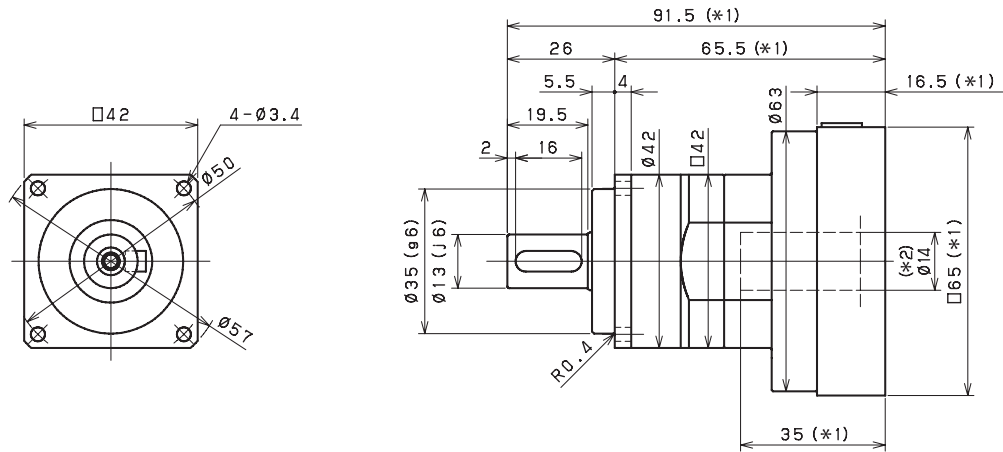

Keyed shaft

Smooth shaft

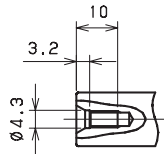

\*1 Length will vary depending on motor

\*2 Bushing will be inserted to adapt to motor shaft

## VRB 042 2-Stage Dimensions

Input bore size  $\leq \varnothing 8$  mm

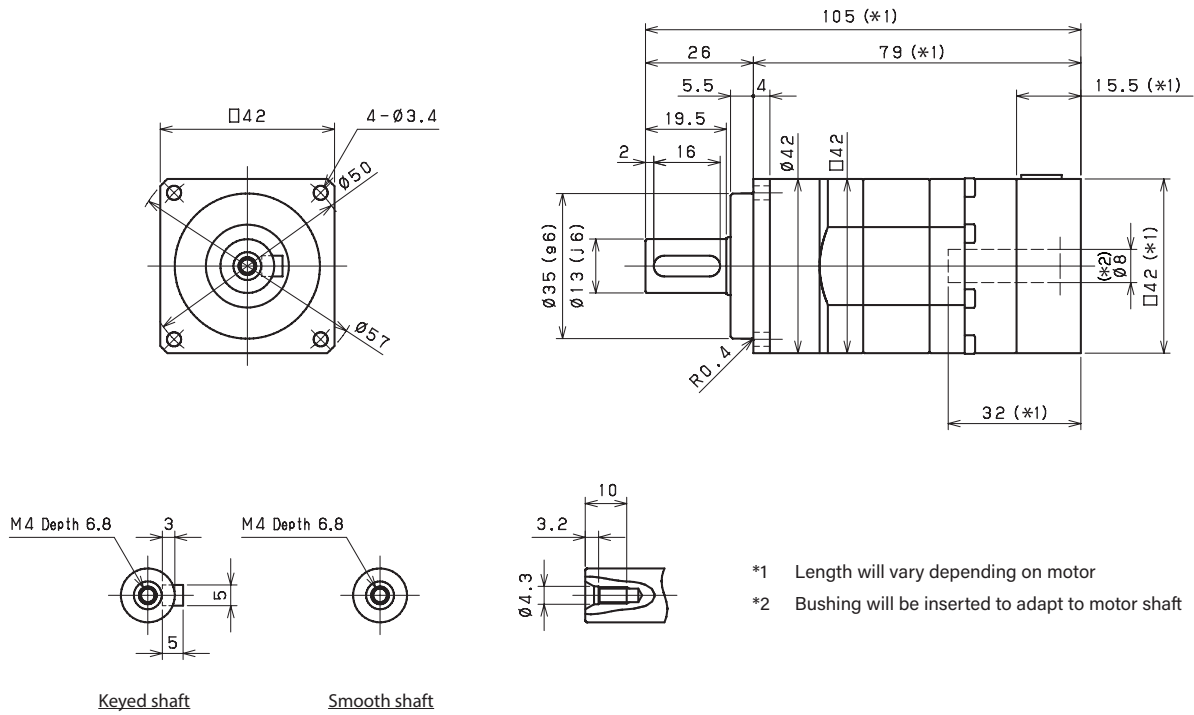

- \*1 Length will vary depending on motor
- \*2 Bushing will be inserted to adapt to motor shaft

VRB Series  
VRT  
VRS  
VRB  
VRL  
PRF  
PRE  
VRSF