

## PRF 120 1-Stage Specifications

Frame Size	120							
Ratio	Unit	Note	3	4	5	8	9	10
Nominal Output Torque	[Nm]	*1	225	330	330	330	225	225
Maximum Output Torque	[Nm]	*2	340	490	490	480	370	370
Emergency Stop Torque	[Nm]	*3	500	550	550	550	500	500
Nominal Input Speed	[rpm]	*4	3000					
Maximum Input Speed	[rpm]	*5	6000					
No Load Running Torque	[Nm]	*6	1.30					
Maximum Radial Load	[N]	*7	2000					
Maximum Axial Load	[N]	*8	2800					
Moment of Inertia ( $\leq \varnothing 19$ )	[kgcm <sup>2</sup> ]	--	2.38	1.45	1.17	0.88	0.85	0.83
Moment of Inertia ( $\leq \varnothing 28$ )	[kgcm <sup>2</sup> ]	--	4.41	3.48	3.13	2.89	2.86	2.84
Moment of Inertia ( $\leq \varnothing 38$ )	[kgcm <sup>2</sup> ]	--	12.27	11.34	11.05	10.72	10.69	10.67
Efficiency	[%]	*9	95					
Torsional Rigidity	[Nm/arc-min]	*10	15					
Maximum Torsional Backlash	[arc-min]	--	$\leq 8$					
Noise Level	dB [A]	*11	$\leq 65$					
Protection Class	*15	--	IP54					
Ambient Temperature	[°C]	--	0-40					
Permitted Housing Temperature	[°C]	--	90					
Weight	[kg]	*12	6.8					

\*1 Continuous rating at 100% duty cycle, S1 operation, measured at 100rpm output and 30°C

\*2 Permitted for 30,000 output shaft revolutions. Note operation factor on page 469

\*3 The maximum torque allowed under a stress situation. Permitted 1,000 times during service life

\*4 The average input speed at nominal torque. Maintain housing temperature below permitted value

\*5 The maximum intermittent input speed

\*6 Torque at no load applied to the input shaft at nominal input speed

\*7 The maximum radial load that the gearbox can accept

\*8 The maximum axial load that the gearbox can accept

\*9 The efficiency at the nominal output torque ratings

\*10 This does not include lost motion

\*11 Contact Nidec Drive Technology for the testing conditions and environment

\*12 Weight may vary slightly between models

## PRF 120 2-Stage Specifications

Frame Size	120											
Ratio	Unit	Note	12	15	16	20	25	32	40	50	80	100
Nominal Output Torque	[Nm]	*1	225	225	330	330	330	330	330	280	280	225
Maximum Output Torque	[Nm]	*2	270	270	390	390	390	390	390	390	390	292
Emergency Stop Torque	[Nm]	*3	500	500	550	550	550	550	550	550	550	500
Nominal Input Speed	[rpm]	*4	3000									
Maximum Input Speed	[rpm]	*5	6000									
No Load Running Torque	[Nm]	*6	0.42									
Maximum Radial Load	[N]	*7	2000									
Maximum Axial Load	[N]	*8	2800									
Moment of Inertia ( $\leq \varnothing 19$ )	[kgcm <sup>2</sup> ]	--	1.32	1.08	1.07	0.93	0.92	1.03	0.76	0.80	0.79	0.79
Moment of Inertia ( $\leq \varnothing 28$ )	[kgcm <sup>2</sup> ]	--	3.31	2.97	3.06	2.93	2.91	3.03	2.75	2.78	2.78	2.78
Moment of Inertia ( $\leq \varnothing 38$ )	[kgcm <sup>2</sup> ]	--	-	-	-	-	-	-	-	-	-	-
Efficiency	[%]	*9	90									
Torsional Rigidity	[Nm/arc-min]	*10	15									
Maximum Torsional Backlash	[arc-min]	--	$\leq 10$									
Noise Level	dB [A]	*11	$\leq 65$									
Protection Class	*15	--	IP54									
Ambient Temperature	[°C]	--	0-40									
Permitted Housing Temperature	[°C]	--	90									
Weight	[kg]	*12	8.8									

\*1 Continuous rating at 100% duty cycle, S1 operation, measured at 100rpm output and 30°C

\*2 Permitted for 30,000 output shaft revolutions. Note operation factor on page 469

\*3 The maximum torque allowed under a stress situation. Permitted 1,000 times during service life

\*4 The average input speed at nominal torque. Maintain housing temperature below permitted value

\*5 The maximum intermittent input speed

\*6 Torque at no load applied to the input shaft at nominal input speed

\*7 The maximum radial load that the gearbox can accept

\*8 The maximum axial load that the gearbox can accept

\*9 The efficiency at the nominal output torque ratings

\*10 This does not include lost motion

\*11 Contact Nidec Drive Technology for the testing conditions and environment

\*12 Weight may vary slightly between models

VRSF

PRE

PRF

VRL

VRB

VR5

VRT

# PLANETARY *Inline Gear Reducers*

## PRF 120 1-Stage Dimensions

Input bore size  $\leq \varnothing 19$  mm

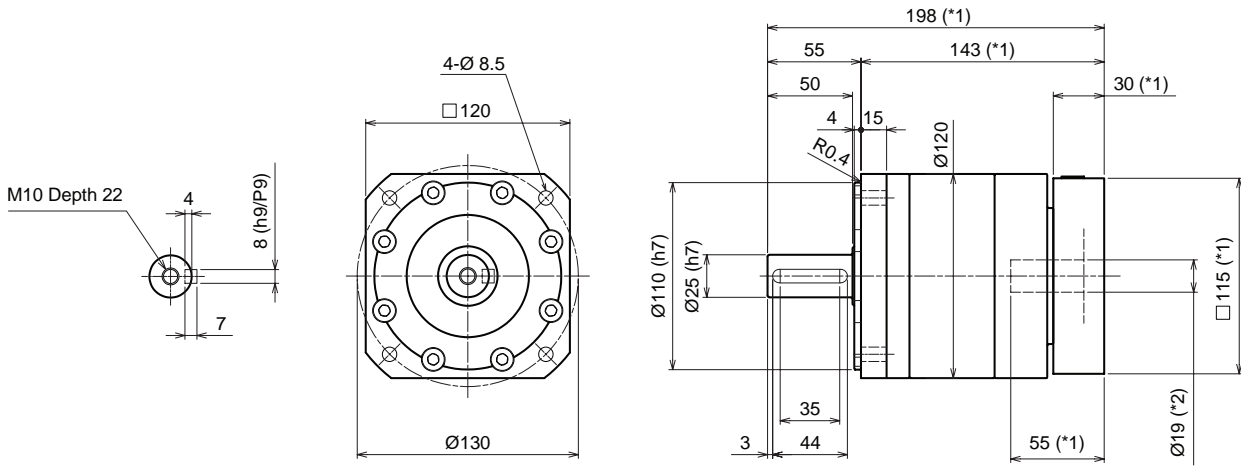

Input bore size  $\leq \varnothing 28$  mm

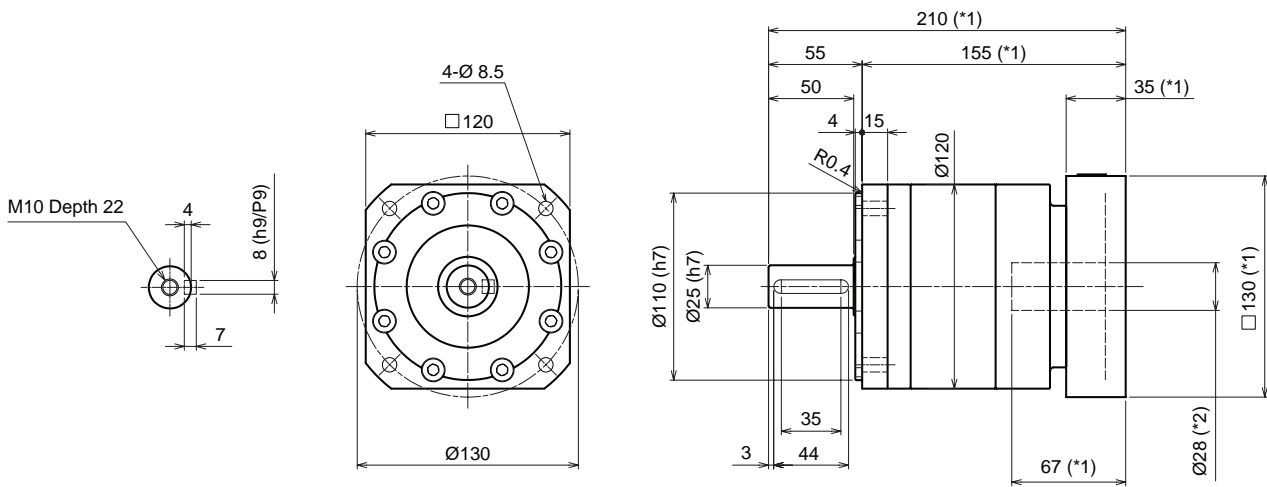

Input bore size  $\leq \varnothing 38$  mm

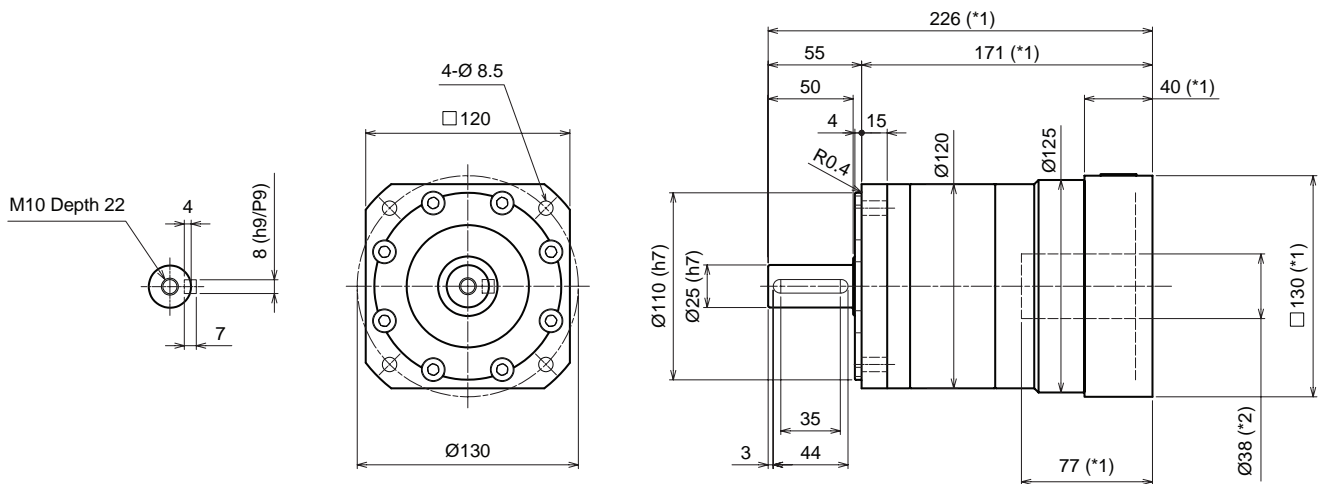

\*1 Length will vary depending on motor

\*2 Bushing will be inserted to adapt to motor shaft

## PRF 120 2-Stage Dimensions

Input bore size  $\leq \phi 19$  mm

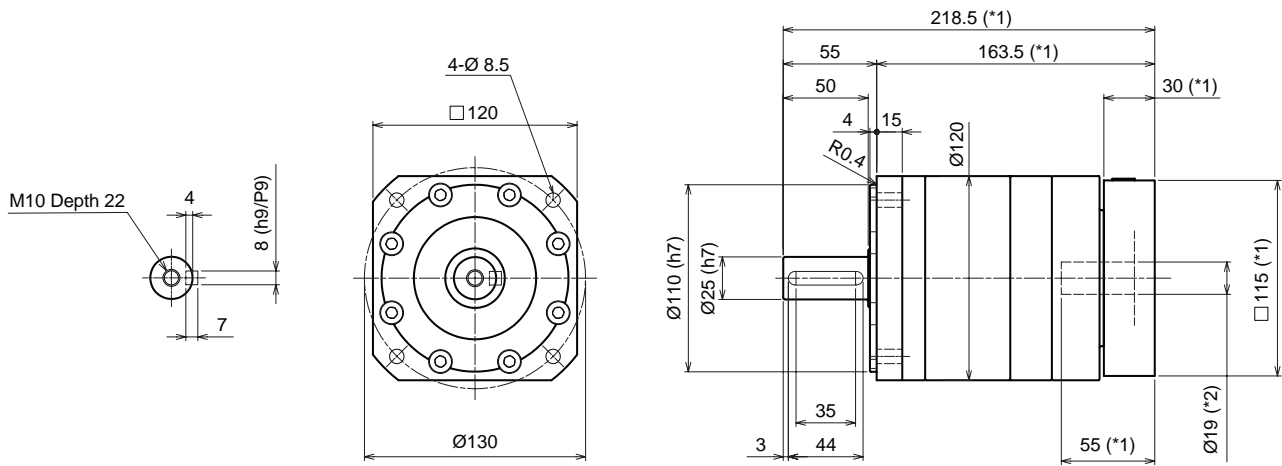

Input bore size  $\leq \phi 28$  mm

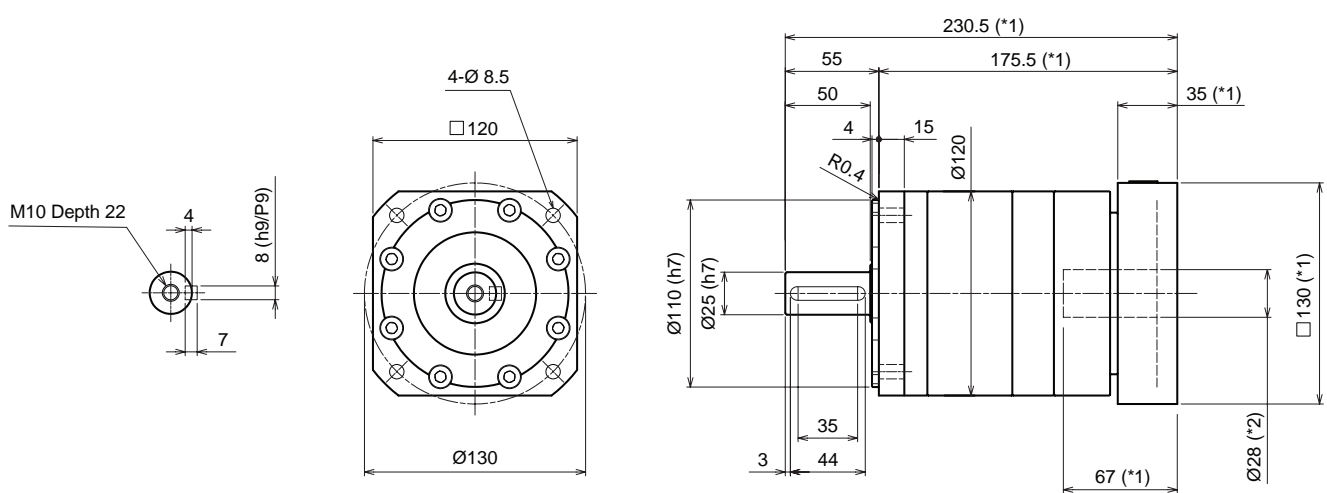

\*1 Length will vary depending on motor

\*2 Bushing will be inserted to adapt to motor shaft

VRSF

PRE

PRF

VRL

VRB

VRS

VRT