

PRE 160 1-Stage Specifications

Frame Size	160							
Ratio	Unit	Note	3	4	5	8	9	10
Nominal Output Torque	[Nm]	*1	470	700	700	700	470	470
Maximum Output Torque	[Nm]	*2	630	1000	1000	950	730	730
Emergency Stop Torque	[Nm]	*3	1000	1250	1250	1250	1000	1000
Nominal Input Speed	[rpm]	*4	2000					
Maximum Input Speed	[rpm]	*5	6000					
No Load Running Torque	[Nm]	*6	1.63					
Maximum Radial Load	[N]	*7	6100					
Maximum Axial Load	[N]	*8	9000					
Moment of Inertia ($\leq \varnothing 28$)	[kgcm ²]	--	7.17	3.67	2.62	1.60	1.50	1.43
Moment of Inertia ($\leq \varnothing 38$)	[kgcm ²]	--	17.03	13.51	12.46	11.36	11.26	11.19
Efficiency	[%]	*9	95					
Torsional Rigidity	[Nm/arc-min]	*10	45					
Maximum Torsional Backlash	[arc-min]	--	≤ 8					
Noise Level	dB [A]	*11	≤ 70					
Protection Class	--	--	IP54					
Ambient Temperature	[°C]	--	0-40					
Permitted Housing Temperature	[°C]	--	90					
Weight	[kg]	*12	16.5					

*1 Continuous rating at 100% duty cycle, S1 operation, measured at 100rpm output and 30°C

*2 Permitted for 30,000 output shaft revolutions. Note operation factor on page 469

*3 The maximum torque allowed under a stress situation. Permitted 1,000 times during service life

*4 The average input speed at nominal torque. Maintain housing temperature below permitted value

*5 The maximum intermittent input speed

*6 Torque at no load applied to the input shaft at nominal input speed

*7 The maximum radial load that the gearbox can accept

*8 The maximum axial load that the gearbox can accept

*9 The efficiency at the nominal output torque ratings

*10 This does not include lost motion

*11 Contact Nidec Drive Technology for the testing conditions and environment

*12 Weight may vary slightly between models

PRE 160 2-Stage Specifications

Frame Size	160											
Ratio	Unit	Note	12	15	16	20	25	32	40	50	80	100
Nominal Output Torque	[Nm]	*1	470	470	700	700	700	700	700	700	700	470
Maximum Output Torque	[Nm]	*2	560	560	840	840	840	840	840	840	840	610
Emergency Stop Torque	[Nm]	*3	1000	1000	1250	1250	1250	1250	1250	1250	1250	1000
Nominal Input Speed	[rpm]	*4	2000									
Maximum Input Speed	[rpm]	*5	6000									
No Load Running Torque	[Nm]	*6	0.56									
Maximum Radial Load	[N]	*7	6100									
Maximum Axial Load	[N]	*8	9000									
Moment of Inertia ($\leq \varnothing 28$)	[kgcm ²]	--	5.41	2.50	2.55	1.94	1.89	2.42	1.23	3.11	3.09	3.09
Moment of Inertia ($\leq \varnothing 38$)	[kgcm ²]	--	14.00	12.09	12.54	11.92	11.87	12.41	11.17	11.90	11.90	11.90
Efficiency	[%]	*9	90									
Torsional Rigidity	[Nm/arc-min]	*10	43									
Maximum Torsional Backlash	[arc-min]	--	≤ 10									
Noise Level	dB [A]	*11	≤ 70									
Protection Class	--	--	IP54									
Ambient Temperature	[°C]	--	0-40									
Permitted Housing Temperature	[°C]	--	90									
Weight	[kg]	*12	20.3									

- *1 Continuous rating at 100% duty cycle, S1 operation, measured at 100rpm output and 30°C
- *2 Permitted for 30,000 output shaft revolutions. Note operation factor on page 469
- *3 The maximum torque allowed under a stress situation. Permitted 1,000 times during service life
- *4 The average input speed at nominal torque. Maintain housing temperature below permitted value
- *5 The maximum intermittent input speed
- *6 Torque at no load applied to the input shaft at nominal input speed
- *7 The maximum radial load that the gearbox can accept
- *8 The maximum axial load that the gearbox can accept
- *9 The efficiency at the nominal output torque ratings
- *10 This does not include lost motion
- *11 Contact Nidec Drive Technology for the testing conditions and environment
- *12 Weight may vary slightly between models

VRSF

PRE

PRF

VRL

VRB

VRS

VRT

PLANETARY Inline Gear Reducers

PRE 160 1-Stage Dimensions

Input bore size $\leq \varnothing 28$ mm

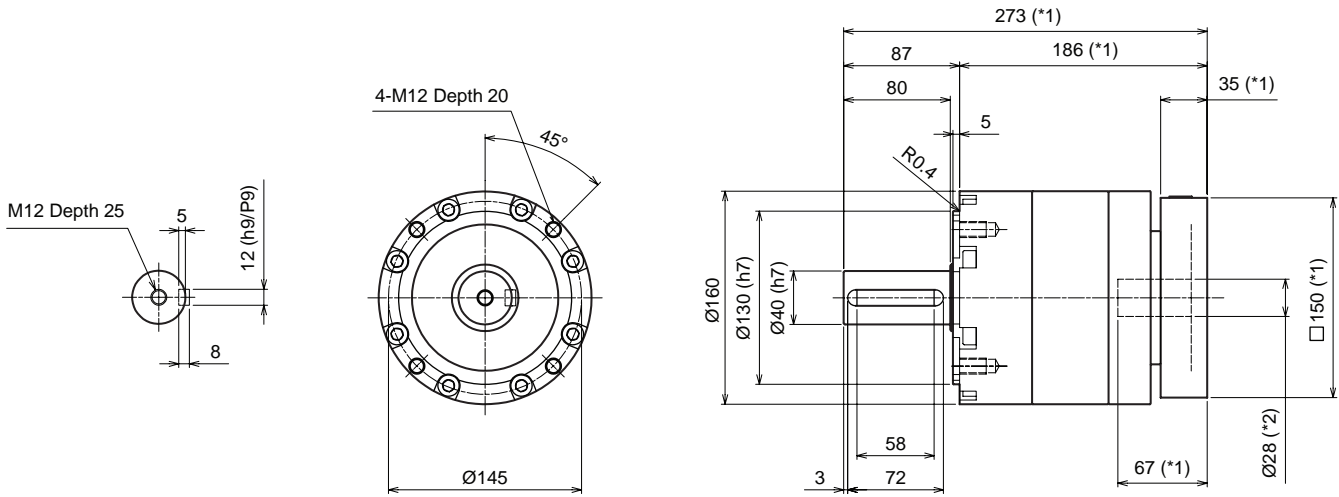

Input bore size $\leq \varnothing 38$ mm

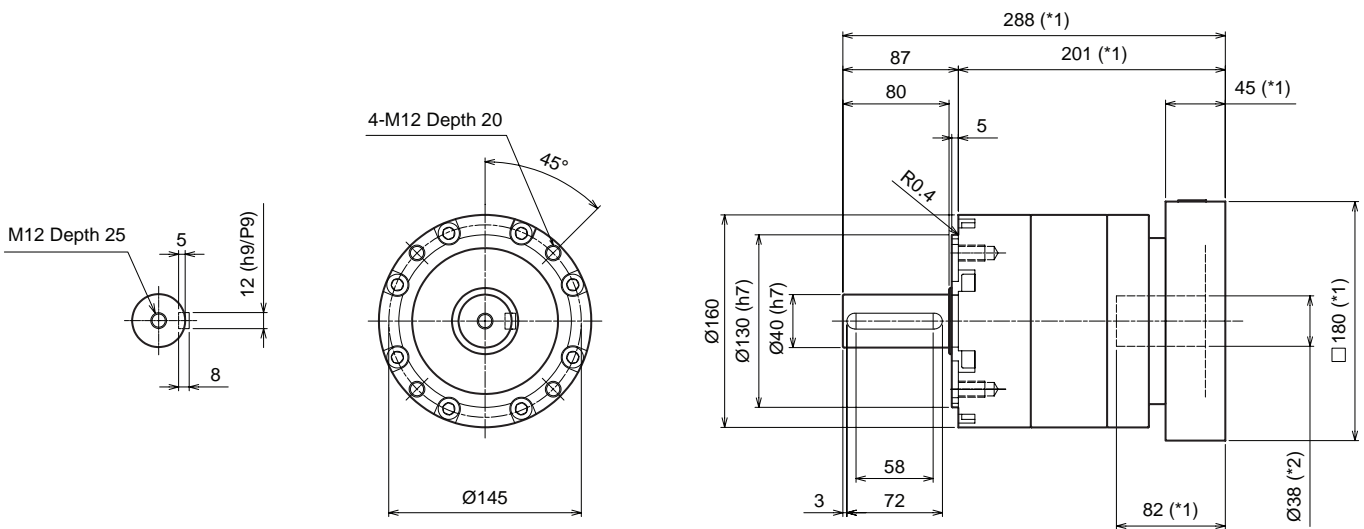

*1 Length will vary depending on motor

*2 Bushing will be inserted to adapt to motor shaft

PRE 160 2-Stage Dimensions

Input bore size $\leq \varnothing 28$ mm

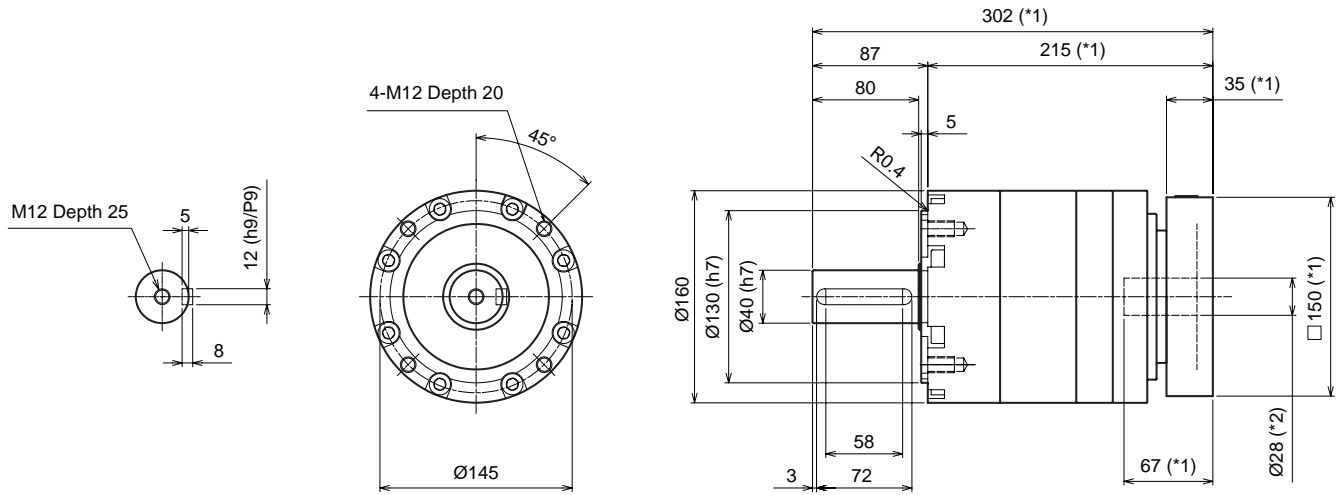

Input bore size $\leq \varnothing 38$ mm

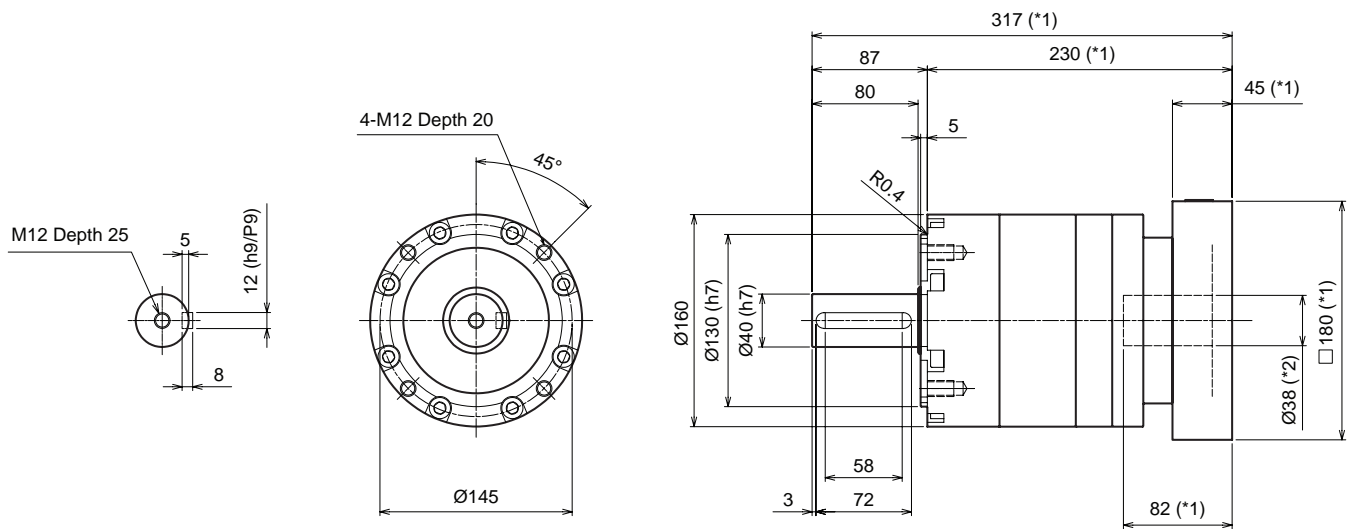

*1 Length will vary depending on motor

*2 Bushing will be inserted to adapt to motor shaft

VRSF

PRE

PRF

VRL

VRB

VRS

VRT