

PRE 082 1-Stage Specifications

Frame Size	082							
Ratio	Unit	Note	3	4	5	8	9	10
Nominal Output Torque	[Nm]	*1	80	125	125	125	80	80
Maximum Output Torque	[Nm]	*2	135	200	200	190	145	145
Emergency Stop Torque	[Nm]	*3	200	210	210	210	200	200
Nominal Input Speed	[rpm]	*4	3000					
Maximum Input Speed	[rpm]	*5	6000					
No Load Running Torque	[Nm]	*6	0.35					
Maximum Radial Load	[N]	*7	990					
Maximum Axial Load	[N]	*8	1500					
Moment of Inertia ($\leq \varnothing 14$)	[kgcm ²]	--	0.57	0.41	0.35	0.31	0.30	0.30
Moment of Inertia ($\leq \varnothing 19$)	[kgcm ²]	--	1.04	0.87	0.82	0.77	0.77	0.76
Moment of Inertia ($\leq \varnothing 28$)	[kgcm ²]	--	3.13	2.96	2.91	2.86	2.86	2.85
Efficiency	[%]	*9	95					
Torsional Rigidity	[Nm/arc-min]	*10	6					
Maximum Torsional Backlash	[arc-min]	--	≤ 8					
Noise Level	dB [A]	*11	≤ 60					
Protection Class	--	--	IP54					
Ambient Temperature	[°C]	--	0-40					
Permitted Housing Temperature	[°C]	--	90					
Weight	[kg]	*12	2.5					

*1 Continuous rating at 100% duty cycle, S1 operation, measured at 100rpm output and 30°C

*2 Permitted for 30,000 output shaft revolutions. Note operation factor on page 469

*3 The maximum torque allowed under a stress situation. Permitted 1,000 times during service life

*4 The average input speed at nominal torque. Maintain housing temperature below permitted value

*5 The maximum intermittent input speed

*6 Torque at no load applied to the input shaft at nominal input speed

*7 The maximum radial load that the gearbox can accept

*8 The maximum axial load that the gearbox can accept

*9 The efficiency at the nominal output torque ratings

*10 This does not include lost motion

*11 Contact Nidec Drive Technology for the testing conditions and environment

*12 Weight may vary slightly between models

PRE 082 2-Stage Specifications

Frame Size	082											
Ratio	Unit	Note	12	15	16	20	25	32	40	50	80	100
Nominal Output Torque	[Nm]	*1	80	80	125	125	125	125	125	120	120	80
Maximum Output Torque	[Nm]	*2	108	108	165	165	165	165	165	165	165	112
Emergency Stop Torque	[Nm]	*3	200	200	210	210	210	210	210	210	210	200
Nominal Input Speed	[rpm]	*4	3000									
Maximum Input Speed	[rpm]	*5	6000									
No Load Running Torque	[Nm]	*6	0.06									
Maximum Radial Load	[N]	*7	990									
Maximum Axial Load	[N]	*8	1500									
Moment of Inertia ($\leq \varnothing 14$)	[kgcm ²]	--	0.39	0.33	0.33	0.32	0.32	0.32	0.28	0.29	0.28	0.28
Moment of Inertia ($\leq \varnothing 19$)	[kgcm ²]	--	0.84	0.78	0.78	0.77	0.77	0.78	0.73	0.74	0.74	0.74
Moment of Inertia ($\leq \varnothing 28$)	[kgcm ²]	--	2.91	2.85	2.85	2.84	2.83	2.84	2.79	2.81	2.81	2.81
Efficiency	[%]	*9	90									
Torsional Rigidity	[Nm/arc-min]	*10	6									
Maximum Torsional Backlash	[arc-min]	--	≤ 10									
Noise Level	dB [A]	*11	≤ 60									
Protection Class	--	--	IP54									
Ambient Temperature	[°C]	--	0-40									
Permitted Housing Temperature	[°C]	--	90									
Weight	[kg]	*12	3.0									

- *1 Continuous rating at 100% duty cycle, S1 operation, measured at 100rpm output and 30°C
- *2 Permitted for 30,000 output shaft revolutions. Note operation factor on page 469
- *3 The maximum torque allowed under a stress situation. Permitted 1,000 times during service life
- *4 The average input speed at nominal torque. Maintain housing temperature below permitted value
- *5 The maximum intermittent input speed
- *6 Torque at no load applied to the input shaft at nominal input speed
- *7 The maximum radial load that the gearbox can accept
- *8 The maximum axial load that the gearbox can accept
- *9 The efficiency at the nominal output torque ratings
- *10 This does not include lost motion
- *11 Contact Nidec Drive Technology for the testing conditions and environment
- *12 Weight may vary slightly between models

VRSF
 PRE
 PRF
 VRL
 VRB
 VRS
 VRT

PLANETARY Inline Gear Reducers

PRE 082 1-Stage Dimensions

Input bore size $\leq \varnothing 14$ mm

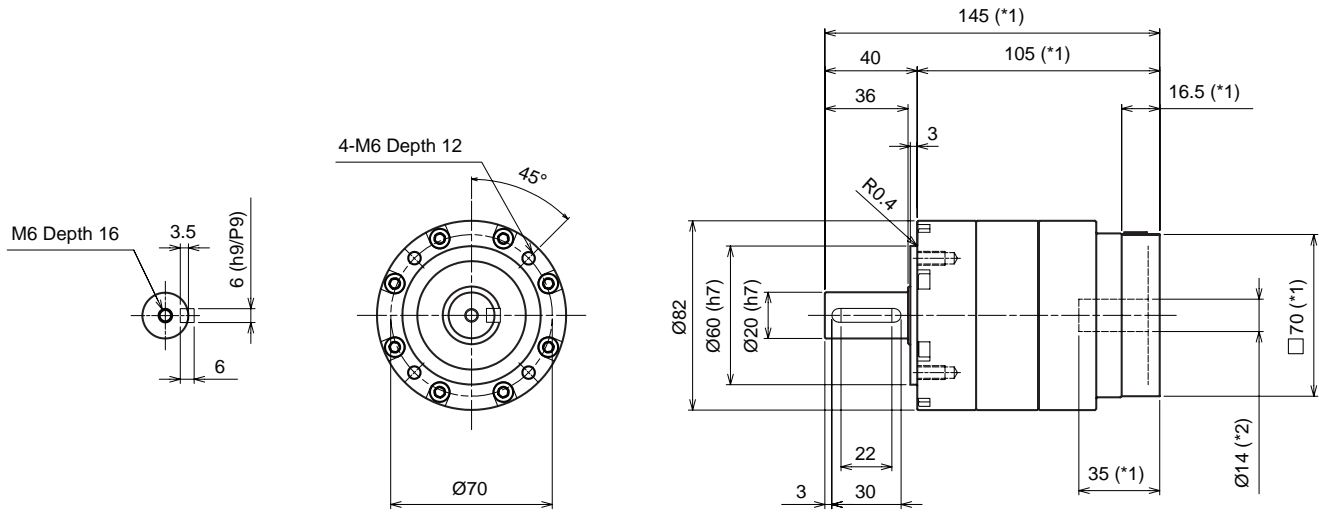

Input bore size $\leq \varnothing 19$ mm

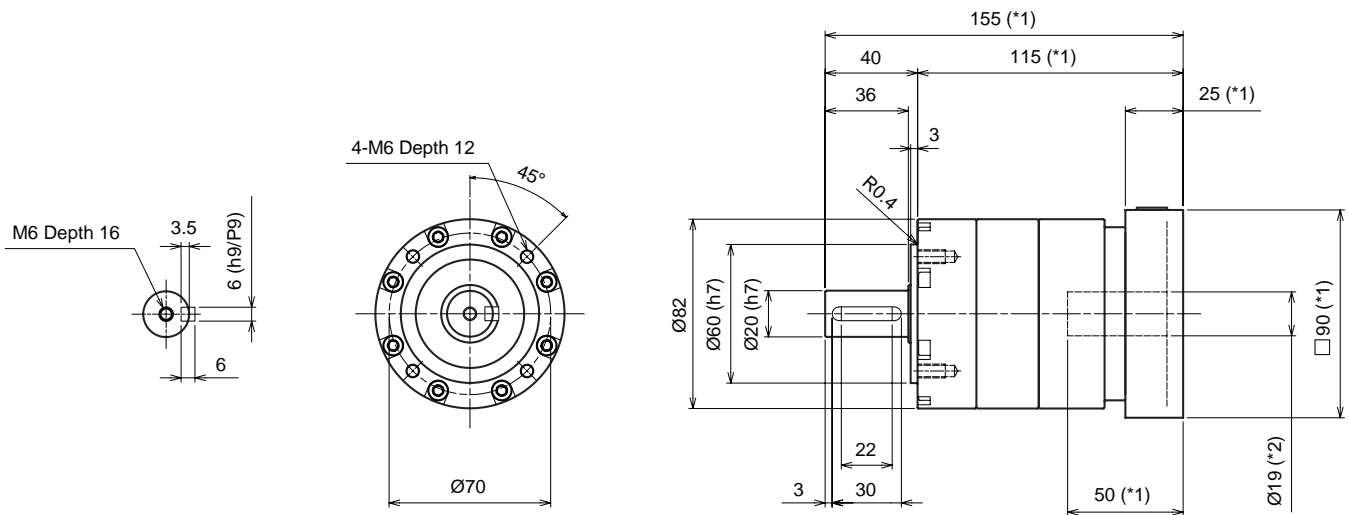

Input bore size $\leq \varnothing 28$ mm

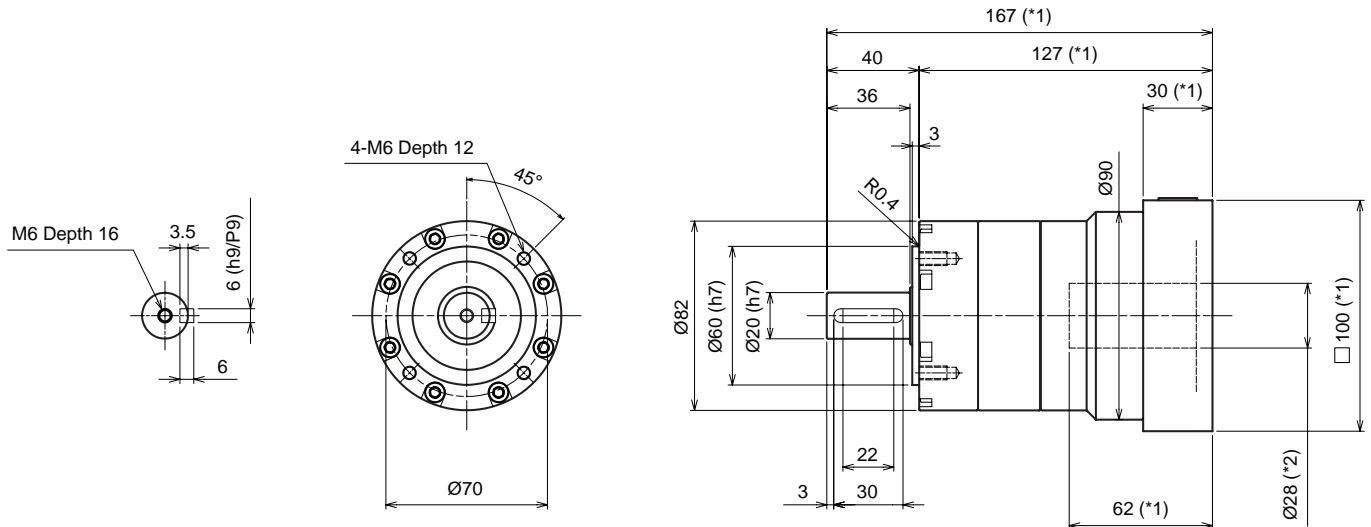

*1 Length will vary depending on motor

*2 Bushing will be inserted to adapt to motor shaft

PRE 082 2-Stage Dimensions

Input bore size $\leq \phi 14$ mm

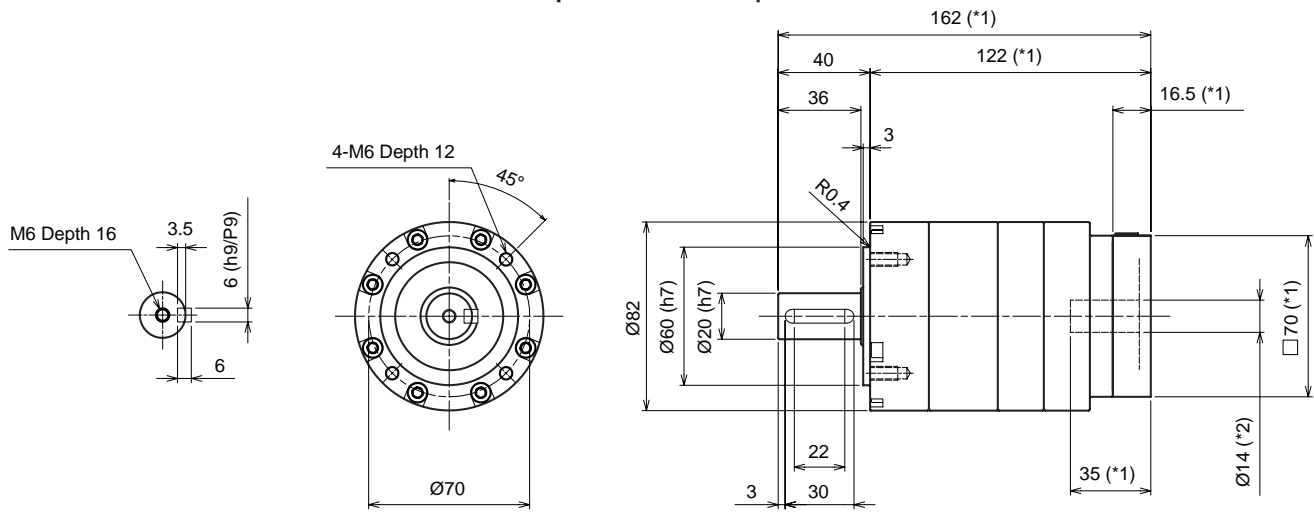

Input bore size $\leq \phi 19$ mm

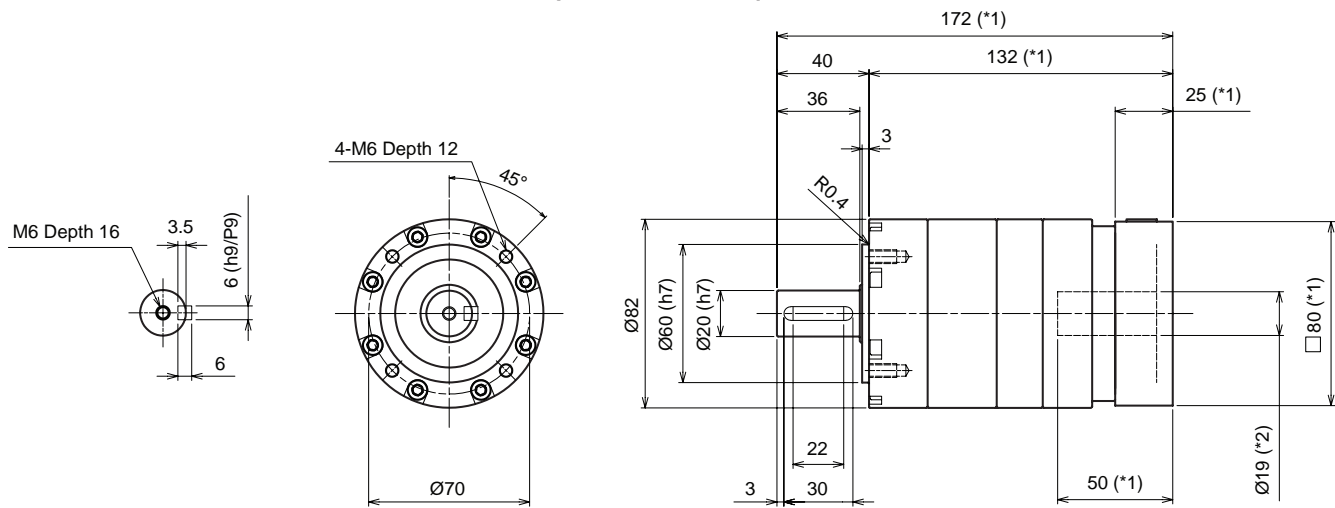

Input bore size $\leq \phi 28$ mm

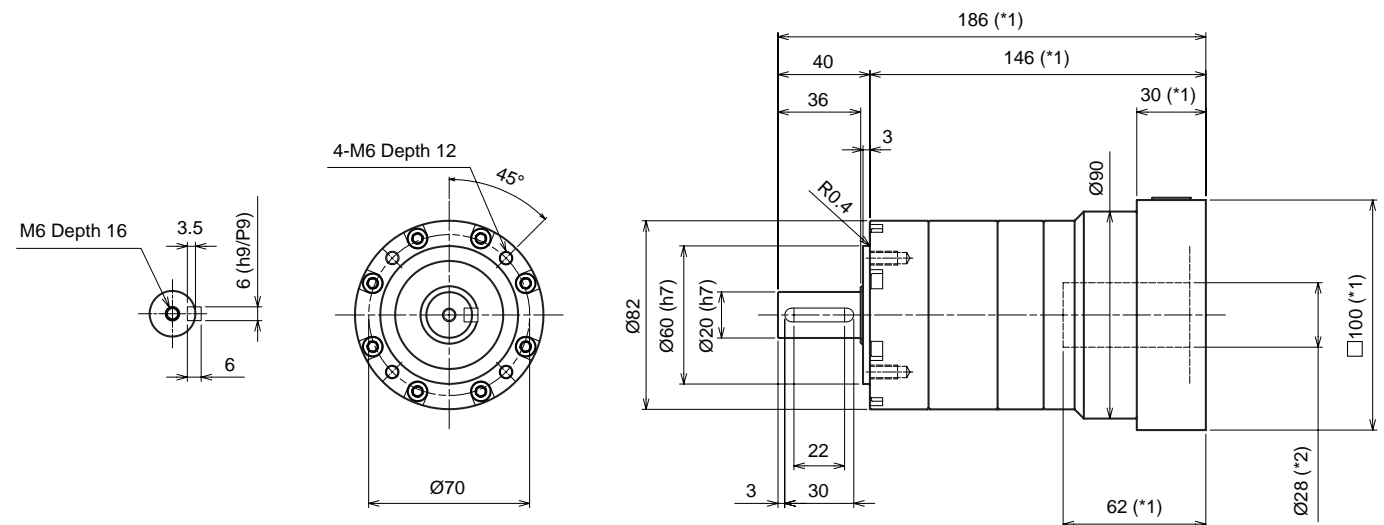

*1 Length will vary depending on motor

*2 Bushing will be inserted to adapt to motor shaft

VRSF

PRE

PRF

VRL

VRB

VRS

VRT