

Operation Manual



Warning

- Do not touch moving parts of the product while in operation. It may lead to injuries.
- Do not perform maintenance work while electrical power is supplied. Injury may result.
- Turn off the main power switch to the motor in the case of electric power down to avoid risk of sudden start after electric power recovery.
- Improper handling may cause injury or damage to the product.
- Units are not designed to be disassembled. Do not attempt.



Initial Inspection

- Confirm that you received the exact model that you ordered by checking the product label and its listed specifications.
- After opening carton, inspect for physical damage to product. If damage is suspected, make an immediate claim with the freight carrier company.

Caution

- Avoid installing the product in the following conditions:
 - Presence of vacuums or extreme pressures.
 - Existence of explosive or other hazardous gases and radioactive materials.
 - Excessive shock or forces are present.
 - High levels of electromagnetic noise is present from nearby operating machinery.
 - Locations where water, liquids, chemicals, dust or oil could come in contact with the unit.
- The product should be installed satisfying the following conditions:
 - In an environment within the 32 to 104°F (0 to 40°C) temperature range.
 - Properly grounded upon initial installation.
 - Aligned with proper orientation.
 - Not to exceed the operating conditions, such as rated torque, revolution speed, etc, specified in this manual.
- Supplied motors are not designed for hazardous atmosphere Class I or Class II locations.
- Voltage, frequency and the number of power supply phases must correspond to that shown on the nameplate. If the number of phases is not shown on nameplate, the motor is single phase. Voltage supplied must be within +/- 10% of that specified on the nameplate to avoid reduced performance and overheating.

Prior to Operation

- The reducer is ready for operation out of the box as it has been pre-filled with lubrication.
- Check the rotating direction of the output shaft, then gradually apply load.

During Operation

- In the event any of the following occurs, stop the operation:
 - Sharp temperature increases. Up to +122°F (+ 50°C) is not significant. Ensure the moving parts are not being constrained which produce excessive loads on the motor causing an overheat condition.
 - An unusual or irregular noise or vibration is present.
 - The number of revolutions becomes distinctly unstable.
 - The performance is not as expected.
- If any of the above has occurred, check the below potential causes:
 - The input speed has not exceeded the specified number of revolutions per minute.
 - Leaking, insufficient or deteriorated lubricant.
 - Axis, gear, and/or motor input damage.
 - Unstable connections.
 - Loose free, sprocket, and reducer assembly bolts.
 - Abnormal conditions in the electric system.

Operation

Connection & Parameter Set-Up

Connection of motor, amplifier, or a controller must follow the instructions of each component. Parameter set up and programming must follow the instructions of the motor, amplifier or controller.

Checking Motion

After setting up the integral motor, run the motor at low speed to check its motion. Interference, excessive inertia, or other improper conditions can lead to overheating and malfunction of the motor. If the expected motion is not obtained, stop operation immediately and check the operating conditions.

Start and stop motion is operated by a programmable controller or similar control unit. Do not start and stop by switching the main power. Refer to instruction manual of the controller utilized for detailed control methods.

Specifications

Reduction Ratio	21:1	28:1
Rated Output Speed (Motor @ 3000 rpm)	143 rpm	107 rpm
Max. Output Speed (Motor @ 4000 rpm)	190 rpm	143 rpm
Wheel Running Speed m/min (ft/min)	67 m/min (220 ft/min)	
Tire Diameter	150 mm (6")	200 mm (8")
Allowable Radial Load (*Gear Wheel)	300 kg (661 lb)	799 kg (1762 lb)

Reduction Ratio	9:1
Rated Output Speed (Motor @ 3000 rpm)	333 rpm
Max. Output Speed (Motor @ 4000 rpm)	444 rpm
Wheel Running Speed m/min (ft/min)	159 m/min (522 ft/min)
Tire Diameter	152 mm (6")
Allowable Radial Load (*Gear Wheel)	357 kg (787 lb)

	200 W		400 W		200 W	400 W
Reduction Ratio	21:1	28:1	21:1	28:1	9:1	9:1
24V Continuous Output Torque N-m (in-lb) @ 3000 rpm	13 (115)	17 (151)	25 (221)	33 (292)	5.1 (45)	10.5 (93)
24V Starting Output Torque N-m (in-lb)	45 (398)	60 (531)	46 (407)	62 (549)	19 (168)	20 (177)
48V Continuous Output Torque N-m (in-lb) @ 3000 rpm	13 (115)	17 (151)	25 (221)	33 (292)	5.1 (45)	10.5 (93)
48V Starting Output Torque N-m (in-lb)	88 (779)	117 (1035)	91 (805)	122 (1080)	38 (336)	39 (345)

Motor Specifications

24 Volt - 200W														Speed/Torque Test Date - Control set at 100% duty cycle
Rated Speed	Rated Current	Rated Power	Rated Torque	No Load Speed	No Load Current	Stall Torque	Stall Current	Voltage Constant	Torque Constant	LL Resistance	LL Inductance	Rotor Inertia	Voltage	
RPM	Amp	Watt	Nm	RPM	Amp	Nm	Amp	V/kRPM	ozin/Amp	Ohms	mH @1Khz	Oz.in. sec ²	Volts	
3000	11.6	200.00	0.67	4400	2.00	1.46	25.00	6.237	8.435	0.124	0.268	0.005	24.00	
Geared performance											Gear Ratio:	0		

24 Volt - 400W														Speed/Torque Test Date - Control set at 100% duty cycle
Rated Speed	Rated Current	Rated Power	Rated Torque	No Load Speed	No Load Current	Stall Torque	Stall Current	Voltage Constant	Torque Constant	LL Resistance	LL Inductance	Rotor Inertia	Voltage	
RPM	Amp	Watt	Nm	RPM	Amp	Nm	Amp	V/kRPM	ozin/Amp	Ohms	mH @1Khz	Oz.in. sec ²	Volts	
3000	20.6	400.00	1.30	4200	3.00	2.60	41.00	6.623	8.957	0.052	0.165	0.008	24.00	
Geared performance											Gear Ratio:	0		

48 Volt - 200W														Speed/Torque Test Date - Control set at 100% duty cycle
Rated Speed	Rated Current	Rated Power	Rated Torque	No Load Speed	No Load Current	Stall Torque	Stall Current	Voltage Constant	Torque Constant	LL Resistance	LL Inductance	Rotor Inertia	Voltage	
RPM	Amp	Watt	Nm	RPM	Amp	Nm	Amp	V/kRPM	ozin/Amp	Ohms	mH @1Khz	Oz.in. sec ²	Volts	
3000	5.8	200.00	0.67	4400	1.20	2.93	25.00	12.473	16.869	0.657	1.071	0.005	48.00	
Geared performance											Gear Ratio:	0		

48 Volt - 400W														Speed/Torque Test Date - Control set at 100% duty cycle
Rated Speed	Rated Current	Rated Power	Rated Torque	No Load Speed	No Load Current	Stall Torque	Stall Current	Voltage Constant	Torque Constant	LL Resistance	LL Inductance	Rotor Inertia	Voltage	
RPM	Amp	Watt	Nm	RPM	Amp	Nm	Amp	V/kRPM	ozin/Amp	Ohms	mH @1Khz	Oz.in. sec ²	Volts	
3000	10.3	400.00	1.30	4750	2.00	4.64	41.00	12.264	16.586	0.254	0.535	0.008	48.00	
Geared performance											Gear Ratio:	0		

Wiring the SU Gear Motor Assembly

The standard connections for the SU Series Gear Motor Assembly are made using flying leads to allow connection to various control and wire harness configurations. Cables provided have 36" (91 cm) lengths. Recommended Wire Size: 22-26 AWG. Depending on options ordered will determine number of cables present. See chart below for various wiring configurations.

Power Cable		Brake Cable	
24 V or 48 V		Present if Option Ordered	
Color Wire	Function	Color Wire	Function
Red	Phase (A)	Red	24 V +
Black	Phase (B)	Black	24 V -
Black	Phase (C)		

I/O Cable	
Wire Color	Function
Grey/White	+5VDC
White/Grey	Ground
Green/White	Hall A
White/Green	Hall B
Brown/White	Hall C

I/O Cable Continued	
Wire Color	Function
Encoder Wiring if ordered	
Orange/White	Differential Encoder A+
White/Orange	Differential Encoder A-
Blue/White	Differential Encoder B+
White/Blue	Differential Encoder B-
* If Index 256 ppr Encoder option (5) chosen	
White/Blue	Index Channel
Orange/White	Encoder A
Blue/White	Encoder B
Thermistor Wiring if ordered	
Blue/Red	Thermistor (A)
Red/Blue	Thermistor (B)

Hall Effect

The hall signals can be used to provide inexpensive speed feedback to the motor drive.

The external module uses three Hall Effect devices to provide the commutation signals. The Hall Effect devices sense the magnet field produced by a magnetized wheel attached to the motor shaft. The hall position signal output consists of three square wave signals phased 120° apart.

Hall Effect Specifications

Absolute Maximum Ratings

Characteristics	Symbol	Notes	Rating	Units
Forward Supply Voltage [1]	VCC		26.5	V
Reverse Supply Voltage [1]	VROC		-30	V
Output Off Voltage [1]	VOUT		26	V
Continuous Output Current	IOUT		25	mA
Reverse Output Current	IROUT		-50	mA
Operating Ambient Temperature	TA	Range L	-40 to 150	°C
Maximum Junction Temperature	TJ (max)		165	°C
		For 500 hours	175	°C
Storage Temperature	Tstg		-65 to 170	°C

[1] This rating does not apply to extremely short voltage transients such as Load Dump and/or ESD. Those events have individual rating, specific to the respective transient voltage event.

Differential Encoder Option

For more precise control, the control module may contain an optional shaft mounted two-channel optical encoder. The encoder outputs two channel quadrature signals (90° out of phase) with complements. The quadrature nature of an encoder allows the user to determine the direction of motor rotation as well as speed. Speed and direction can be determined by using the quadrature signals (S). Encoder may also contain an optional index pulse version (incremental). The index pulse is generated once per revolution and the width is typically 90 electrical degrees. The encoder outputs can be used by an external drive to close the speed loop. The external encoder control provides a standard system for rotor position sensing required by many brushless motor drives.

ENCODER SPECIFICATIONS

Environment: Installation and operating conditions should not exceed the recommended values for humidity and temperature. Contact the sales department regarding any special installation issues you may have regarding vapors, oils or dust.

Storage Temp.: -40 to 85°C (-40 to 185°F)

Humidity: 40 to 90% Max. Non-condensing

Operating Temp.: 0 to 60°C (32 to 140°F)

Power: A regulated DC source must be provided for the encoder and hall devices. Observe the correct polarity when making these connections. Supply voltage ripple can cause shortened product life.

Minimum DC Voltage: 4.75 Vdc

Maximum DC Voltage: 5.25 Vdc

Output Format: Two Channel Quadrature with complements. Optional Index pulse available (incremental only).

Encoder Type: Differential. 256 PPR Index version incremental

Supply Voltage: +5 Vdc ±5%.

Supply Current No Index: 20 mA Typical

Supply Current with Index: 90 mA Typical

Output Type: Square Wave

Frequency Response: 20 kHz; Velocity (rpm x N) /60; N= number of Counts per Revolution

Standard Counts per Revolution (CPR): 100, 250, 400, 1000

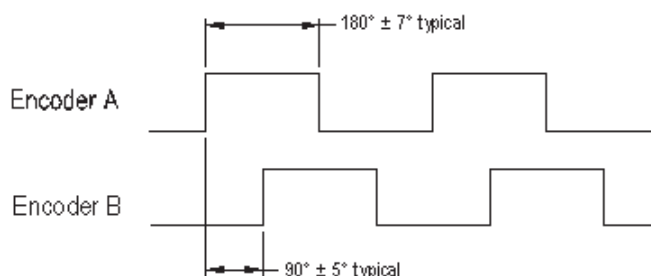

Optional Thermal Protection NTC Thermistor

Thermistor Specifications		
Parameter	Value	Unit
Resistance Value at 25°C	4.7 K	Ω
Tolerance on R25-value	± 2	%

Optional Wheel/Tire

The Gear Motor drive assembly offers optional wheel as well as a wheel with integral tire.

Wheel Specifications

Wheel Diameter: 21:1 = 5.2" (132 mm); 28:1 = 6.9" (176 mm)

Wheel + Tire Diameter: 21:1 = 5.9" (150 mm) ; 28:1 = 7.9" (200 mm); 9.1 = 6" (152 mm)

Tire Specifications

Tire Material: 21:1 & 28:1 - PTMEG (Polytetramethylene ether glycol); 9.1 - Polyurethane

Hardness: JIS A, 95

If maintenance is required to remove the wheel, to reinstall, apply a torque of 10 N-m (88.5 in-lb) to the mounting bolts for proper installation of the wheel.

Troubleshooting

Symptom	Possible Causes	Potential Corrective Action
1. Motor Fails to Start	-Motor thermal overload (if present) tripped	Turn off motor. Allow motor to cool down.
	-Improper connections	Turn off motor. Verify connections against wiring chart supplied.
	-Overloaded motor	Reduce or remove load during starting or replace with motor of higher horsepower rating.
2. Motor does not come up to speed or takes too long to accelerate	-Application issue	Larger horsepower rating may be required.
	-Voltage too low at motor	Increase wire size. Ensure wiring connections are secure and not loose.
	-Overloaded motor	Reduce or remove load during starting or replace with motor of higher horsepower rating.
3. Motor stalls during operation	-Voltage too low at motor wiring connections	Increase wire size. Ensure operation are secure and not loose.
	-Overloaded motor	Reduce or remove load during starting or replace with motor of higher horsepower rating.
4. Motor vibrates or is excessively noisy	-High voltage	Voltage at motor should be no more than 10% above nameplate voltage.
5. Motor overheats while running under load	-Overloaded motor	Reduce or remove load during starting or replace with motor of higher horsepower rating.
	-High or low voltage	Voltage at motor should be no more than 10% above or below nameplate voltage.
	-Loose or faulty connections at motor	Turn off motor. Examine wiring connections. If there are signs of discoloration, use new terminals or freshly stripped wires to properly reconnect .

Dimensions

21:1 200W

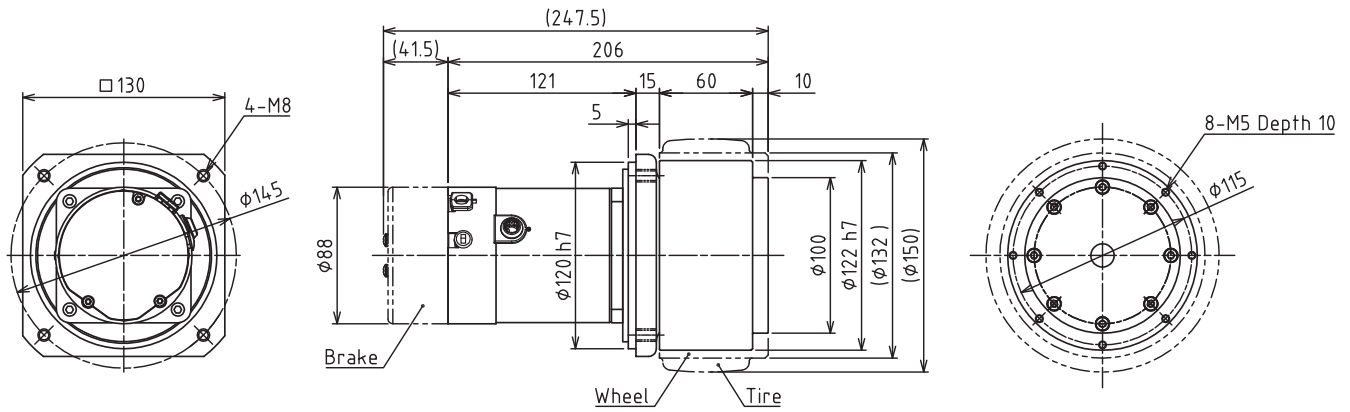

21:1 400W

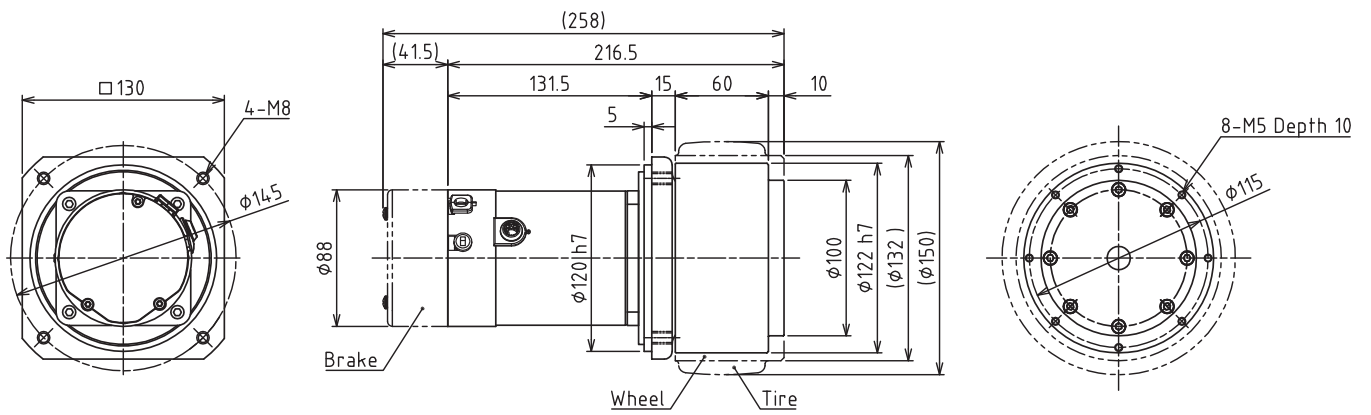

28:1 200W

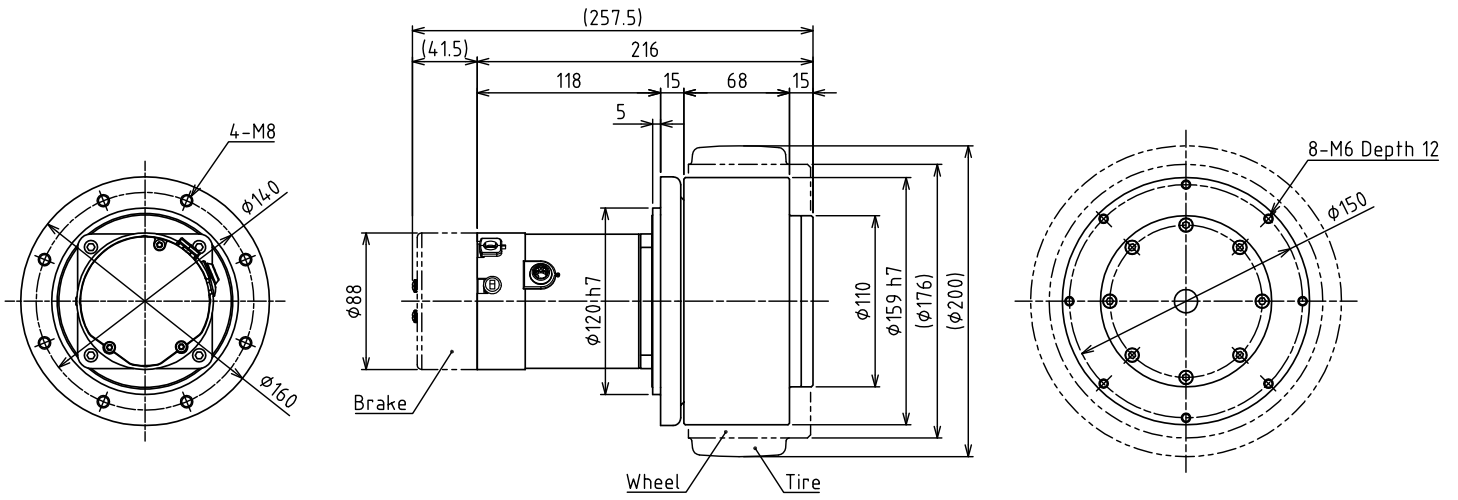

28:1 400W

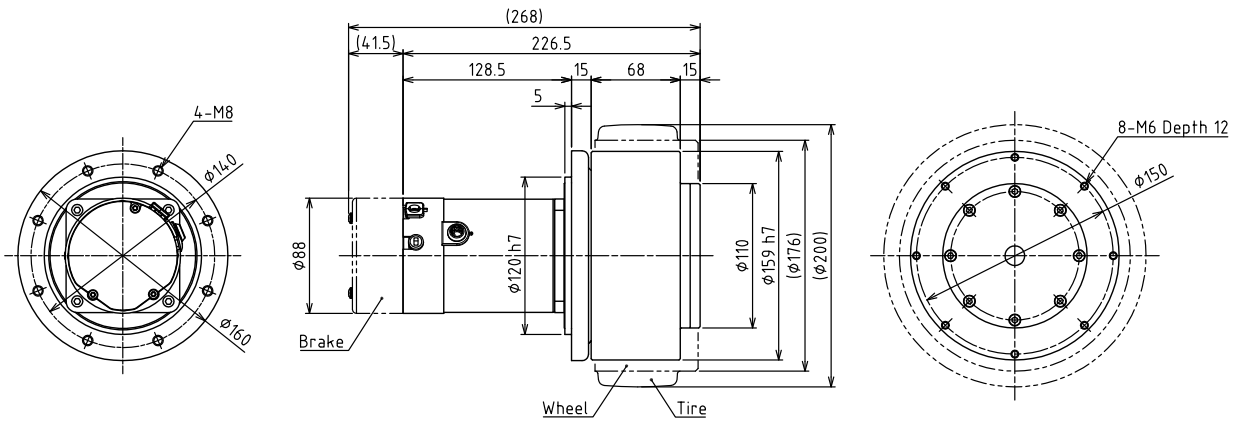

9:1 200W

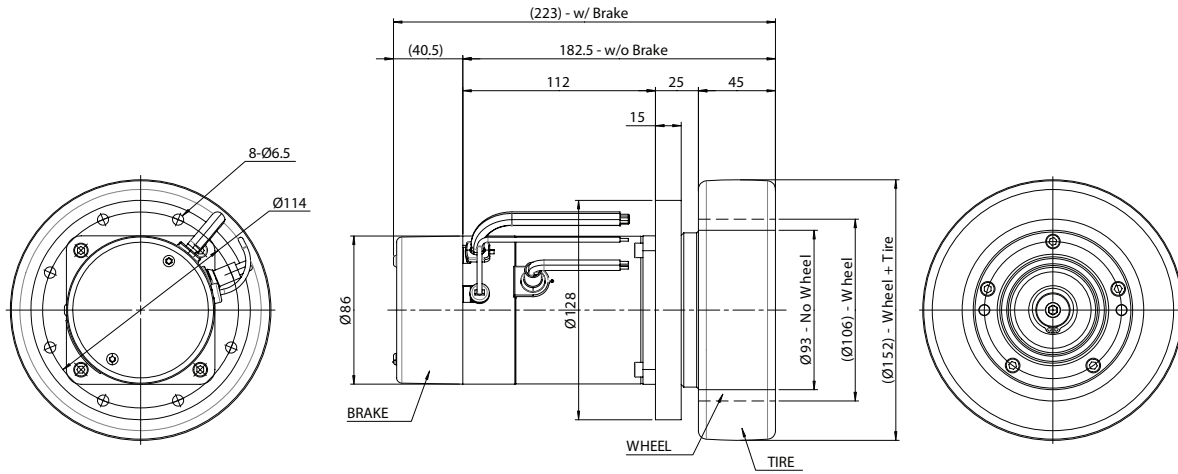

9:1 400W

