

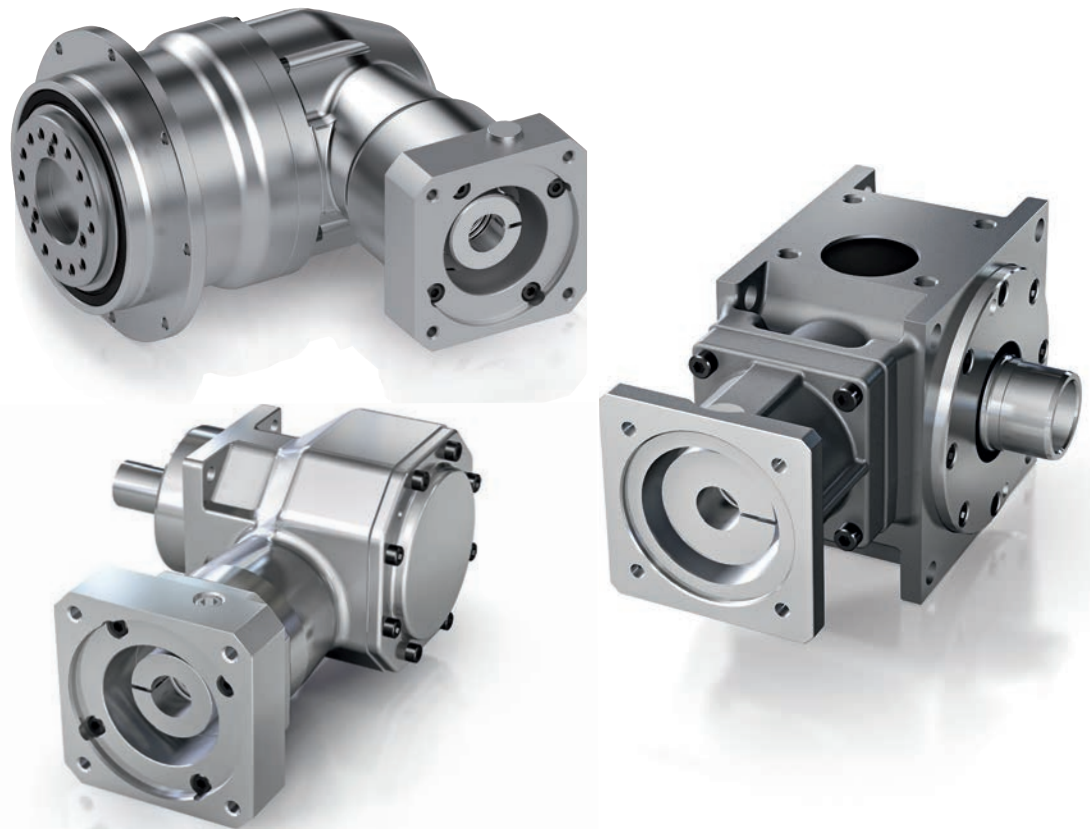

# Highly Dynamic Servo Hypoid Gearboxes



DynaGear, DynaGear Eco and EvoGear Series

Reliable and Highly Efficient

**NIDEC DRIVE TECHNOLOGY CORPORATION**

## Legacy of Innovation in Hypoid Gearing

Nidec Drive Technology Corporation acquired MS-Graessner GmbH & Co. KG, based out of Dettenhausen, Germany, in 2018. This strategic acquisition gives us over 60 years of design and manufacturing experience in the area of high precision helical bevel, spiral bevel and hypoid gears. It strengthens our position in the European market by giving our global customer base unparalleled access to a broad range of gear technologies with local product distribution and expertise.

By way of the Gleason manufacturing process, our Dettenhausen facility and highly skilled 120-person workforce excels in producing solutions for custom and highly specialized applications. Whether it's for a specific single piece project or for mass production, we develop the best possible engineering solution—providing more power density, less noise, higher efficiency and more precision at every turn.

Our hypoid product families—DynaGear, DynaGear Eco and EvoGear—were developed as a result of in-depth knowledge of different industry sectors and applications. We offer a wide range of frame sizes, ratios and mounting configurations to meet virtually any requirement. The success of our customers is the top priority for Nidec DTC. Our product quality, reliability and availability give our customers a competitive advantage as they continue to improve their machine performance to compete globally.



# Index

## DynaGear

Overview.....	2
Featured Highlights.....	4
Model Code.....	5
Performance Specifications.....	6
Dimensions and Configurations.....	8

## DynaGear Eco

Overview.....	12
Featured Highlights.....	14
Model Code.....	15
Performance Specifications.....	16
Dimensions and Configurations.....	17

## EvoGear

Overview.....	18
Featured Highlights.....	20
Model Code.....	21
Performance Specifications.....	22
Dimensions and Configurations.....	24

## Gearbox Selection & Maintenance

Gearbox Selection Procedure.....	28
Gearbox Maintenance & Lubrication.....	29



# DYNAGEAR SERIES

DynaGear was developed for highly dynamic servo applications requiring exceptional accuracy and efficiency in a compact footprint. DynaGear uses optimized hypoid gears for high, smooth torque transfer with backlash as low as  $< 2$  arc-min. Tapered roller bearings on the input and output sides of the gearbox absorb high radial and axial loads, ensuring long service life. A planetary input is used to achieve higher ratios.

DynaGear uses a weight efficient one-piece aluminum housing for high stability under load. Versatile output mounting options include solid shaft, hollow shaft, dual shaft and robot flange. The extremely compact design provides significant space savings for small installation envelopes. Lubricated for life, DynaGear is a reliable maintenance-free solution.

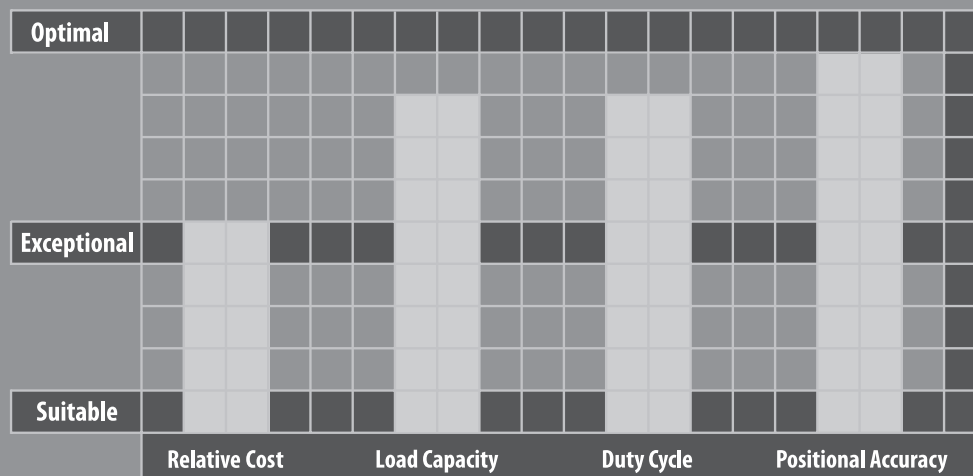



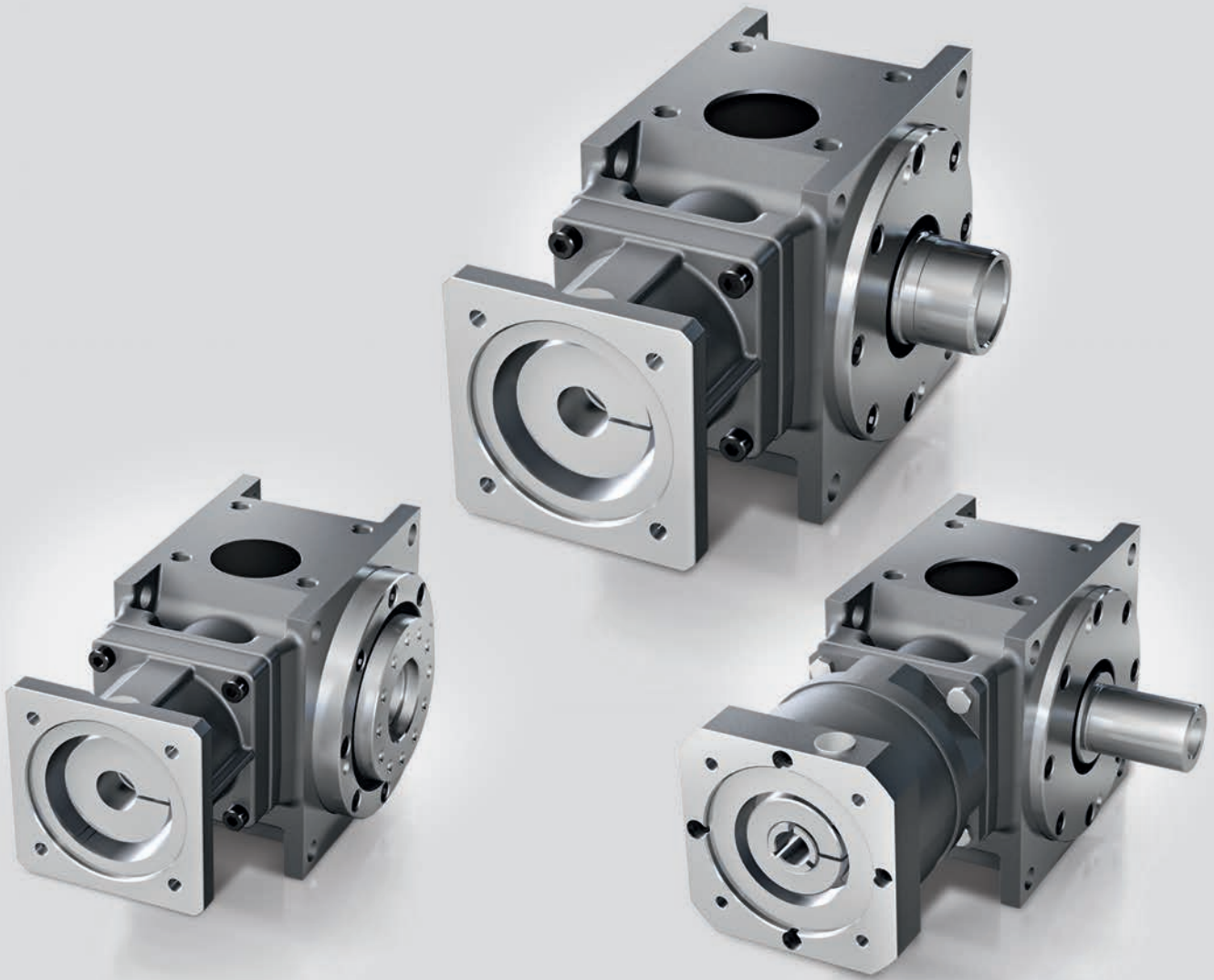

## DYNAGEAR SERIES

- Highest quality hypoid gearing with optimized contact pattern combines the space and configuration advantages of worm gearing with the high efficiencies of bevel gearing
- Extremely low backlash (<2 arc-min available), high torsional stiffness, smooth torque transmission and negligible noise. Efficiency as high as 96%
- 9 Frame sizes, 18 reduction ratios and 4 output mounting configurations
- Compact, rigid, weight efficient design
- Maintenance-free solution that is lubricated for life
- Assembled in Germany

## Featured Highlights

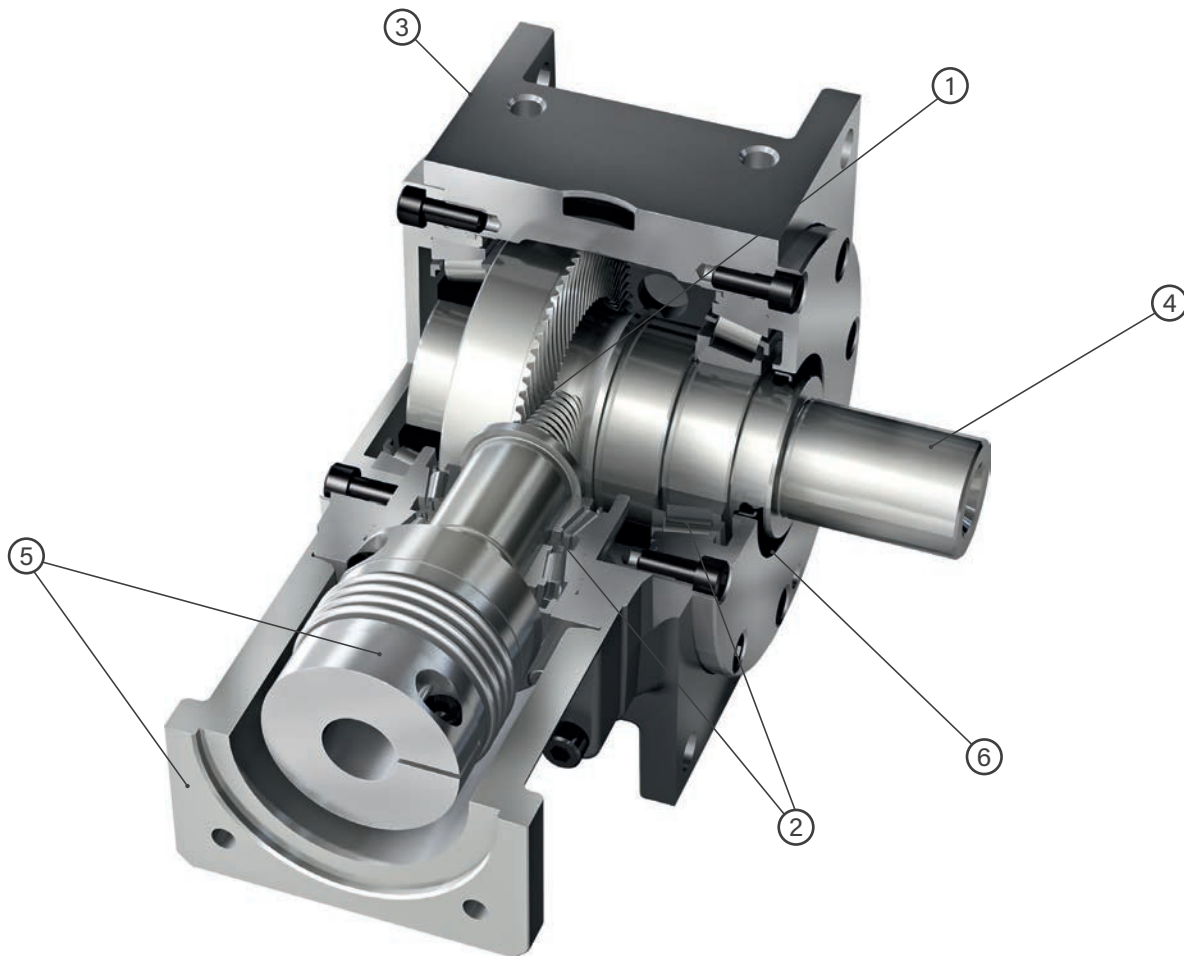

- ① Hypoid gearing with optimized contact pattern for uniform load distribution
- ② Tapered roller bearings at input and output for high radial and axial load capacity
- ③ Weight efficient one-piece aluminum housing ensuring high stability under load
- ④ Four output mounting styles for maximum flexibility: Solid shaft, hollow shaft, dual shaft, ISO 9409-1 robot flange
- ⑤ Simple, low inertia connection to various servo motors using adapter flange and stiff zero backlash coupling
- ⑥ Output seal allows for IP64 protection

## Model Code

<b>D</b>	<b>75</b>	<b>8</b>	<b>1L</b>	<b>XXX</b>
Series Name	Frame Size	Ratio	Output Mounting Type	*Motor Mounting Code
D DynaGear	37 55 75 90 115 130 140 160 190	3 4 5 6 8 10 12 15 16 18 24 30 32 40 50 60 80 100	1L: Solid Shaft Left 3L: Solid Shaft Right 13L: Dual Solid Shaft 1LSV: Hollow Shaft Right 3LSV: Hollow Shaft Left 1RFH: Robot Flange Left 3RFH: Robot Flange Right	Motor mounting code varies depending on the motor

\* Motor mounting code varies depending on the motor. Contact us to configure the code.

## Performance Specifications

Frame Size	Units	Note	37	55	75	90	115	130	140	160	190
<b>Ratio</b>	<b>i</b>		<b>3/4/5/6/8/10</b>								
Nominal Output Torque	T2N [Nm]	*1	22	35	70	140	260	430	720	1100	1440
Maximum Acceleration Torque	T2B [Nm]	*2	33	53	105	210	390	645	1080	1650	2160
Emergency Stop Torque	T2Not [Nm]	*3	44	70	140	280	520	860	1440	2200	2880
Nominal Input Speed (Ratios 3/4/5)	n1N [rpm]	*4	2300	2100	1800	1500	1150	1000	700	600	550
Nominal Input Speed (Ratios 6/8/10)	n1N [rpm]	*4	3700	3200	2700	2200	1800	1500	1200	1100	1000
Maximum Input Speed	n1max [rpm]	*5	8000	8000	8000	7000	6000	5000	5000	4500	4500
Maximum Radial Load	F2Rmax [N]	*6	2200	3300	4900	7200	10000	12600	15000	18000	22500
Maximum Axial Load	F2Amax [N]	*7	1100	1650	2450	3600	5000	6300	7500	9000	11250
Efficiency	h [%]	*8	> 96	> 96	> 96	> 96	> 96	> 96	> 96	> 96	> 96
Torsional Rigidity	Ct21 [Nm/arcmin]	*9	1.3	2.1	4.2	10.5	23.4	39.6	61.8	90	126
Maximum Torsional Backlash (Standard)	jt [arcmin]	*10	≤ 5	≤ 5	≤ 5	≤ 4	≤ 4	≤ 4	≤ 4	≤ 4	≤ 4
Maximum Torsional Backlash (Reduced)	jt [arcmin]	*10	-	-	≤ 3	≤ 2	≤ 2	≤ 2	≤ 2	≤ 2	≤ 2
Noise Level	LpA [dB(A)]	*11	< 65	< 66	< 66	< 68	< 68	< 70	< 70	< 72	< 72
Ambient Temperature	[°C]	-	-10 to 90								
Permitted Housing Temperature	[°C]	-	90								
Protection Class	-	-	IP64								
Lubrication	-	-	Synthetic Oil [ISO VG-Class 150]								
Service Life	SL [h]	*12	30,000								
Weight	m [kg]	-	1.9	3.5	5.5	9.5	15.5	23.5	32.5	46.5	60

Frame Size	Units	Note	37	55	75	90	115	130	140	160	190
<b>Ratio</b>	<b>i</b>		<b>12/15</b>								
Nominal Output Torque	T2N [Nm]	*1	15	25	50	95	180	300	510	815	1020
Maximum Acceleration Torque	T2B [Nm]	*2	22	38	75	143	270	450	765	1223	1530
Emergency Stop Torque	T2Not [Nm]	*3	30	50	100	190	360	600	1020	1630	2040
Nominal Input Speed	n1N [rpm]	*4	4500	3900	3300	2800	2300	2000	1600	1350	1300
Maximum Input Speed	n1max [rpm]	*5	8000	8000	8000	7000	6000	5000	5000	4500	4500
Maximum Radial Load	F2Rmax [N]	*6	2200	3300	4900	7200	10000	12600	15000	18000	22500
Maximum Axial Load	F2Amax [N]	*7	1100	1650	2450	3600	5000	6300	7500	9000	11250
Efficiency	h [%]	*8	> 93	> 93	> 93	> 93	> 93	> 93	> 93	> 93	> 93
Torsional Rigidity	Ct21 [Nm/arcmin]	*9	1.3	2.1	4.2	10.5	23.4	39.6	61.8	90	126
Maximum Torsional Backlash (Standard)	jt [arcmin]	*10	≤ 5	≤ 5	≤ 5	≤ 4	≤ 4	≤ 4	≤ 4	≤ 4	≤ 4
Maximum Torsional Backlash (Reduced)	jt [arcmin]	*10	-	-	≤ 3	≤ 2	≤ 2	≤ 2	≤ 2	≤ 2	≤ 2
Noise Level	LpA [dB(A)]	*11	< 65	< 66	< 66	< 68	< 68	< 70	< 70	< 72	< 72
Ambient Temperature	[°C]	-	-10 to 90								
Permitted Housing Temperature	[°C]	-	90								
Protection Class	-	-	IP64								
Lubrication	-	-	Synthetic Oil [ISO VG-Class 150]								
Service Life	SL [h]	*12	30,000								
Weight	m [kg]	-	1.9	3.5	5.5	9.5	15.5	23.5	32.5	46.5	60

Frame Size	Units	Note	-	55	75	90	115	130	140	160	190
<b>Ratio</b>	<b>i</b>		<b>16/18/24/30/32/40/50/60/80/100</b>								
Nominal Output Torque	T2N [Nm]	*1	-	35	70	140	260	430	720	1100	1440
Maximum Acceleration Torque	T2B [Nm]	*2	-	53	105	210	390	645	1080	1650	2160
Emergency Stop Torque	T2Not [Nm]	*3	-	70	140	280	520	860	1440	2200	2880
Nominal Input Speed	n1N [rpm]	*4	-	3500	3000	3000	2500	2500	2500	2500	2500
Maximum Input Speed	n1max [rpm]	*5	-	6000	6000	6000	6000	5000	5000	4500	4500
Maximum Radial Load	F2Rmax [N]	*6	-	3300	4900	7200	10000	12600	15000	18000	22500
Maximum Axial Load	F2Amax [N]	*7	-	1650	2450	3600	5000	6300	7500	9000	11250
Efficiency	h [%]	*8	-	> 92	> 92	> 92	> 92	> 92	> 92	> 92	> 92
Torsional Rigidity	Ct21 [Nm/arcmin]	*9	-	2.1	4.1	10.2	22.8	37.8	60.1	86.5	119.2
Maximum Torsional Backlash (Standard)	jt [arcmin]	*10	-	≤ 7	≤ 7	≤ 6	≤ 6	≤ 6	≤ 6	≤ 6	≤ 6
Maximum Torsional Backlash (Reduced)	jt [arcmin]	*10	-	≤ 5	≤ 5	≤ 3	≤ 3	≤ 3	≤ 3	≤ 3	≤ 3
Noise Level	LpA [dB(A)]	*11	-	< 66	< 66	< 68	< 68	< 70	< 70	< 72	< 72
Ambient Temperature	[°C]	-	-10 to 90								
Permitted Housing Temperature	[°C]	-	90								
Protection Class	-	-	IP64								
Lubrication	-	-	Synthetic Oil [ISO VG-Class 150], DIN 51818 Synthetic Grease								
Service Life	SL [h]	*12	30,000								
Weight	m [kg]	-	-	4	6.5	12.5	19.5	27	36	49	61.5

\*1 At nominal input speed, service life is 30,000 hours.

\*2 The maximum torque when starting or stopping operation. Permitted 1,000 cycles/hour.

\*3 The maximum torque allowed under a stress situation. Permitted 1,000 times during service life.

\*4 The average input speed at nominal input torque. Maintain housing temperature below permitted value.

\*5 The maximum intermittent input speed.

\*6 The maximum radial load the gearbox can accept. Measured at center of output shaft at 400rpm output.

\*7 The maximum axial load the gearbox can accept. Measured at center of output shaft at 400rpm output.

\*8 The efficiency at full load.

\*9 At nominal output torque. Does not include lost motion.

\*10 Measured at output, 2% load and max 10Nm.

\*11 Measured at 3,000 rpm input.

\*12 Based on S5 duty cycle <60% and <20 minute run time.



## Performance Specifications

Moment of inertia  $I_1$  [kgcm<sup>2</sup>]

Ratio	Frame Size								
	37	55	75	90	115	130	140	160	190
3:1	0.178	0.39	0.98	2.42	7.12	14.03	26.96	52.32	91.47
4:1	0.14	0.30	0.73	1.77	5.09	9.17	17.44	32.78	62.43
5:1	0.123	0.23	0.58	1.41	4.00	7.12	13.53	24.76	44.29
6:1	0.113	0.22	0.52	1.41	3.65	6.76	12.25	22.49	39.55
8:1	0.104	0.17	0.43	1.12	2.85	5.09	8.95	15.67	27.07
10:1	0.099	0.15	0.38	1.00	2.46	4.27	7.38	12.47	21.43
12:1	0.097	0.14	0.36	0.88	2.25	3.81	6.47	10.67	18.14
15:1	0.095	0.13	0.34	0.81	2.07	3.45	5.76	9.23	15.53
16:1	-	0.40	1.19	1.25	5.12	5.37	8.74	9.70	11.55
18:1	-	0.46	1.38	1.41	6.64	6.73	12.57	12.85	13.33
24:1	-	0.39	1.15	1.18	4.9	4.99	7.99	8.27	8.75
30:1	-	0.37	1.06	1.09	4.15	4.24	6.58	6.86	7.34
32:1	-	0.38	1.15	1.16	4.84	4.88	7.79	7.89	8.07
40:1	-	0.36	1.06	1.07	4.09	4.13	6.38	6.48	6.66
50:1	-	0.36	1.05	1.06	4.07	4.09	6.31	6.36	6.45
60:1	-	0.35	0.94	0.97	3.20	3.29	4.14	4.42	4.90
80:1	-	0.34	0.94	0.95	3.14	3.18	3.94	4.04	4.22
100:1	-	0.34	0.93	0.94	3.12	3.14	3.87	3.92	4.01

## Units and Symbols

Maximum Motor Acceleration Torque	T1BMot	Nm
Nominal Output Torque	T2N	Nm
Maximum Acceleration Torque	T2B	Nm
Emergency Stop Torque	T2Not	Nm
Nominal Input Speed	n1N	rpm
Maximum Input Speed	n1max	rpm
Maximum Input Radial Load	F1Rmax	N
Maximum Output Radial Load	F2Rmax	N
Maximum Input Axial Load	F1Amax	N
Maximum Output Axial Load	F2Amax	N
Mass Moment of Inertia	I1	kgcm <sup>2</sup>
Efficiency at Full Load	η	%
Torsional Rigidity	Ct21	Nm/arc-min
Maximum Torsional Backlash	jt	arc-min
Noise Level	LpA	dB(A)
Service Life	Lh	h
Run time	RT	min
Duty cycle	DC	%
Ambient Temperature	ta	°C
Thermal Performance Limit	Ptherm	kW
Performance	P	kW
Weight	m	kg

## Dimensions and Configurations

### Base Output Dimensions

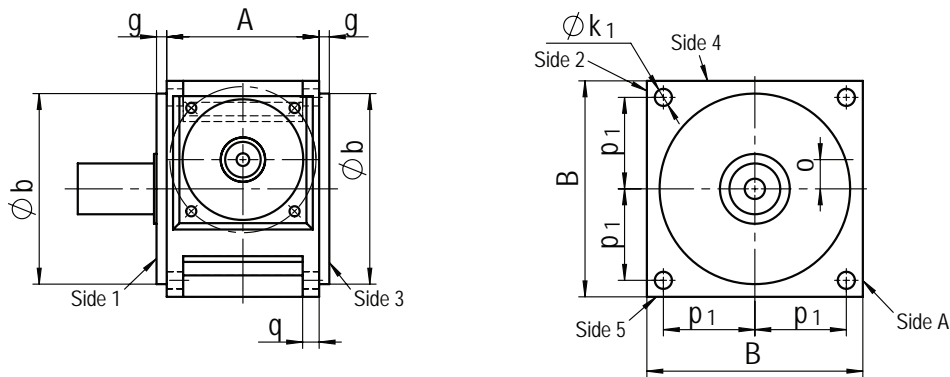

Frame Size	A	B	Ø b g6	g	o	p1	p2	Ø k1	k2	q
37	56	75	74	11	7.5	31	21	6.6	M6	-
55	60	90	89	13.5	9	39	22	6.6	M6	8
75	80	115	105	8.5	14	49	27	9	M8	10
90	100	140	125	8	18	59	33	11	M10	11
115	120	170	150	8	23	72	40	13.5	M12	13
130	138	192	173	10	27	82	48	13.5	M12	14
140	146	215	195	10	32	91	52	17.5	M16	15
160	166	240	225	10	38	103	60	17.5	M16	16
190	196	260	245	10	42	112	70	17.5	M16	17

### Base Input Dimensions

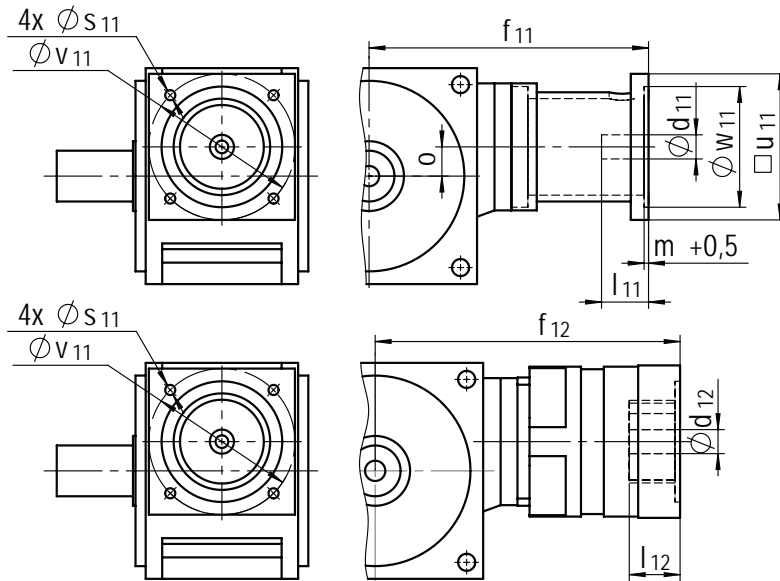

Frame Size	Single Stage					Two Stage				
	Ø d11 x l11		□ u x f11			Ø d12 x l12 x f12				
37	9x23	11x26	-	55x127.5	70x127.5	-	-	-	-	-
55	9x23	11x26	14x30	55x130	75x140	-	9x25x158.1	11x25x158.1	14x30x168.1	-
75	11x26	14x30	19x40	75x168	90x168	90x180	14x30x198.1	16x30x198.1	19x40x198.6	24x50x206.6
90	14x30	19x40	24x50	90x191	115x191	115x201	14x30x214.1	16x30x214.1	19x40x214.1	24x50x222.6
115	19x40	24x50	32x60	115x220	140x220	140x235	19x40x246.5	24x50x255.5	32x60x255.5	-
130	24x50	32x60	38x80	140x245	190x245	190x260	19x40x263.5	24x50x272.5	32x60x272.5	-
140	24x50	32x60	38x80	140x260	190x260	190x280	24x50x297.8	32x60x302.8	38x80x322.8	-
160	32x60	38x80	48x80	140x298	190x308	260x308	24x50x317.8	32x60x322.8	38x80x342.8	-
190	32x60	38x80	48x80	190x335	260x345	-	24x50x336.8	32x60x341.8	38x80x361.8	-

\* Above input dimensions are for reference only and depend on motor dimensions. Contact us to configure the appropriate adaptation for your specific motor.

## Dimensions and Configurations

### Solid Output Shaft

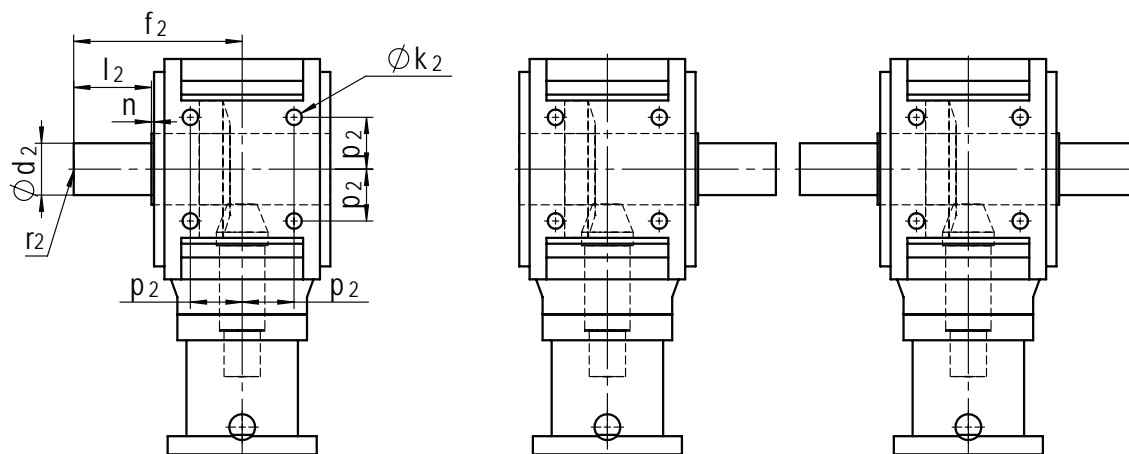

Shaft Arrangement 1L

Shaft Arrangement 3L

Shaft Arrangement 13L

Frame Size	Ø d2 k6	l2	f2	n	r2
37	16	25	65	1	M5
55	20	35	80	1.5	M6
75	24	40	90	1.5	M8
90	32	50	110	2	M12
115	40	60	130	2	M16
130	48	75	156	2	M16
140	55	90	175	2	M20
160	60	100	195	2	M20
190	70	110	220	2	M20

### Hollow Output Shaft

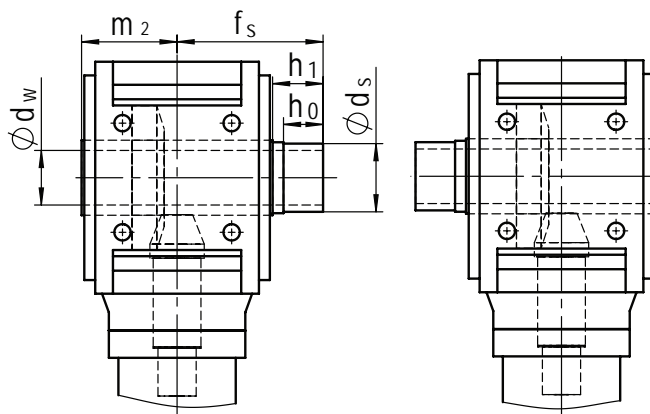

Shaft Arrangement 1LSV

Shaft Arrangement 3LSV

Frame Size	Ø dw H7	Ø ds f7	h0	h1	fs	m2
37	16	20	20	25	66	40
55	20	24	20	25	71.5	45
75	25	30	22	27	79.5	50
90	30	36	26	31	93	60
115	40	50	29	34	107	70
130	48	55	32	37	121	81
140	55	68	32	38	127	85
160	60	75	34	41	139	95
190	70	80	34	41	159	110

\*1 Hollow output shaft arrangements 1LSV/3LSV include extended shaft for shrink disc. Shrink disc sold separately.

## Dimensions and Configurations

### ISO9409-1 Robot Flange with Hollow Shaft

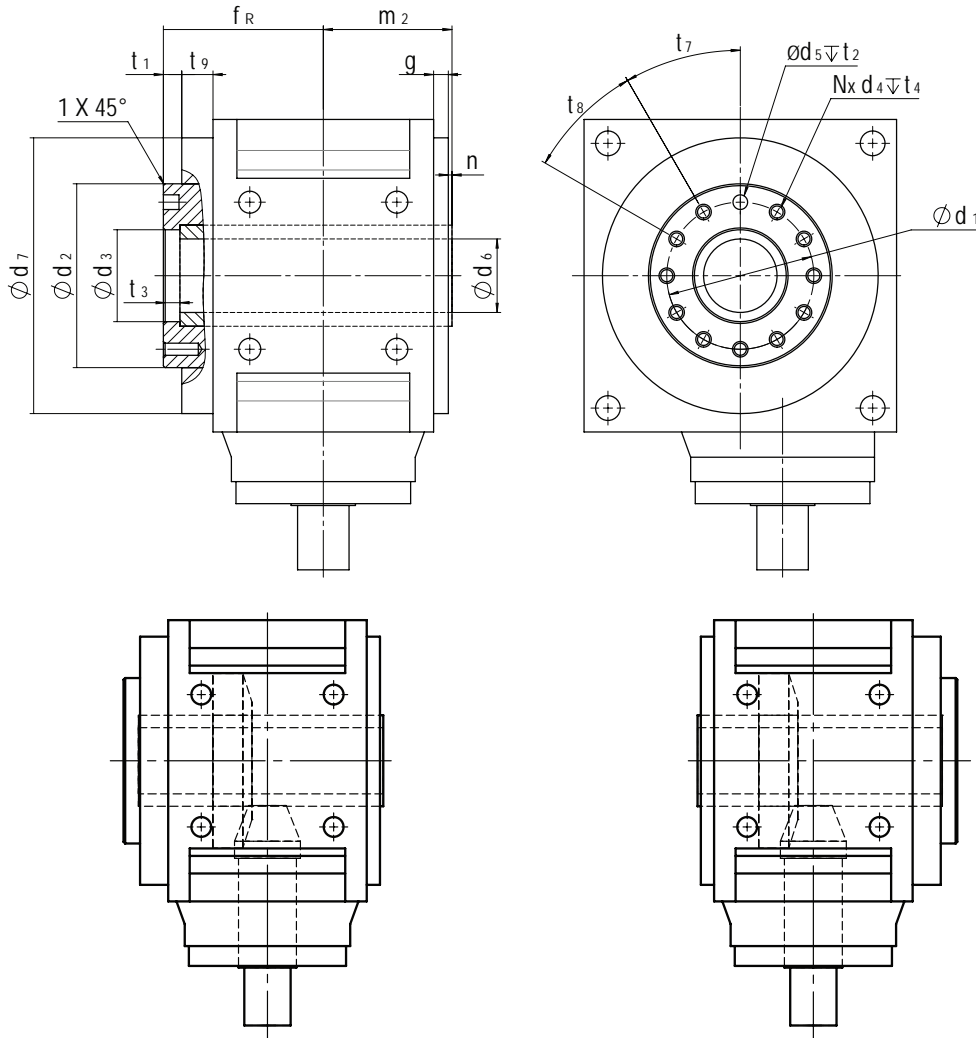

Shaft Arrangement 1RFH

Shaft Arrangement 3RFH

Frame Size	Ø d1	Ø d2 h8	Ø d3H7	d4	Ø d5H7	Ø d6	Ø d7	fR	m2
55	40	50	25	M6	6	18	89	57	45
75	50	63	31.5	M6	6	24	105	62.5	50
90	63	80	40	M6	6	28	125	73	60
115	80	100	50	M8	8	40	150	87	70
130	80	100	50	M8	8	40	173	96.5	81
140	100	125	63	M8	8	52	195	100.5	85
160	100	125	63	M8	8	52	225	115	95
190	125	160	80	M10	10	65	245	132.5	110

Frame Size	g	n	t1	t2	t3	t4	t7	t8	t9	N
55	13.5	1.5	7	6.5	7	>1.5 x d4	45°	45°	20	7
75	8.5	1.5	7	6.5	7	>1.5 x d4	45°	45°	15.5	7
90	8	2	7	6.5	7	>1.5 x d4	45°	45°	16	7
115	8	2	10	8.5	8.5	>1.5 x d4	30°	30°	17	11
130	10	2	10	8.5	8.5	>1.5 x d4	30°	30°	17.5	11
140	10	2	10	8.5	8.5	>1.5 x d4	30°	30°	17.5	11
160	10	2	12	8.5	8.5	>1.5 x d4	30°	30°	20	11
190	10	2	12	10.5	8.5	>1.5 x d4	30°	30°	22.5	11





# DYNAGEAR ECO SERIES

DynaGear Eco is a cost-optimized right-angle hypoid solution that performs well in dynamic servo applications requiring low torsional backlash and high efficiency in a compact footprint. DynaGear Eco uses optimized hypoid gears for high torque transfer and backlash down to < 6 arc-min. Tapered roller bearings on the input and output sides of the gearbox absorb high radial and axial loads, ensuring long service life.

DynaGear Eco comes in three frame sizes which use a weight efficient one-piece aluminum housing for high stability under load. Output mounting options include solid and hollow shaft, utilizing industry standard dimensions. Its compact design provides significant space savings for small installation envelopes. Lubricated for life, DynaGear Eco is a reliable maintenance-free solution.

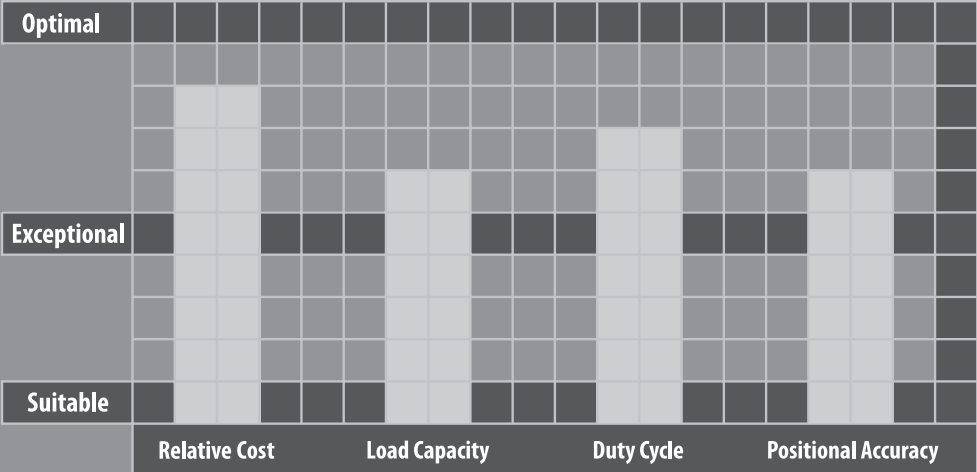

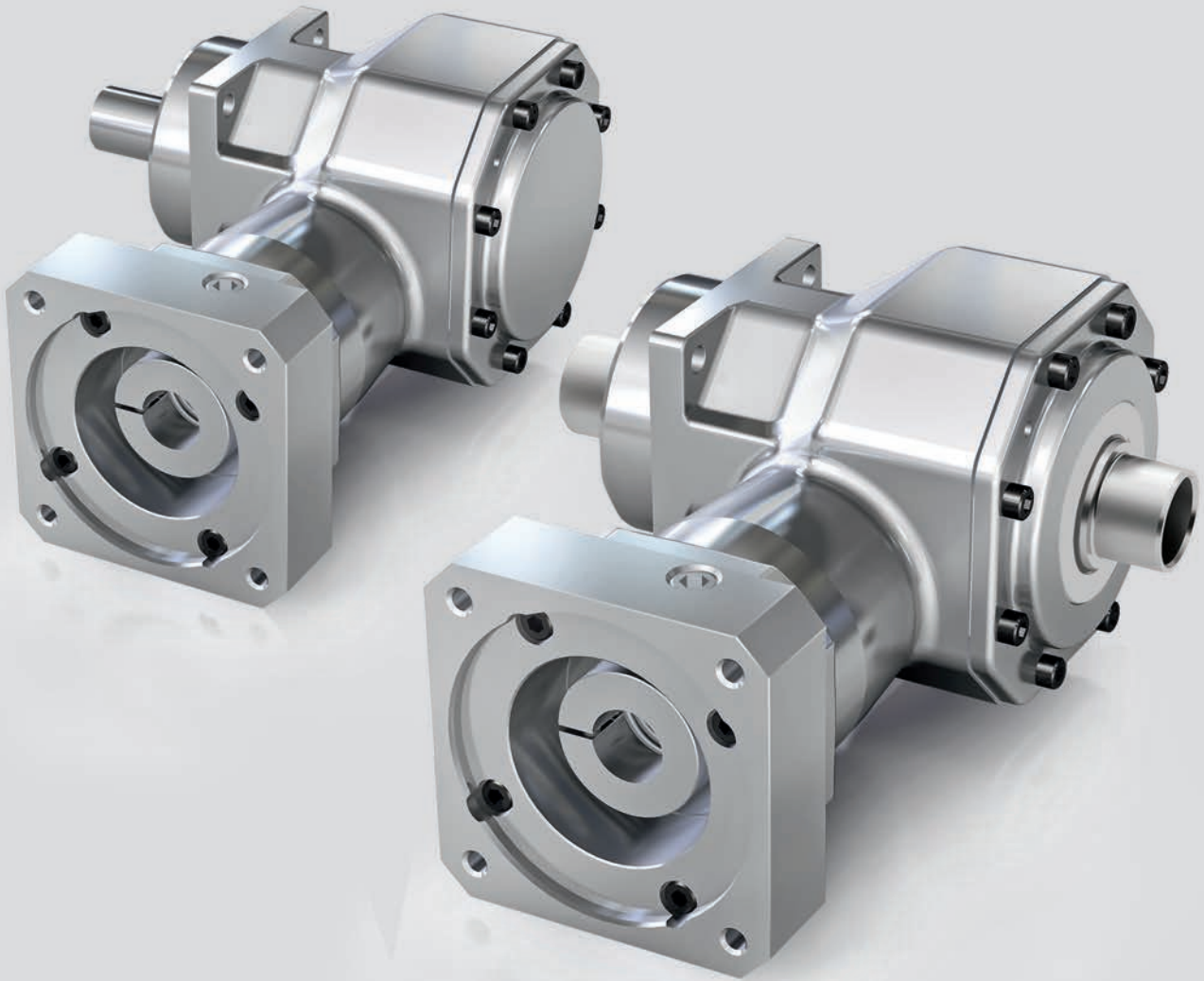

## DYNAGEAR ECO SERIES

- Highest quality hypoid gearing with optimized contact pattern combines the space and configuration advantages of worm gearing with the high efficiencies of bevel gearing
- Cost-effective design with low backlash (<6 arc-min), high torsional stiffness, smooth torque transmission and negligible noise. Efficiency as high as 96%
- Solid or hollow output shaft with shrink disc. Industry standard mounting dimensions for easy changeout in existing applications
- Compact, rigid, weight efficient design
- Maintenance-free solution that is lubricated for life
- Assembled in Germany

## Featured Highlights

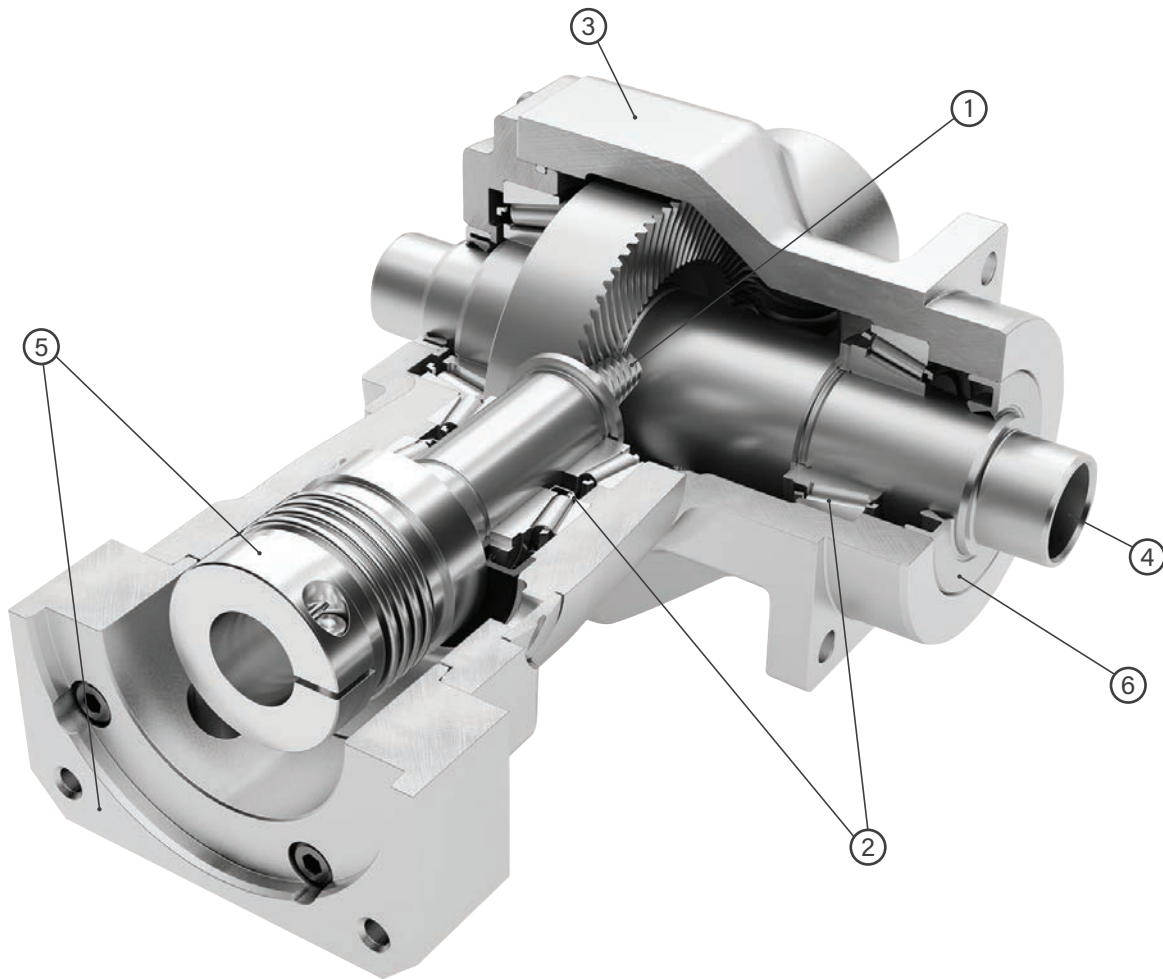

- ① Hypoid gearing with optimized contact pattern for uniform load distribution
- ② Tapered roller bearings at input and output for high radial and axial load capacity
- ③ Weight efficient one-piece aluminum housing ensuring high stability under load
- ④ Solid or hollow output shaft with optional shrink disc
- ⑤ Simple, low inertia connection to various servo motors using adapter flange and stiff zero backlash coupling
- ⑥ Output seal allows for IP64 protection

## Model Code

<b>DE-PL</b>	—	<b>75</b>	—	<b>8</b>	—	<b>XXX</b>
Series Name		Frame Size		Ratio		*Motor Mounting Code
<b>DE-PL:</b> Solid Output Shaft <b>DE-PLH:</b> Hollow Output Shaft		55 75 90		5 8 10 15		Motor mounting code varies depending on the motor

\* Motor mounting code varies depending on the motor. Contact us to configure the code.

## Performance Specifications

Frame Size	Units	Note	55	75	90	55	75	90
<b>Ratio</b>	i		5/8/10			15		
Nominal Output Torque	T2N [Nm]	*1	35	70	140	25	50	95
Maximum Acceleration Torque	T2B [Nm]	*2	53	105	210	38	75	143
Emergency Stop Torque	T2Not [Nm]	*3	70	140	280	50	100	190
Nominal Input Speed (Ratios 5/8)	n1N [rpm]	*4	3100	2400	2100	-	-	-
Nominal Input Speed (Ratios 10/15)	n1N [rpm]	*4	3800	2900	2600	3800	2900	2600
Maximum Input Speed	n1max [rpm]	*5	6000	6000	5000	6000	6000	5000
Maximum Radial Load	F2Rmax [N]	*6	2200	4050	6200	2200	4050	6200
Maximum Axial Load	F2Amax [N]	*7	1100	2025	3100	1100	2025	3100
Moment of Inertia (Ratio 5)	[kgcm <sup>2</sup> ]	-	0.44	1.07	3.70	-	-	-
Moment of Inertia (Ratio 8)	[kgcm <sup>2</sup> ]	-	0.37	0.89	3.00	-	-	-
Moment of Inertia (Ratio 10)	[kgcm <sup>2</sup> ]	-	0.35	0.84	2.90	-	-	-
Moment of Inertia (Ratio 15)	[kgcm <sup>2</sup> ]	-	-	-	-	0.33	0.79	2.70
Efficiency	h [%]	*8	> 96	> 96	> 96	> 93	> 93	> 93
Torsional Rigidity	Ct21 [Nm/arcmin]	*9	2.5	5	12	2.5	5	12
Maximum Torsional Backlash	jt [arcmin]	*10	≤ 7	≤ 7	≤ 6	≤ 7	≤ 7	≤ 6
Noise Level	LpA [dB(A)]	*11	< 66	< 66	< 68	< 66	< 66	< 68
Ambient Temperature	[°C]	-	-10 to 90					
Permitted Housing Temperature	[°C]	-	90					
Protection Class	-	-	IP64					
Lubrication	-	-	Synthetic Oil [ISO VG-Class 150]					
Service Life	SL [h]	*12	15,000					
Weight	m [kg]	-	2.6	4.5	9.0	2.6	4.5	9.0

\*1 At nominal input speed, service life is 15,000 hours.

\*2 The maximum torque when starting or stopping operation. Permitted 1,000 cycles/hour.

\*3 The maximum torque allowed under a stress situation. Permitted 1,000 times during service life.

\*4 The average input speed at nominal input torque. Maintain housing temperature below permitted value.

\*5 The maximum intermittent input speed.

\*6 The maximum radial load the gearbox can accept. Measured at center of output shaft at 400rpm output.

\*7 The maximum axial load the gearbox can accept. Measured at center of output shaft at 400rpm output.

\*8 The efficiency at full load.

\*9 At nominal output torque. Does not include lost motion.

\*10 Measured at output, 2% load and max 10Nm.

\*11 Measured at 3,000 rpm input.

\*12 Based on S5 duty cycle <60% and <20 minute run time.

## Units and Symbols

Maximum Motor Acceleration Torque	T1BMot	Nm
Nominal Output Torque	T2N	Nm
Maximum Acceleration Torque	T2B	Nm
Emergency Stop Torque	T2Not	Nm
Nominal Input Speed	n1N	rpm
Maximum Input Speed	n1max	rpm
Maximum Input Radial Load	F1Rmax	N
Maximum Output Radial Load	F2Rmax	N
Maximum Input Axial Load	F1Amax	N
Maximum Output Axial Load	F2Amax	N
Mass Moment of Inertia	I1	kgcm <sup>2</sup>
Efficiency at Full Load	η	%
Torsional Rigidity	Ct21	Nm/arc-min
Maximum Torsional Backlash	jt	arc-min
Noise Level	LpA	dB(A)
Service Life	Lh	h
Run time	RT	min
Duty cycle	DC	%
Ambient Temperature	ta	°C
Thermal Performance Limit	Ptherm	kW
Performance	P	kW
Weight	m	kg



## Dimensions and Configurations

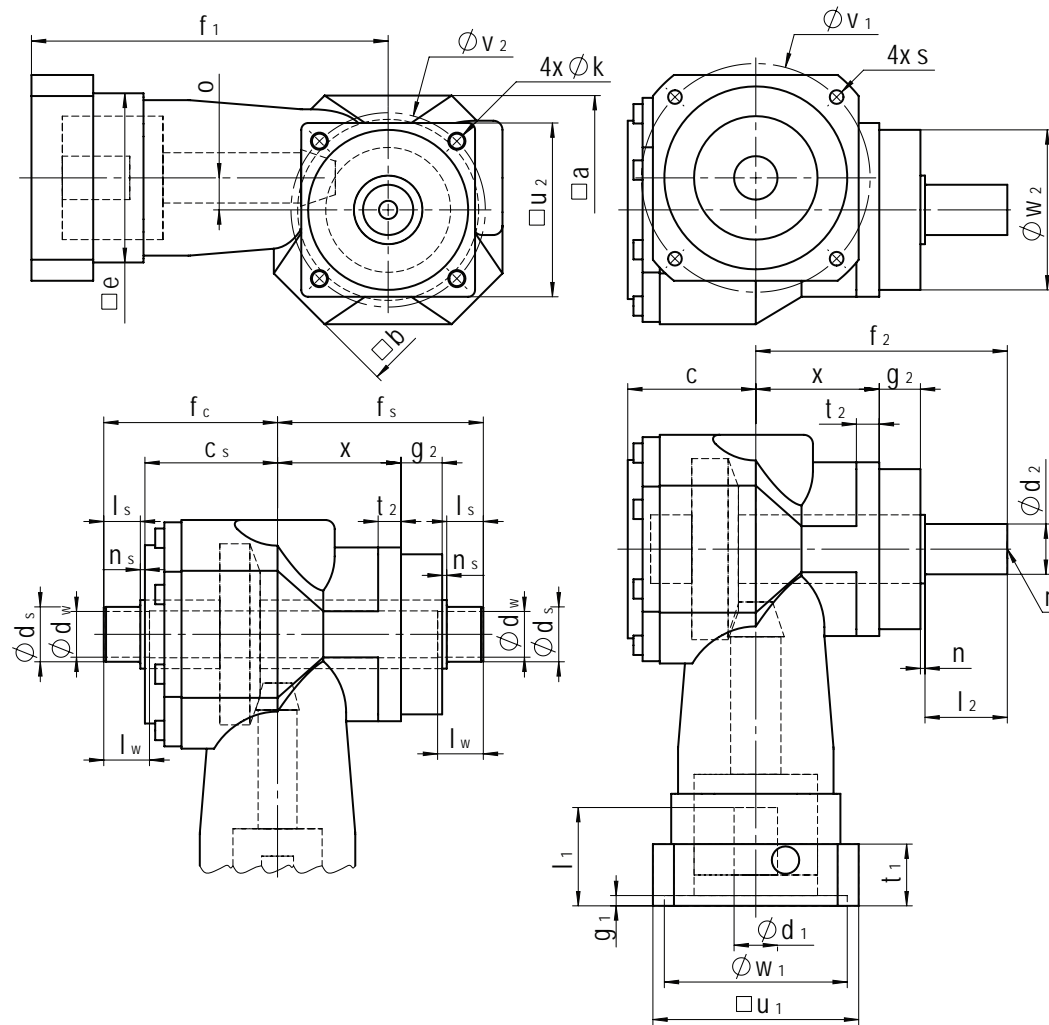

### Base Dimensions

Frame Size	$\square a$	$\square b$	$x$	$o$	$\square e$	$f_1$	$g_1$	$t_1$	$g_2$	$t_2$	$\phi k$	$\square u_2$	$\phi V_2$	$\phi w_2 g_6$
55	84	91.5	47	9	58	130	4.5	20	18	8.5	5.5	66	68	60
75	100	110	54	14	74	156	4.5	27	18	10	6.5	76	85	70
90	125	139	68	18	89	187	4.5	33	20	13	9	101	120	90

### Input Dimensions

Frame Size	$\phi d_1$	$l_1$	$\square u_1$	$\phi V_1$	$\phi w_1 F_7$	$s$
55	9	23	60	63	40	M4
	11	26	75	75	60	M5
	14	33	75	75	60	M5
75	11	26	75	75	60	M5
	14	33	75	75	60	M5
	19	43	90	100	80	M6
90	14	33	90	100	80	M6
	19	43	90	100	80	M6
	24	53	115	130	110	M8

### Solid Output Dimensions

Frame Size	$\phi d_2 k_6$	$l_2$	$f_2$	$n$	$r$	$c$
55	16	28	95	2	M5	46.5
75	22	36	110	2	M8	56
90	32	58	148	2	M12	68

### Hollow Output Dimensions

Frame Size	$\phi d_w H_6$	$\phi d_s h_8$	$l_s$	$n_s$	$l_w$	$f_s$	$f_c$	$c_s$
55	15	18	14	2	18	81	65.5	49.5
75	20	24	16	2	20	90	76	58
90	30	36	20	2	25	110	90.5	68.5

\* Above input dimensions are for reference only and depend on motor dimensions.  
Contact us to configure the appropriate adaptation for your specific motor.

# EVOGEAR SERIES

**E**voGear is the next generation of hypoid gearing performance. It confidently combines the efficiency and compactness of a hypoid primary stage with the torque density and low backlash of the VRS and VRT planetary products. Tapered roller bearings on the input and output side of the gearbox absorb high radial and axial loads, ensuring long service life. A planetary output is used to achieve very high ratios.

EvoGear comes in four different output configurations and 17 reduction ratios to allow for use in a vast array of applications. Ratios up to 15:1 are available in a single stage, making it a compact design for small installation envelopes. Lubricated for life, EvoGear is a reliable maintenance-free solution.

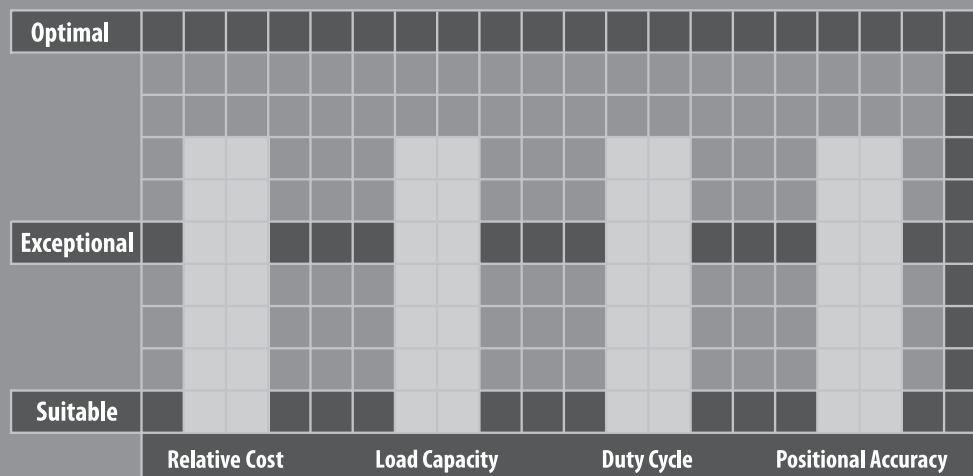

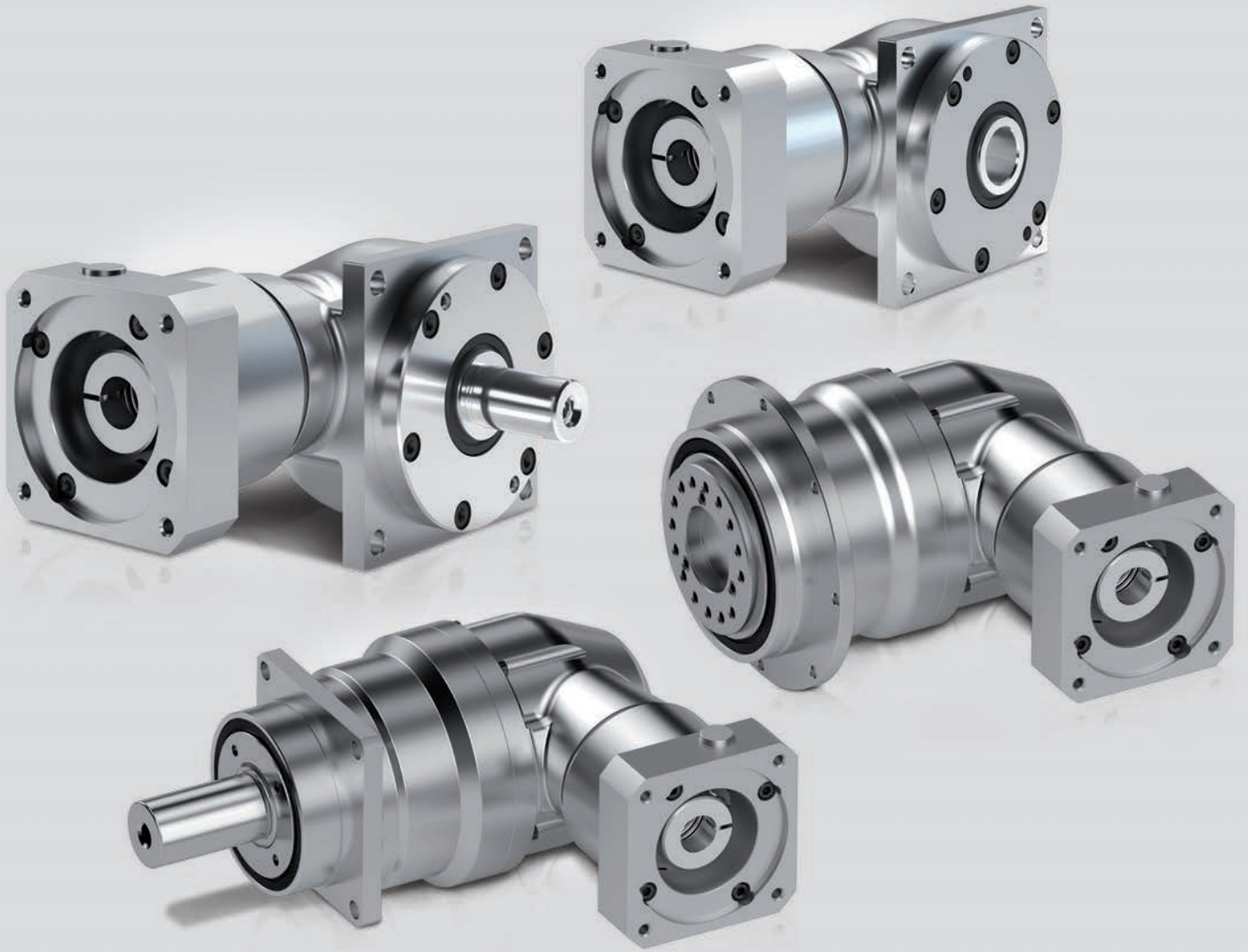

## EVOGEAR SERIES

- New generation of right-angle products that combine the efficiency and compactness of a hypoid primary stage with the torque density and low backlash of the VRS and VRT planetary outputs
- Low backlash (down to  $<4$  arc-min), high torsional stiffness, smooth torque transmission and negligible noise. Efficiency as high as 96%
- 4 Frame sizes, 17 reduction ratios and 4 output mounting configurations
- Compact, rigid, weight efficient design
- Maintenance-free solution that is lubricated for life
- Assembled in Germany

## Featured Highlights

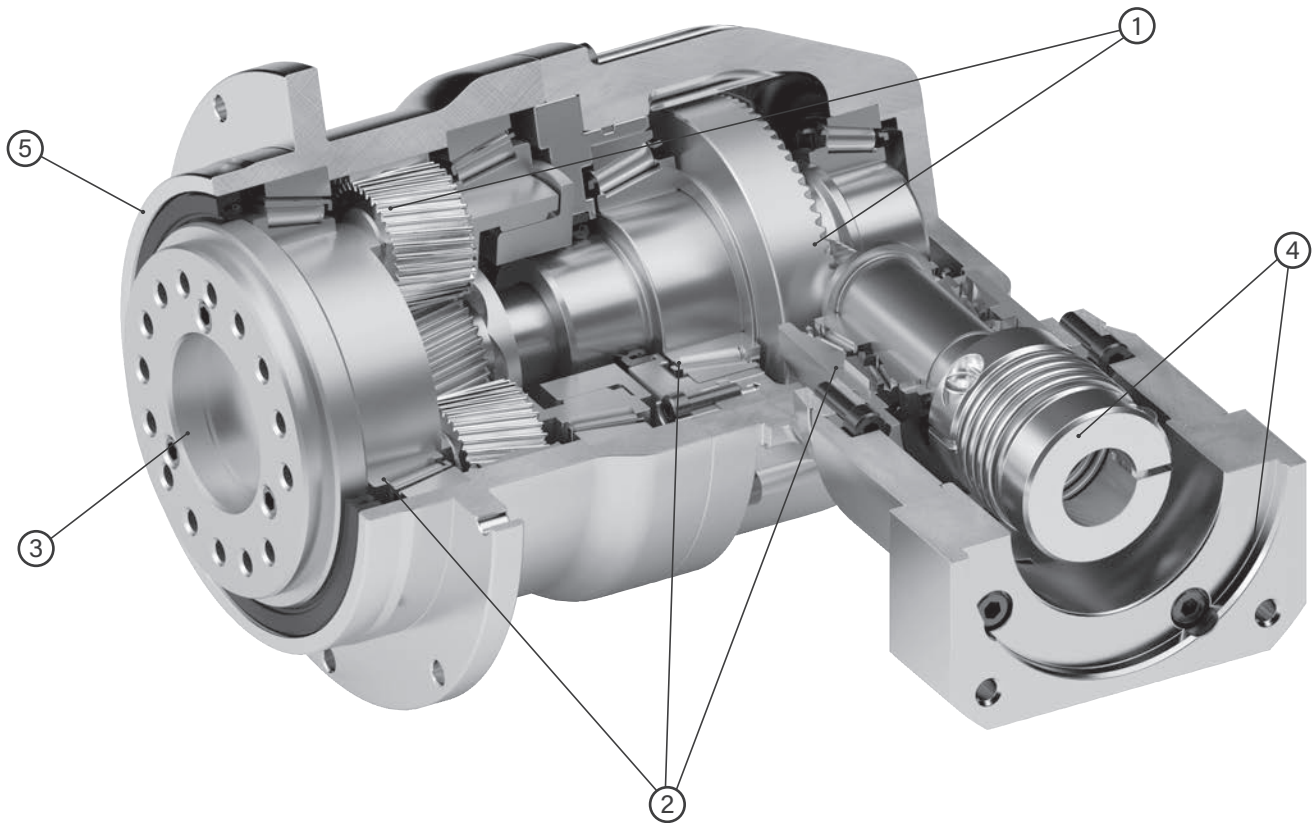

- ① Hypoid input stage with optional planetary output stage. Planetary section includes carburized case-hardened helical gears with proprietary secondary finishing process for higher accuracy and smooth, quiet operation
- ② Tapered roller bearings at input and output stages for high radial, axial and tilting moment load capacity
- ③ Three output mounting styles for maximum flexibility: Solid shaft, hollow shaft, ISO 9409-1 robot flange. Industry standard dimensional compatibility
- ④ Simple, concentric, low inertia connection to various servo motors using adapter flange and stiff zero backlash coupling. Ready for dynamic or high-speed applications
- ⑤ Output seal allows for IP64 protection

## Model Code

<b>EG</b>	<b>75</b>	<b>10</b>	<b>PLT</b>	<b>XXX</b>
Series Name	Frame Size	Ratio	Output Mounting Type	*Motor Mounting Code
EG EvoGear	55 75 90 115	3 4 5 6 8 10 12 15 16 20 25 28 35 40 50 70 100	L: Solid Shaft LSV: Hollow Shaft PLS: Planetary Solid Shaft PLT: Planetary Robot Flange	Motor mounting code varies depending on the motor

\* Motor mounting code varies depending on the motor. Contact us to configure the code.



## Performance Specifications

### Solid and Hollow Shaft - L, LSV Configurations

Frame Size	Units	Note	55	75	90	115	55	75	90	115
Ratio	i		3/4/5/6/8/10				12/15			
Nominal Output Torque	T2N [Nm]	*1	35	70	140	260	25	50	95	180
Maximum Acceleration Torque	T2B [Nm]	*2	53	105	210	390	38	75	143	270
Emergency Stop Torque	T2Not [Nm]	*3	70	140	280	520	50	100	190	360
Nominal Input Speed	n1N [rpm]	*4	3100	2400	2100	1820	3800	2900	2600	2250
Maximum Input Speed	n1max [rpm]	*5	6000	6000	5000	4000	6000	6000	5000	4000
Maximum Radial Load	F2Rmax [N]	*6	3300	4900	7200	10000	3300	4900	7200	10000
Maximum Axial Load	F2Amax [N]	*7	2650	2450	3600	5000	1650	2450	3600	5000
Moment of Inertia (Ratio 3)	[kgcm <sup>2</sup> ]	-	0.376	0.958	2.35	6.82	-	-	-	-
Moment of Inertia (Ratio 4)	[kgcm <sup>2</sup> ]	-	0.275	0.715	1.73	4.92	-	-	-	-
Moment of Inertia (Ratio 5)	[kgcm <sup>2</sup> ]	-	0.224	0.577	1.41	3.84	-	-	-	-
Moment of Inertia (Ratio 6)	[kgcm <sup>2</sup> ]	-	0.217	0.529	1.42	3.62	-	-	-	-
Moment of Inertia (Ratio 8)	[kgcm <sup>2</sup> ]	-	0.177	0.440	1.13	2.84	-	-	-	-
Moment of Inertia (Ratio 10)	[kgcm <sup>2</sup> ]	-	0.157	0.396	0.99	2.47	-	-	-	-
Moment of Inertia (Ratio 12)	[kgcm <sup>2</sup> ]	-	-	-	-	-	0.146	0.366	0.91	2.27
Moment of Inertia (Ratio 15)	[kgcm <sup>2</sup> ]	-	-	-	-	-	0.135	0.345	0.85	2.10
Efficiency	h [%]	*8	> 96	> 96	> 96	> 96	> 93	> 93	> 93	> 93
Torsional Rigidity	Ct21 [Nm/arcmin]	*9	2.1	4.2	10.5	23.4	2.1	4.2	10.5	23.4
Maximum Torsional Backlash	jt [arcmin]	*10	≤ 6	≤ 5	≤ 5	≤ 4	≤ 4	≤ 4	≤ 4	≤ 4
Noise Level	LpA [dB(A)]	*11	< 66	< 66	< 68	< 68	< 66	< 66	< 68	< 68
Ambient Temperature	[°C]	-	-10 to 90							
Permitted Housing Temperature	[°C]	-	90							
Protection Class	-	-	IP64							
Lubrication	-	-	Synthetic Oil [ISO VG-Class 150]							
Service Life	SL [h]	*12	30,000							
Weight	m [kg]	-	2.9	4.8	8.6	13.3	2.9	4.8	8.6	13.3

\*1 At nominal input speed, service life is 30,000 hours.

\*2 The maximum torque when starting or stopping operation. Permitted 1,000 cycles/hour.

\*3 The maximum torque allowed under a stress situation. Permitted 1,000 times during service life.

\*4 The average input speed at nominal input torque. Maintain housing temperature below permitted value.

\*5 The maximum intermittent input speed.

\*6 The maximum radial load the gearbox can accept. Measured at center of output shaft at 400rpm output.

\*7 The maximum axial load the gearbox can accept. Measured at center of output shaft at 400rpm output.

\*8 The efficiency at full load.

\*9 At nominal output torque. Does not include lost motion.

\*10 Measured at output, 2% load and max 10Nm.

\*11 Measured at 3,000 rpm input.

\*12 Based on S5 duty cycle <60% and <20 minute run time.

## Units and Symbols

Maximum Motor Acceleration Torque	T1BMot	Nm
Nominal Output Torque	T2N	Nm
Maximum Acceleration Torque	T2B	Nm
Emergency Stop Torque	T2Not	Nm
Nominal Input Speed	n1N	rpm
Maximum Input Speed	n1max	rpm
Maximum Input Radial Load	F1Rmax	N
Maximum Output Radial Load	F2Rmax	N
Maximum Input Axial Load	F1Amax	N
Maximum Output Axial Load	F2Amax	N
Mass Moment of Inertia	I1	kgcm <sup>2</sup>
Efficiency at Full Load	η	%
Torsional Rigidity	Ct21	Nm/arc-min
Maximum Torsional Backlash	jt	arc-min
Noise Level	LpA	dB(A)
Service Life	Lh	h
Run time	RT	min
Duty cycle	DC	%
Ambient Temperature	ta	°C
Thermal Performance Limit	Ptherm	kW
Performance	P	kW
Weight	m	kg

## Performance Specifications

### Planetary Solid Shaft and Robot Flange - PLS, PLT Configurations

Frame Size	Units	Note	Ratio	55	75	90	115
Nominal Output Torque	T2N [Nm]	*1	16	80	200	380	850
Maximum Acceleration Torque	T2B [Nm]	*2		165	390	840	1850
Emergency Stop Torque	T2Not [Nm]	*3		250	625	1250	2750
Nominal Output Torque	T2N [Nm]	*1	20	86	220	410	910
Maximum Acceleration Torque	T2B [Nm]	*2		165	390	840	1850
Emergency Stop Torque	T2Not [Nm]	*3		250	625	1250	2750
Nominal Output Torque	T2N [Nm]	*1	25	106	280	590	1100
Maximum Acceleration Torque	T2B [Nm]	*2		165	390	840	1850
Emergency Stop Torque	T2Not [Nm]	*3		250	625	1250	2750
Nominal Output Torque	T2N [Nm]	*1	28/35/40/50/70	118	280	590	1300
Maximum Acceleration Torque	T2B [Nm]	*2		165	390	840	1850
Emergency Stop Torque	T2Not [Nm]	*3		250	625	1250	2750
Nominal Output Torque	T2N [Nm]	*1	100	88	220	440	930
Maximum Acceleration Torque	T2B [Nm]	*2		112	292	610	1350
Emergency Stop Torque	T2Not [Nm]	*3		200	500	1000	2200
Nominal Input Speed	n1N [rpm]	*4	16-100	2700	2700	2600	2100
Maximum Input Speed	n1max [rpm]	*5	16-100	8000	8000	7000	6000
Maximum Radial Load (PLS)	F2Rmax [N]	*6	16-100	4300	7000	10000	19000
Maximum Axial Load (PLS)	F2Amax [N]	*7	16-100	3900	6300	9000	17000
Maximum Radial Load (PLT)	F2Rmax [N]	*6	16-100	3300	12000	19000	40000
Maximum Axial Load (PLT)	F2Amax [N]	*7	16-100	1700	8800	14000	30000
Moment of Inertia (PLS)	[kgcm <sup>2</sup> ]	-	16	0.302	0.829	2.20	6.43
	[kgcm <sup>2</sup> ]	-	20	0.241	0.649	1.71	4.81
	[kgcm <sup>2</sup> ]	-	25	0.238	0.629	1.65	4.57
	[kgcm <sup>2</sup> ]	-	28	0.292	0.772	2.00	5.74
	[kgcm <sup>2</sup> ]	-	35	0.235	0.613	1.58	4.37
	[kgcm <sup>2</sup> ]	-	40	0.182	0.462	1.20	3.11
	[kgcm <sup>2</sup> ]	-	50	0.160	0.410	1.03	2.64
	[kgcm <sup>2</sup> ]	-	70	0.160	0.406	1.02	2.59
	[kgcm <sup>2</sup> ]	-	100	0.159	0.404	1.01	2.57
Moment of Inertia (PLT)	[kgcm <sup>2</sup> ]	-	16	0.321	0.904	2.44	8.19
	[kgcm <sup>2</sup> ]	-	20	0.253	0.698	1.86	5.93
	[kgcm <sup>2</sup> ]	-	25	0.246	0.666	1.76	5.33
	[kgcm <sup>2</sup> ]	-	28	0.298	0.804	2.09	6.38
	[kgcm <sup>2</sup> ]	-	35	0.239	0.634	1.64	4.77
	[kgcm <sup>2</sup> ]	-	40	0.185	0.476	1.24	3.41
	[kgcm <sup>2</sup> ]	-	50	0.162	0.419	1.06	2.84
	[kgcm <sup>2</sup> ]	-	70	0.161	0.411	1.03	2.70
	[kgcm <sup>2</sup> ]	-	100	0.160	0.407	1.02	2.63
Efficiency	h [%]	*8	16-100	> 94	> 94	> 94	> 94
Torsional Rigidity (PLS)	Ct21 [Nm/arcmin]	*9	16-100	10	31	60	175
Torsional Rigidity (PLT)	Ct21 [Nm/arcmin]	*9	16-100	27	64	143	430
Maximum Torsional Backlash (Standard)	jt [arcmin]	*10	16-100	≤ 5	≤ 4	≤ 4	≤ 4
Noise Level	LpA [dB(A)]	*11	16-100	< 68	< 68	< 70	< 70
Ambient Temperature	[°C]	-	-10 to 90				
Permitted Housing Temperature	[°C]	-	90				
Protection Class	-	-	IP64				
Lubrication	-	-	Synthetic Oil [ISO VG-Class 150]				
Service Life	SL [h]	*12	20,000				
Weight (PLS)	m [kg]	-	16-100	5.0	9.9	19.5	38.0
Weight (PLT)	m [kg]	-	16-100	5.2	9.7	18.0	41.0

\*1 At nominal input speed, service life is 30,000 hours.

\*2 The maximum torque when starting or stopping operation. Permitted 1,000 cycles/hour.

\*3 The maximum torque allowed under a stress situation. Permitted 1,000 times during service life.

\*4 The average input speed at nominal input torque. Maintain housing temperature below permitted value.

\*5 The maximum intermittent input speed.

\*6 The maximum radial load the gearbox can accept. Measured at center of output shaft at 400rpm output.

\*7 The maximum axial load the gearbox can accept. Measured at center of output shaft at 400rpm output.

\*8 The efficiency at full load.

\*9 At nominal output torque. Does not include lost motion.

\*10 Measured at output, 2% load and max 10Nm.

\*11 Measured at 3,000 rpm input.

\*12 Based on S5 duty cycle <60% and <20 minute run time.

## Dimensions and Configurations

Solid Shaft, Hollow Shaft, Planetary Solid Shaft - L, LSV, PLS Configurations

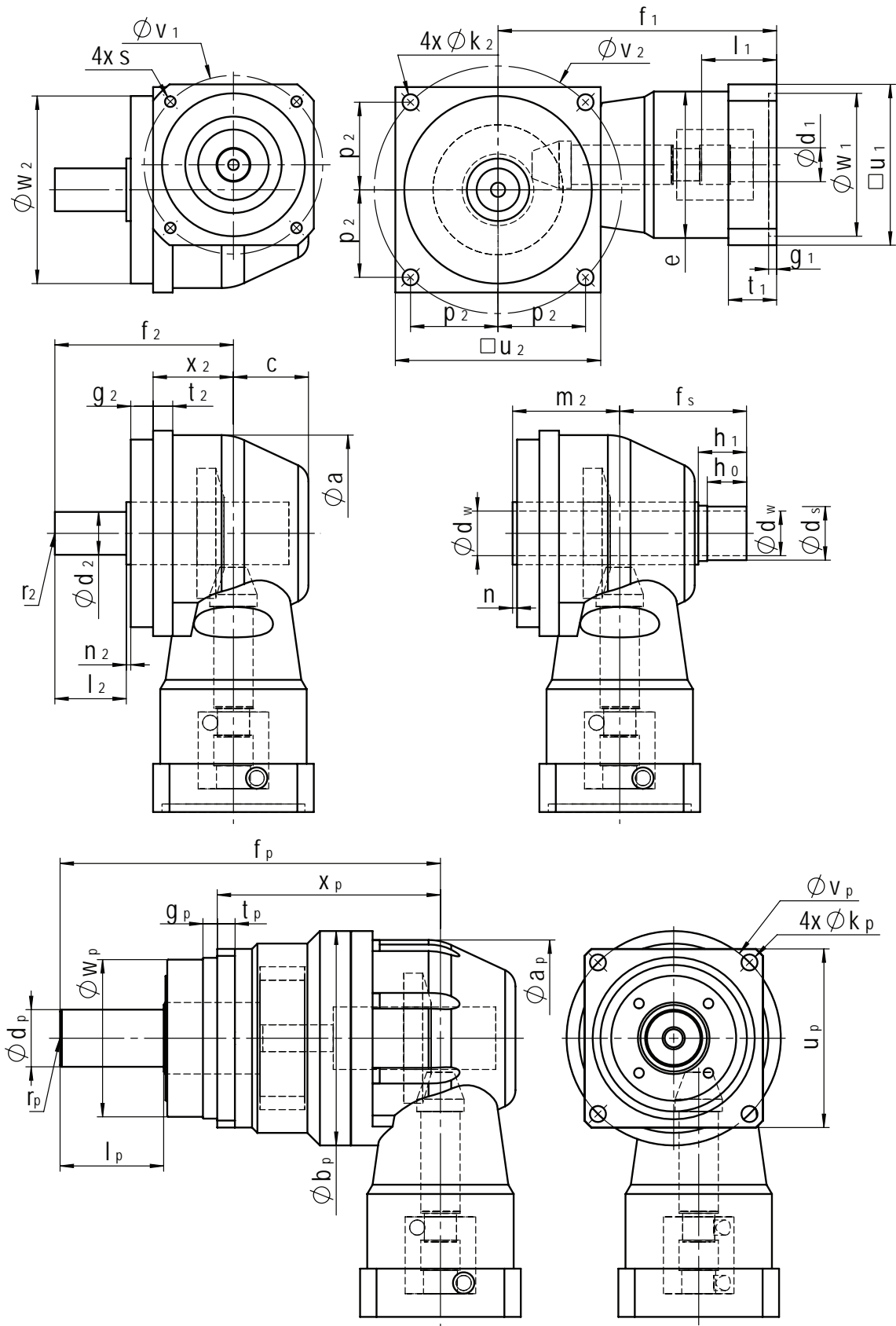

## Dimensions and Configurations

Solid Shaft, Hollow Shaft, Planetary Solid Shaft - L, LSV, PLS Configurations

### Input Dimensions

Frame Size	e	f1	g1	t1	Ød1	l1	□u1	Øv1	Øw1F7	s
55	Ø60	133	4.5	20	9	23	60	63	40	M4
					11	26	75	75	60	M5
					14	33	75	75	60	M5
75	Ø82	156	4.5	27	11	26	75	75	60	M5
					14	33	75	75	60	M5
					19	43	90	100	80	M6
90	Ø90	182	4.5	33	14	33	90	100	80	M6
					19	43	90	100	80	M6
					24	53	115	130	110	M8
115	Ø114	209.5	6.0	40	19	43	115	130	110	M8
					24	53	115	130	110	M8
					32	63	140	165	130	M10

### Solid Output Dimensions

Frame Size	Øa	c	Ød2k6	l2	f2	n2	r2	x2	g2	t2	Øk2	p2	□u2	Øv2	Øw2 g6
55	87	36	20	35	87	1.5	M6	37	13.5	9	6.6	39	90	110.3	89
75	110	42	24	40	100	2.5	M8	45	12.5	11	9	49	115	138.6	105
90	134	52	32	50	122.5	2	M12	58	12.5	14	11	59	140	166.9	125
115	162	63	40	60	149	3	M16	71	15	17	13.5	75	170	203.6	150

### Hollow Output Dimensions

Frame Size	Øa	c	ØdwH7	Ødsf7	h0	h1	fs	m2	n	x2	g2	t2	Øk2	p2	□u2	Øv2	Øw2 g6
55	87	36	20	24	20	26.5	64.5	52	1.5	37	13.5	9	6.6	39	90	110.3	89
75	110	42	25	30	22	27	71	60	2.5	45	12.5	11	9	49	115	138.6	105
90	134	52	30	36	26	33	87	72.5	2	58	12.5	14	11	59	140	166.9	125
115	162	63	40	50	29	37	102	89	3	71	15	17	13.5	75	170	203.6	150

\* Includes extended shaft for shrink disc. Shrink disc sold separately.

### Planetary Solid Output Dimensions

Frame Size	Øap	Øbp	Ødp j6	lp	fp	rp	□up	Øvp	Øwp g6	xp	tp	gp	Økp
55	89	89	22	36	167	M8	75	85	70	111	7	6	6.6
75	115	120	32	58	213	M12	100	120	90	125	10	8	9
90	142	150	40	82	263.5	M16	140	165	130	151.5	12	10	11
115	181	200	55	82	300.5	M20	180	215	160	188.5	15	12	13.5

\* Optional keyed output shaft available.

## Dimensions and Configurations

### Planetary Robot Flange - PLT Configuration

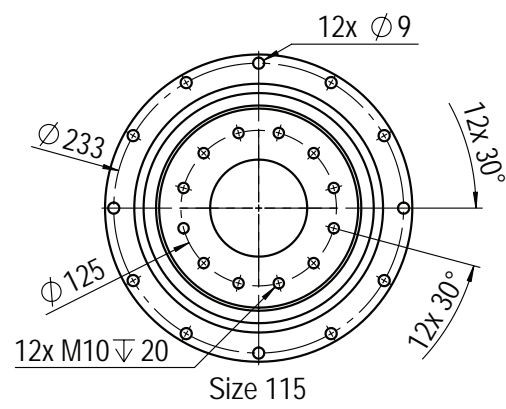
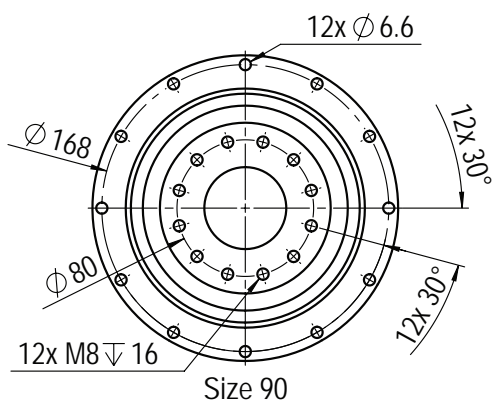
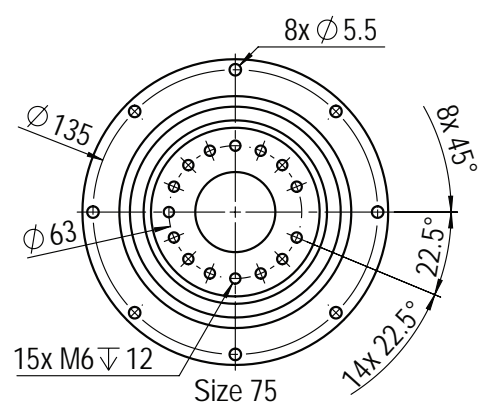
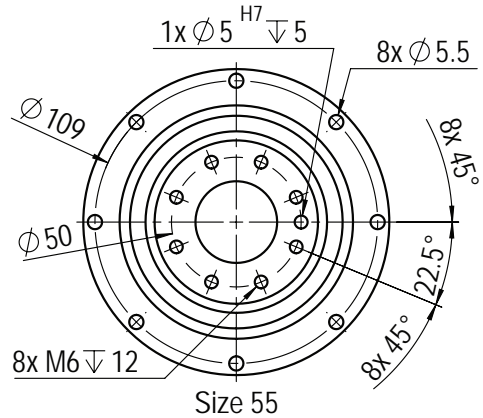
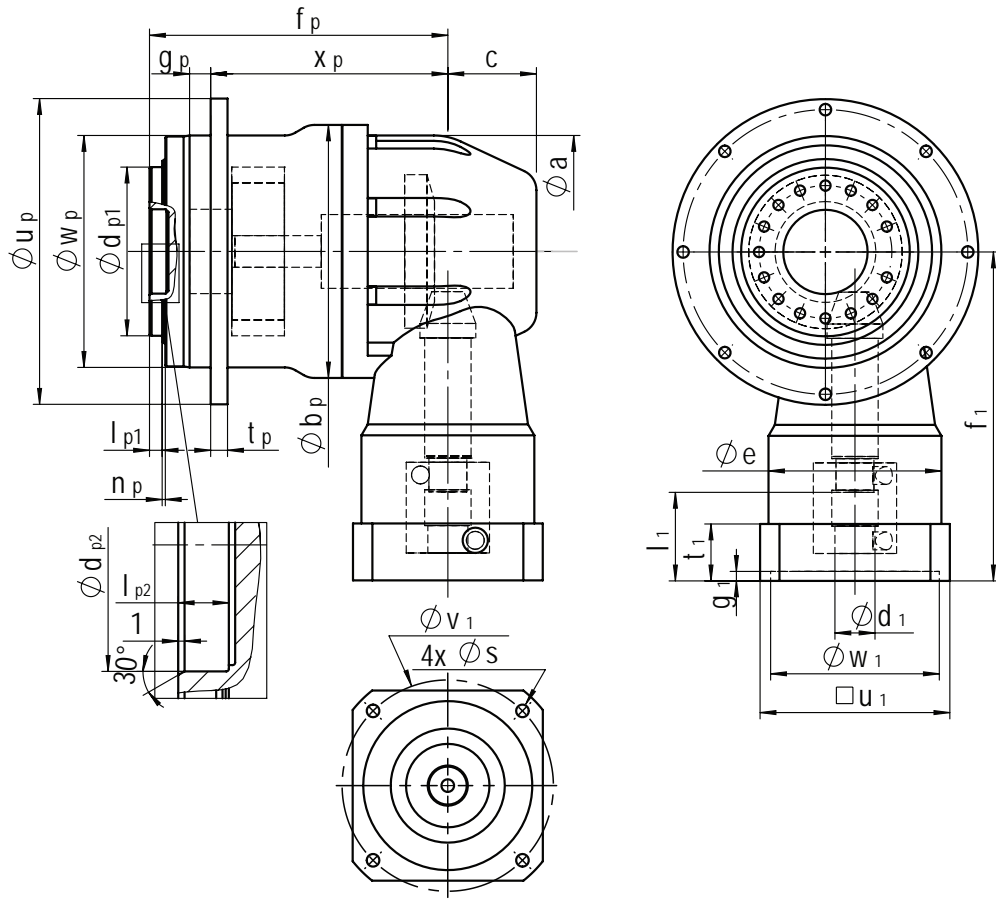

## Dimensions and Configurations

### Planetary Robot Flange - PLT Configuration

#### Input Dimensions

Frame Size	e	f1	g1	t1	Ød1	l1	□u1	Øv1	Øw1F7	s
55	Ø60	133	4.5	20	9	23	60	63	40	M4
					11	26	75	75	60	M5
					14	33	75	75	60	M5
75	Ø82	156	4.5	27	11	26	75	75	60	M5
					14	33	75	75	60	M5
					19	43	90	100	80	M6
90	Ø90	182	4.5	33	14	33	90	100	80	M6
					19	43	90	100	80	M6
					24	53	115	130	110	M8
115	Ø114	209.5	6.0	40	19	43	115	130	110	M8
					24	53	115	130	110	M8
					32	63	140	165	130	M10

#### Planetary Robot Flange Output Dimensions

Frame Size	Øa	c	xp	fp	Ødp1 h7	lp1	Ødp2F7	lp2	Øup	Øwp h7	tp	gp	Øbp
55	89	36	72.5	102.5	63	6	31.5	6	118	90	7	10	89
75	115	42	112.5	141.5	80	6	40	8	145	110	8	10	120
90	142	52	126	164	100	6	50	10	179	140	10	14	150
115	181	63	159	209	160	8	80	16	247	200	12	15	208

\* Above input dimensions are for reference only and depend on motor dimensions.  
Contact us to configure the appropriate adaptation for your specific motor.

# Gearbox Selection and Maintenance

## Gearbox Selection Procedure

Maximum existing motor acceleration torque  $T_{1B\text{Mot}}$  [Nm]



Calculate the maximum existing acceleration torque at the gearbox output

$$T_{2B\text{max exist.}} = T_{1B\text{Mot}} \times i \text{ [Nm]}$$



Compare the maximum existing acceleration torque at the gearbox output with the permissible acceleration torque at the gearbox output. If necessary, for high number of cycles, apply cycle factor from the chart below.

$$T_{2B\text{max exist.}} \leq T_{2B\text{perm.}} \times f_0$$



Existing average speed  $n_{1\text{ exist.}} \leq$  nominal speed  $n_{1N}$

Valid for an average torque of 30 % of the permissible output torque  $T_{2N}$



Compare the motor output dimensions such as shaft diameter, shaft length, bolt circle diameter, pilot diameter and holes with the gearbox input dimensions. Contact us for assistance.



Compare the radial and axial shaft load with the maximum permissible values

$$F_{2R\text{exist.}} \leq F_{2R\text{max}} \text{ [N]} \quad F_{2A\text{exist.}} \leq F_{2A\text{max}} \text{ [N]}$$

\*Above selection is based on S5 cyclical duty cycle [DC] of <60% and run time [RT] < 20 min. Contact us for sizing assistance for S1 continuous operation.

Cycle Factor [f0]	<1,000 cycles/hour	1,000-3,000 cycles/hour	3,000-5,000 cycles/hour	5,000-7,000 cycles/hour
<1 hours/day	1.00	0.85	0.75	0.75
<8 hours/day	0.75	0.65	0.65	0.55
<16 hours/day	0.70	0.60	0.55	0.40
<24 hours/day	0.65	0.55	0.40	0.35



## Gearbox Maintenance & Lubrication

Nidec Drive Technology Corporation hypoid gearboxes are maintenance-free and are supplied lubricated for life with a high-quality synthetic oil according to ISO VG-Class 150 (DIN 51 519). For continuous operation close to the thermal performance limit, we recommend performing regular leak inspection at the shaft seals. For these continuous duty cycles, we recommend changing the oil after approximately 15,000 operating hours. Please contact us for disassembly and lubrication instructions, lubricant options and quantities. Service kits with wear parts are available from our service department. Our products can also be sent back to the factory for inspection and lubrication.

Ratios higher than 15:1 utilize a planetary stage at the input or output section of the gearbox, resulting in separate lubrication chambers. The planetary chamber will utilize a high viscosity grease. This grease does not need to be changed. It is not advisable to disassemble the planetary section of the gearbox.

[www.nidec-dtc.com](http://www.nidec-dtc.com)

***Nidec***

---

**NIDEC DRIVE TECHNOLOGY CORPORATION**  
175 Wall Street, Glendale Heights, IL 60139 USA  
Phone: (800) 842-1479 • [info@nidec-dtc.com](mailto:info@nidec-dtc.com)