

NEV SERIES Right-angle Planetary

NEV D-Frame 2-Stage Specifications

Frame Size	D (115mm)					
Ratio	Units	Note	5	9	15	27
Nominal Output Torque	[Nm]	--	25	25	25	40
Maximum Acceleration Torque	[Nm]	--	55	75	75	80
Emergency Stop Torque	[Nm]	--	100	140	140	180
Nominal Input Speed	[rpm]	--	3000			
Maximum Input Speed	[rpm]	--	6000			
No Load Running Torque	[Nm]	--	0.45			
Permitted Radial Load	[N]	--	2200	2200	2600	2600
Permitted Axial Load	[N]	--	1100	1100	1300	1300
Moment of Inertia ($\leq \varnothing 14$)	[kgcm ²]	--	--	--	--	--
Moment of Inertia ($\leq \varnothing 19$)	[kgcm ²]	--	1.502	1.254	0.464	0.720
Efficiency	[%]	--	85			
Torsional Rigidity	[Nm/arcmin]	--	1.2	1.5	1.5	1.5
Maximum Torsional Backlash	[Arc-min]	--	≤ 30			
Noise Level	[dB]	--	≤ 73			
Protection Class	--	--	IP65			
Ambient Temperature	[°C]	--	0-40			
Permitted Housing Temperature	[°C]	--	90			
Weight (Solid Output Shaft)	[kg]	--	7.1			
Weight (Hollow Output Shaft)	[kg]	--	6.7			

NEV D-Frame (115mm) 2-Stage Dimensions – Ratios: 5:1, 9:1, 15:1, 27:1

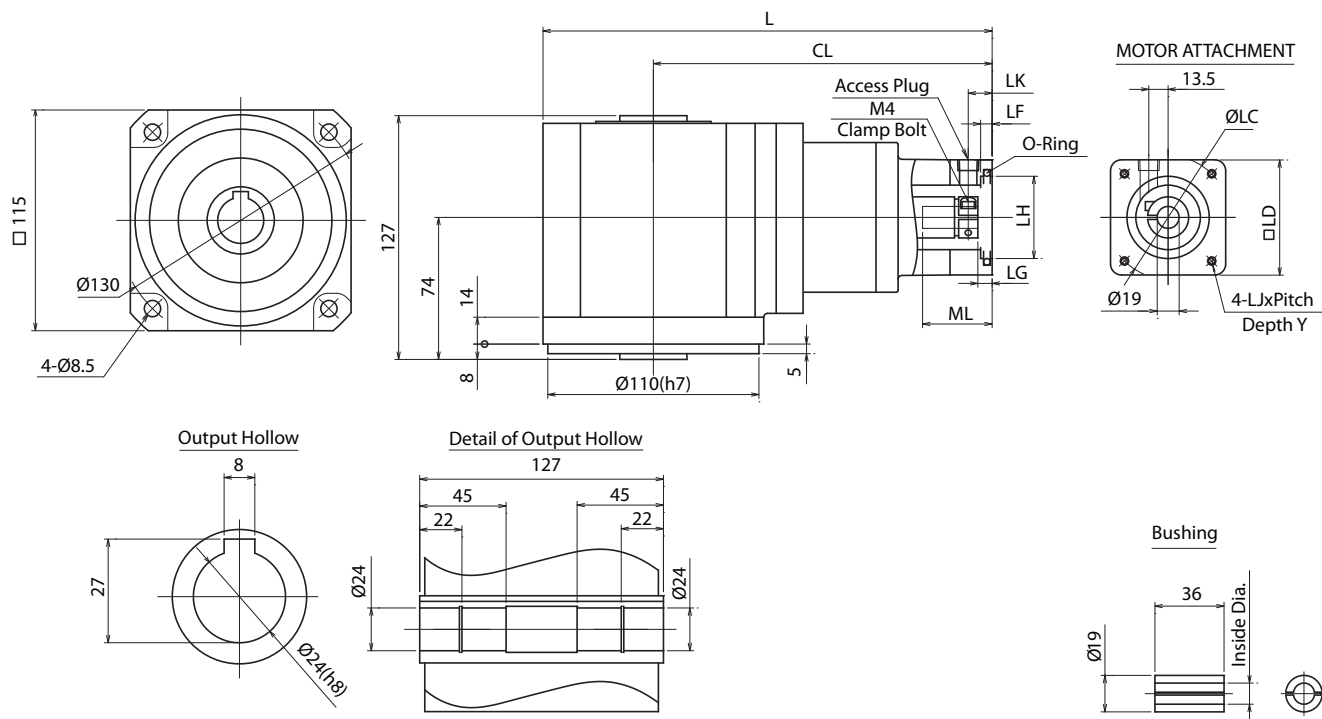
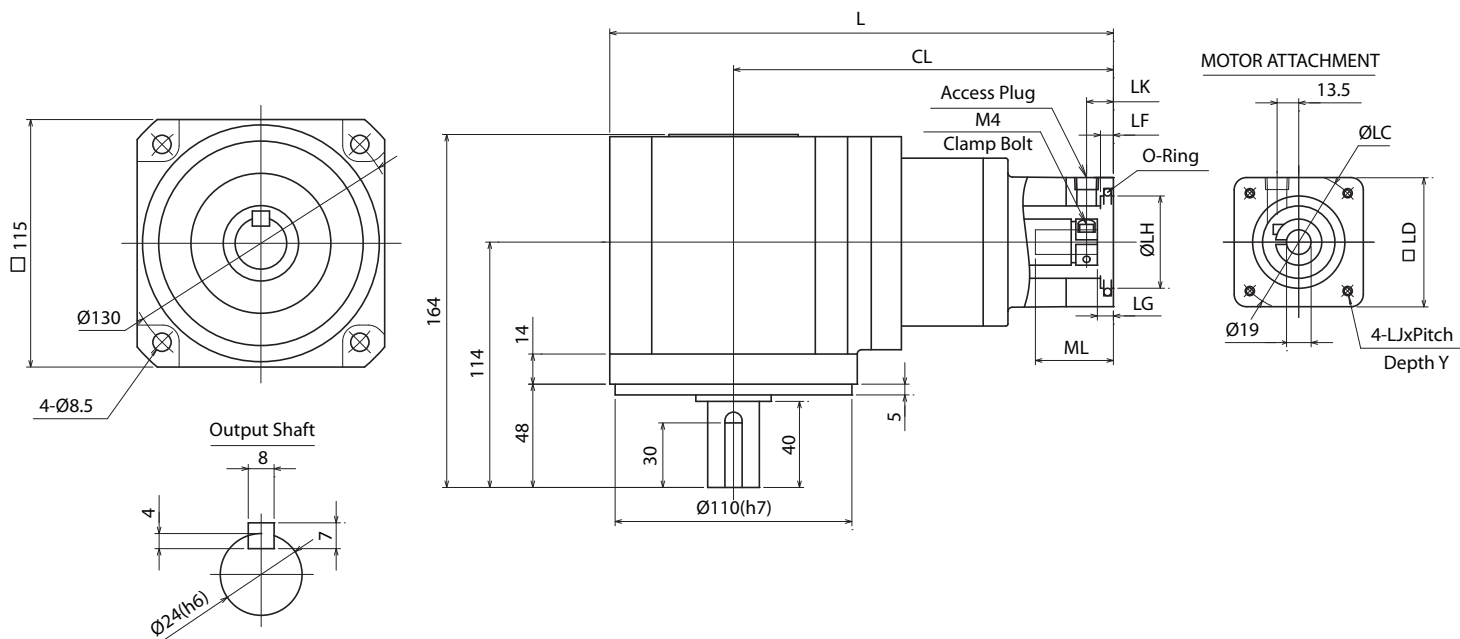

NEV SERIES Right-angle Planetary

NEV D-Frame 3-Stage Specifications

Frame Size	D (115mm)				
Ratio	Units	Note	45	75	105
Nominal Output Torque	[Nm]	--	45	50	50
Maximum Acceleration Torque	[Nm]	--	80	80	80
Emergency Stop Torque	[Nm]	--	180	180	180
Nominal Input Speed	[rpm]	--	3000		
Maximum Input Speed	[rpm]	--	6000		
No Load Running Torque	[Nm]	--	0.355		
Permitted Radial Load	[N]	--	2600	2600	2600
Permitted Axial Load	[N]	--	1300	1300	1300
Moment of Inertia ($\leq \varnothing 14$)	[kgcm ²]	--	0.806	0.694	0.648
Moment of Inertia ($\leq \varnothing 19$)	[kgcm ²]	--	--	--	--
Efficiency	[%]	--	80		
Torsional Rigidity	[Nm/arcmin]	--	1.5		
Maximum Torsional Backlash	[Arc-min]	--	≤ 30		
Noise Level	[dB]	--	≤ 67		
Protection Class	--	--	IP65		
Ambient Temperature	[°C]	--	0-40		
Permitted Housing Temperature	[°C]	--	90		
Weight (Solid Output Shaft)	[kg]	--	7.3		
Weight (Hollow Output Shaft)	[kg]	--	6.9		

NEV D-Frame (115mm) 3-Stage Dimensions – Ratios: 45:1, 75:1, 105:1

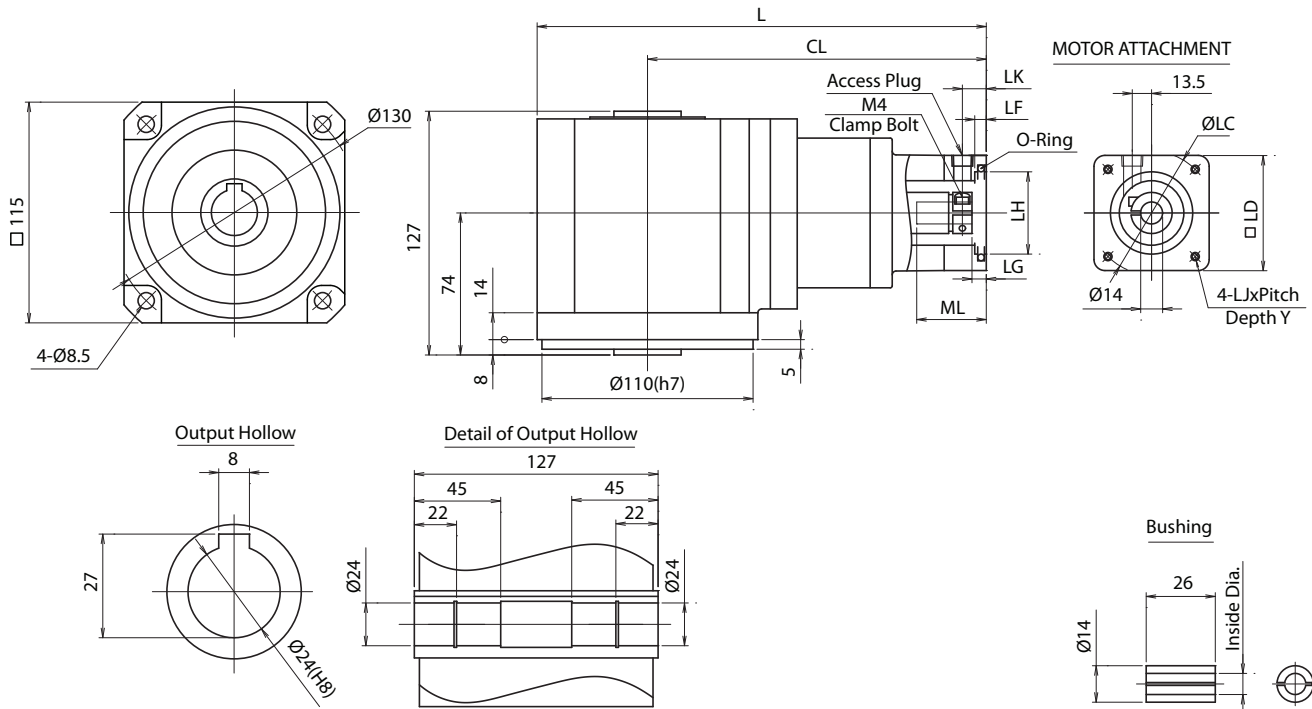
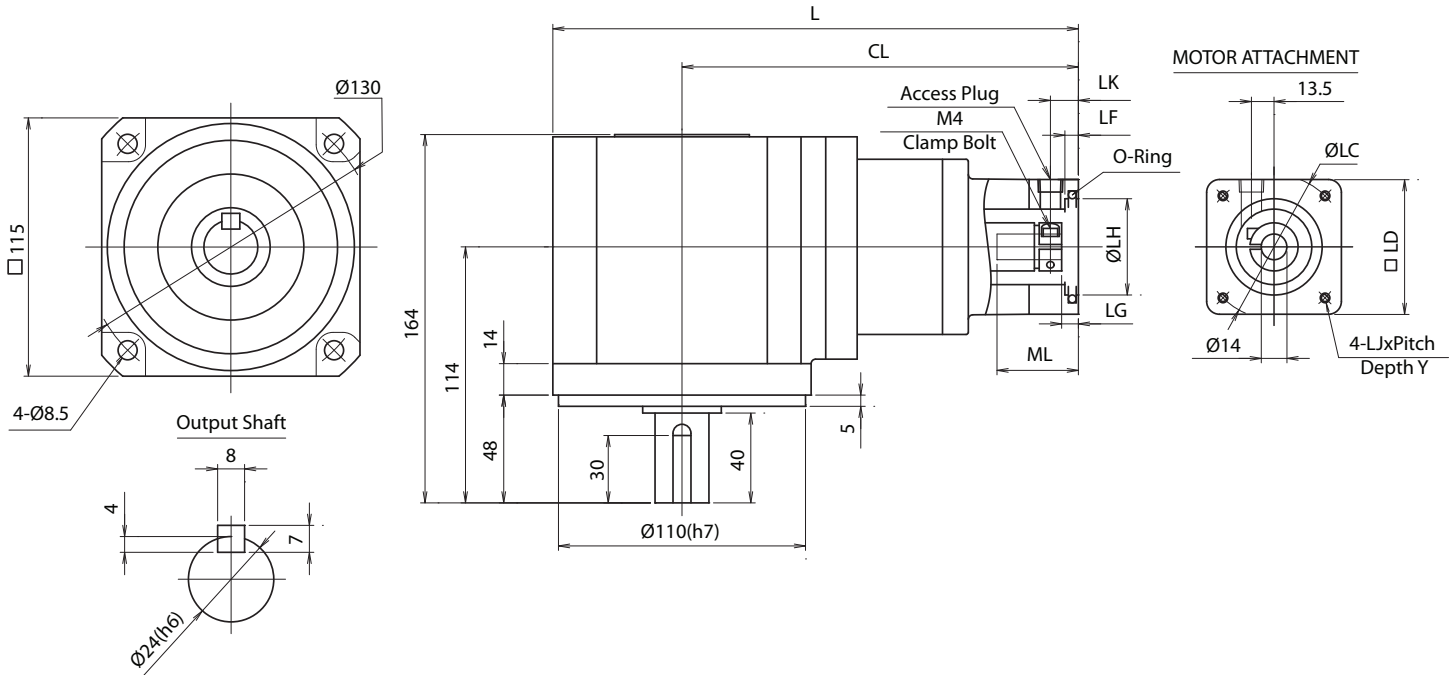

NEV