

EVS SERIES Right-angle Planetary

EVS 075 2-Stage Specifications

Frame Size	075									
Ratio	Unit	Note	3	4	5	6	7	8	9	10
Nominal Output Torque	[Nm]	*1	46	61	67	67	67	74	51	51
Maximum Acceleration Torque	[Nm]	*2	77	105	105	105	105	105	78	78
Maximum Torque	[Nm]	*3	90	121	121	119	119	117	93	93
Emergency Stop Torque	[Nm]	*4	130	170	220	220	220	220	170	170
Nominal Input Speed	[rpm]	*5	3000							
Maximum Input Speed	[rpm]	*6	6000							
No Load Running Torque	[Nm]	*7	1.13							
Maximum Radial Load	[N]	*8	4300							
Maximum Axial Load	[N]	*9	3900							
Moment of Inertia ($\leq \varnothing 8$)	[kgcm ²]	--	--	--	--	--	--	--	--	--
Moment of Inertia ($\leq \varnothing 14$)	[kgcm ²]	--	2.07	1.87	1.78	1.74	1.72	1.7	1.69	1.69
Moment of Inertia ($\leq \varnothing 19$)	[kgcm ²]	--	2.40	2.20	2.11	2.07	2.05	2.03	2.02	2.02
Moment of Inertia ($\leq \varnothing 28$)	[kgcm ²]	--	4.53	4.32	4.24	4.2	4.17	4.16	4.15	4.15
Efficiency	[%]	*10	93							
Torsional Rigidity	[Nm/arc-min]	*11	10							
Maximum Torsional Backlash	[arc-min]	--	≤ 4							
Noise Level	dB [A]	*12	≤ 80							
Protection Class	--	*13	IP54 (IP65)							
Ambient Temperature	[°C]	--	0-40							
Permitted Housing Temperature	[°C]	--	90							
Weight	[kg]	*14	4.8							

EVS 075 3-Stage Specifications

Frame Size	075									
Ratio	Unit	Note	15	16	20	25	28	30	35	40
Nominal Output Torque	[Nm]	*1	43	66	68	72	78	47	73	78
Maximum Acceleration Torque	[Nm]	*2	77	128	128	128	128	77	128	128
Maximum Torque	[Nm]	*3	77	128	128	128	128	77	128	128
Emergency Stop Torque	[Nm]	*4	170	220	220	220	220	170	220	220
Nominal Input Speed	[rpm]	*5	3300							
Maximum Input Speed	[rpm]	*6	6000							
No Load Running Torque	[Nm]	*7	0.55							
Maximum Radial Load	[N]	*8	4300							
Maximum Axial Load	[N]	*9	3900							
Moment of Inertia ($\leq \varnothing 8$)	[kgcm ²]	--	0.33	0.38	0.33	0.32	0.37	0.25	0.32	0.25
Moment of Inertia ($\leq \varnothing 14$)	[kgcm ²]	--	0.41	0.46	0.40	0.40	0.45	0.32	0.40	0.32
Moment of Inertia ($\leq \varnothing 19$)	[kgcm ²]	--	0.60	0.65	0.59	0.59	0.64	0.51	0.58	0.51
Moment of Inertia ($\leq \varnothing 28$)	[kgcm ²]	--	--	--	--	--	--	--	--	--
Efficiency	[%]	*10	88							
Torsional Rigidity	[Nm/arc-min]	*11	10							
Maximum Torsional Backlash	[arc-min]	--	≤ 7							
Noise Level	dB [A]	*12	≤ 80							
Protection Class	--	*13	IP54 (IP65)							
Ambient Temperature	[°C]	--	0-40							
Permitted Housing Temperature	[°C]	--	90							
Weight	[kg]	*14	4.1							

EVS 075 3-Stage Specifications

Frame Size	075										
Ratio	Unit	Note	45	50	60	70	80	90	100		
Nominal Output Torque	[Nm]	*1	47	73	73	73	78	52	52		
Maximum Acceleration Torque	[Nm]	*2	78	128	128	128	128	78	78		
Maximum Torque	[Nm]	*3	78	128	128	128	128	78	78		
Emergency Stop Torque	[Nm]	*4	170	220	220	220	220	170	170		
Nominal Input Speed	[rpm]	*5	3300								
Maximum Input Speed	[rpm]	*6	6000								
No Load Running Torque	[Nm]	*7	0.55								
Maximum Radial Load	[N]	*8	4300								
Maximum Axial Load	[N]	*9	3900								
Moment of Inertia ($\leq \varnothing 8$)	[kgcm ²]	--	0.32	0.25	0.25	0.25	0.25	0.25	0.25		
Moment of Inertia ($\leq \varnothing 14$)	[kgcm ²]	--	0.39	0.32	0.32	0.32	0.32	0.32	0.32		
Moment of Inertia ($\leq \varnothing 19$)	[kgcm ²]	--	0.58	0.51	0.51	0.51	0.51	0.51	0.51		
Moment of Inertia ($\leq \varnothing 28$)	[kgcm ²]	--	--	--	--	--	--	--	--		
Efficiency	[%]	*10	88								
Torsional Rigidity	[Nm/arc-min]	*11	10								
Maximum Torsional Backlash	[arc-min]	--	≤ 7								
Noise Level	dB [A]	*12	≤ 80								
Protection Class	--	*13	IP54 (IP65)								
Ambient Temperature	[°C]	--	0-40								
Permitted Housing Temperature	[°C]	--	90								
Weight	[kg]	*14	4.1								

*1) At nominal input speed, service life is 20,000 hours

*2) The maximum torque when starting or stopping operation. Apply Cycle Factor f_0 , found on page 468, for higher duty cycle applications

*3) Permitted 10,000 times during service life. Based on 10% of maximum radial load and smooth output shaft

*4) The maximum torque allowed under a stress situation. Permitted 1,000 times during service life

*5) The average input speed at nominal input torque. Maintain housing temperature below permitted value

*6) The maximum intermittent input speed

*7) Torque at no load applied to the input shaft at nominal input speed

*8) The maximum radial load that the gearbox can accept

*9) The maximum axial load that the gearbox can accept

*10) The efficiency at the nominal output torque rating

*11) This does not include lost motion

*12) Contact Nidec Drive Technology for the testing conditions and environment

*13) Various wash-down options are available. Contact Nidec Drive Technology for more details

*14) Weight may vary slightly between models

EVS SERIES Right-angle Planetary

EVS 075 2-Stage Dimensions

Input bore size $\leq \varnothing 14$ mm

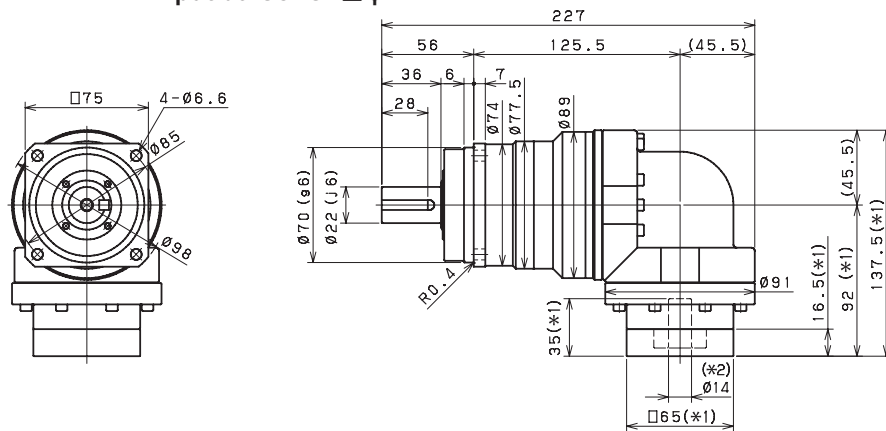

Input bore size $\leq \varnothing 19$ mm

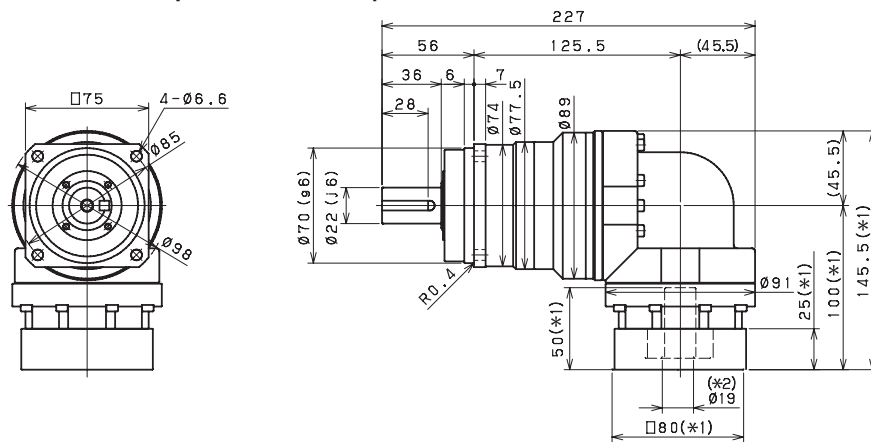

Input bore size $\leq \varnothing 28$ mm

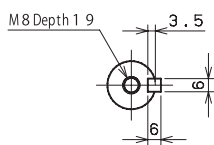
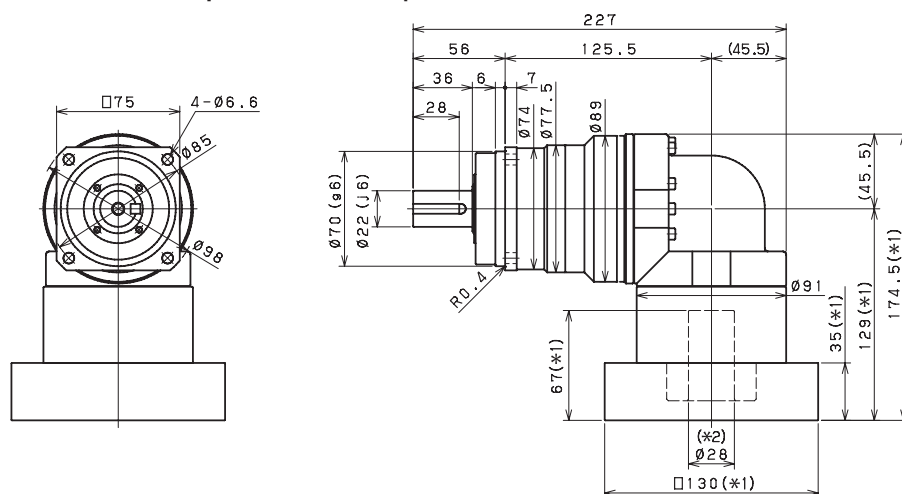

Keyed shaft

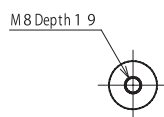

Smooth shaft

*1) Length will vary depending on motor

*2) Bushing will be inserted to adapt to motor shaft

EVS 075 3-Stage Dimensions

Input bore size $\leq \varnothing 8 \text{ mm}$

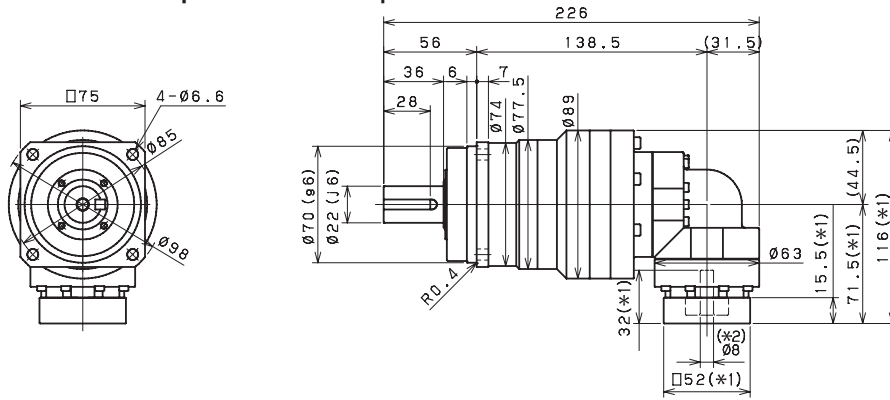

Input bore size $\leq \varnothing 14 \text{ mm}$

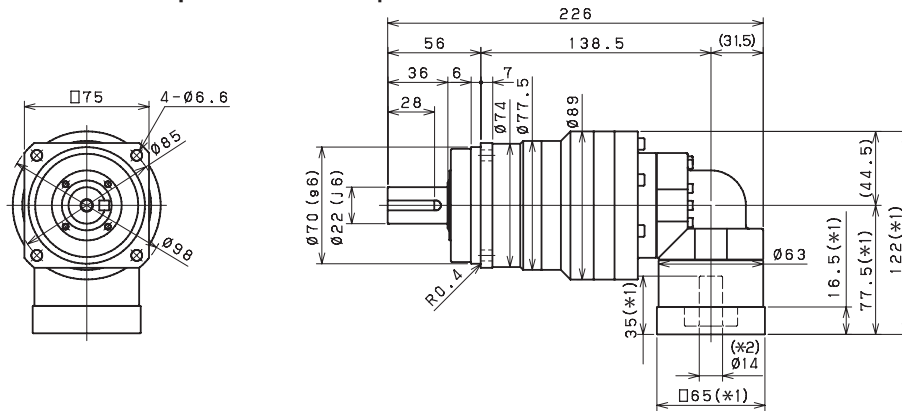

Input bore size $\leq \varnothing 19 \text{ mm}$

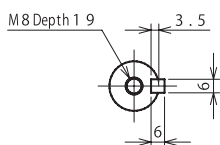
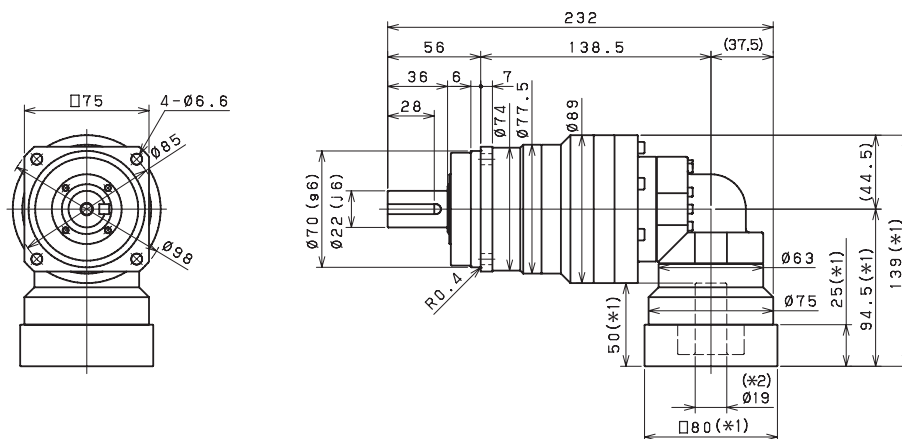

Keyed shaft

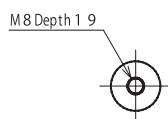

Smooth shaft

*1) Length will vary depending on motor

*2) Bushing will be inserted to adapt to motor shaft