

EVL SERIES Right-angle Planetary

EVL 235 2-Stage Specifications

Frame Size	235									
Ratio	Units	Note	3	4	5	6	7	8	9	10
Nominal Output Torque	[Nm]	*1	575	765	960	1208	1313	1313	1064	1064
Maximum Acceleration Torque	[Nm]	*2	1160	1555	1945	2112	2112	2063	1812	1529
Maximum Torque	[Nm]	*3	1336	1861	2328	2441	2441	2339	2032	1787
Emergency Stop Torque	[Nm]	*4	2500	3300	4000	4500	4500	4500	3600	3600
Nominal Input Speed	[rpm]	*5	1200							
Maximum Input Speed	[rpm]	*6	3000							
No Load Running Torque	[Nm]	*7	14.5							
Maximum Radial Load	[N]	*8	15000							
Maximum Axial Load	[N]	*9	14000							
Moment of Inertia ($\leq \varnothing 38$)	[kgcm ²]	--	--	--	--	--	--	--	--	--
Moment of Inertia ($\leq \varnothing 48$)	[kgcm ²]	--	148.0	122.9	113.3	108.1	104.7	102.7	101.6	101.0
Moment of Inertia ($\leq \varnothing 65$)	[kgcm ²]	--	223.2	198.1	188.6	183.3	180.0	178.0	176.8	176.2
Efficiency	[%]	*10	93							
Torsional Rigidity	[Nm/arcmin]	*11	400							
Maximum Torsional Backlash	[Arc-min]	--	≤ 8							
Noise Level	dB [A]	*12	≤ 85							
Protection Class	--	*13	IP54 (IP65)							
Ambient Temperature	[°C]	--	0-40							
Permitted Housing Temperature	[°C]	--	90							
Weight	[kg]	*14	68							

EVL 235 3-Stage Specifications

Frame Size	235									
Ratio	Units	Note	15	16	20	25	28	30	35	40
Nominal Output Torque	[Nm]	*1	858	1200	1200	1360	1440	948	1440	1440
Maximum Acceleration Torque	[Nm]	*2	1463	2112	2112	2112	2112	1463	2112	2112
Maximum Torque	[Nm]	*3	1463	2112	2112	2112	2112	1463	2112	2112
Emergency Stop Torque	[Nm]	*4	3600	4500	4500	4500	4500	3600	4500	4500
Nominal Input Speed	[rpm]	*5	1500							
Maximum Input Speed	[rpm]	*6	3000							
No Load Running Torque	[Nm]	*7	10.2							
Maximum Radial Load	[N]	*8	15000							
Maximum Axial Load	[N]	*9	14000							
Moment of Inertia ($\leq \varnothing 38$)	[kgcm ²]	--	36.32	37.24	35.75	35.47	36.39	34.39	35.21	34.25
Moment of Inertia ($\leq \varnothing 48$)	[kgcm ²]	--	66.14	67.06	65.57	65.28	66.21	64.21	65.03	64.07
Moment of Inertia ($\leq \varnothing 65$)	[kgcm ²]	--	--	--	--	--	--	--	--	--
Efficiency	[%]	*10	88							
Torsional Rigidity	[Nm/arcmin]	*11	400							
Maximum Torsional Backlash	[Arc-min]	--	≤ 11							
Noise Level	dB [A]	*12	≤ 85							
Protection Class	--	*13	IP54 (IP65)							
Ambient Temperature	[°C]	--	0-40							
Permitted Housing Temperature	[°C]	--	90							
Weight	[kg]	*14	70							

EVL 235 3-Stage Specifications

Frame Size	235										
Ratio	Units	Note	45	50	60	70	80	90	100		
Nominal Output Torque	[Nm]	*1	948	1440	1440	1440	1440	948	948		
Maximum Acceleration Torque	[Nm]	*2	1246	2112	2112	2112	1728	1246	1131		
Maximum Torque	[Nm]	*3	1246	2112	2112	2112	1728	1246	1131		
Emergency Stop Torque	[Nm]	*4	3600	4500	4500	4500	4500	3600	3600		
Nominal Input Speed	[rpm]	*5	1500								
Maximum Input Speed	[rpm]	*6	3000								
No Load Running Torque	[Nm]	*7	10.2								
Maximum Radial Load	[N]	*8	15000								
Maximum Axial Load	[N]	*9	14000								
Moment of Inertia ($\leq \varnothing 38$)	[kgcm ²]	--	35.10	34.18	34.14	34.11	34.10	34.09	34.08		
Moment of Inertia ($\leq \varnothing 48$)	[kgcm ²]	--	64.92	63.99	63.95	63.93	63.91	63.90	63.90		
Moment of Inertia ($\leq \varnothing 65$)	[kgcm ²]	--	--	--	--	--	--	--	--		
Efficiency	[%]	*10	88								
Torsional Rigidity	[Nm/arcmin]	*11	400								
Maximum Torsional Backlash	[Arc-min]	--	≤ 11								
Noise Level	dB [A]	*12	≤ 85								
Protection Class	--	*13	IP54 (IP65)								
Ambient Temperature	[°C]	--	0-40								
Permitted Housing Temperature	[°C]	--	90								
Weight	[kg]	*14	70								

- *1) At nominal input speed, service life is 20,000 hours
- *2) The maximum torque when starting or stopping operation. Apply Cycle Factor f_0 , found on page 468, for higher duty cycle applications
- *3) Permitted 10,000 times during service life. Based on 10% of maximum radial load and smooth output shaft
- *4) The maximum torque allowed under a stress situation. Permitted 1,000 times during service life
- *5) The average input speed at nominal input torque. Maintain housing temperature below permitted value
- *6) The maximum intermittent input speed
- *7) Torque at no load applied to the input shaft at nominal input speed
- *8) The maximum radial load that the gearbox can accept
- *9) The maximum axial load that the gearbox can accept
- *10) The efficiency at the nominal output torque rating
- *11) This does not include lost motion
- *12) Contact Nidec Drive Technology for the testing conditions and environment
- *13) Various wash-down options are available. Contact Nidec Drive Technology for more details
- *14) Weight may vary slightly between models

EVL SERIES Right-angle Planetary

EVL 235 2-Stage Dimensions

Input bore size $\leq \phi 48$ mm

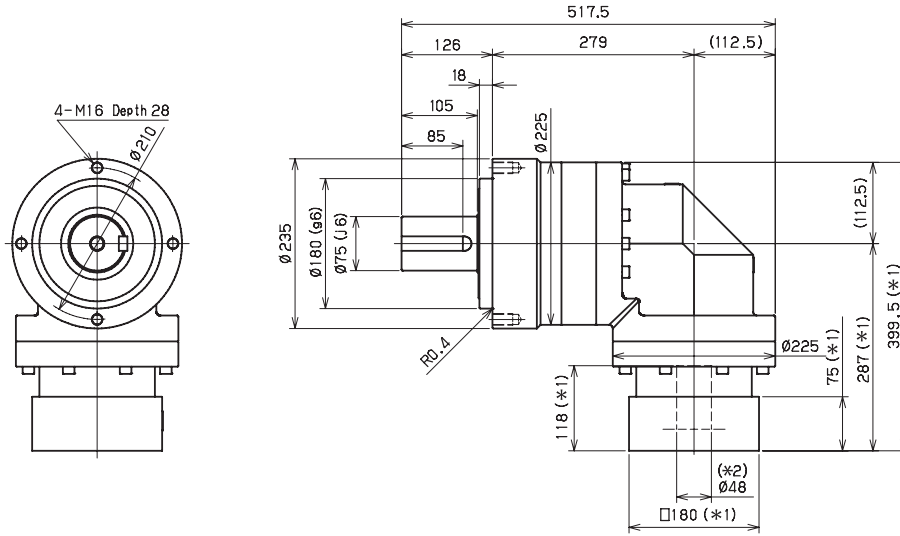

Input bore size $\leq \phi 65$ mm

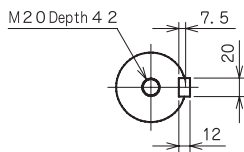
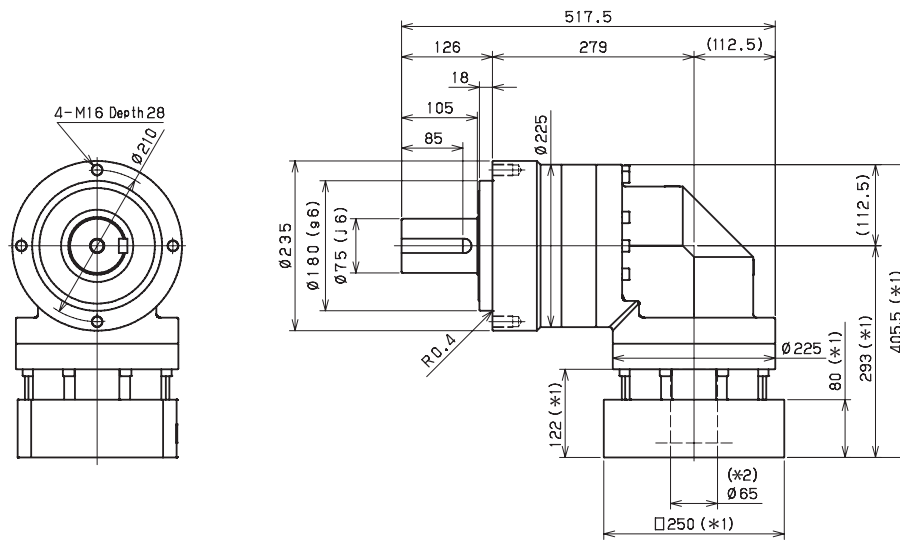

Keyed shaft

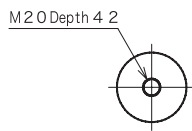

Smooth shaft

*1) Length will vary depending on motor.

*2) Bushing will be inserted to adapt to motor shaft

EVL 235 3-Stage Dimensions

Input bore size $\leq \varnothing 38$ mm

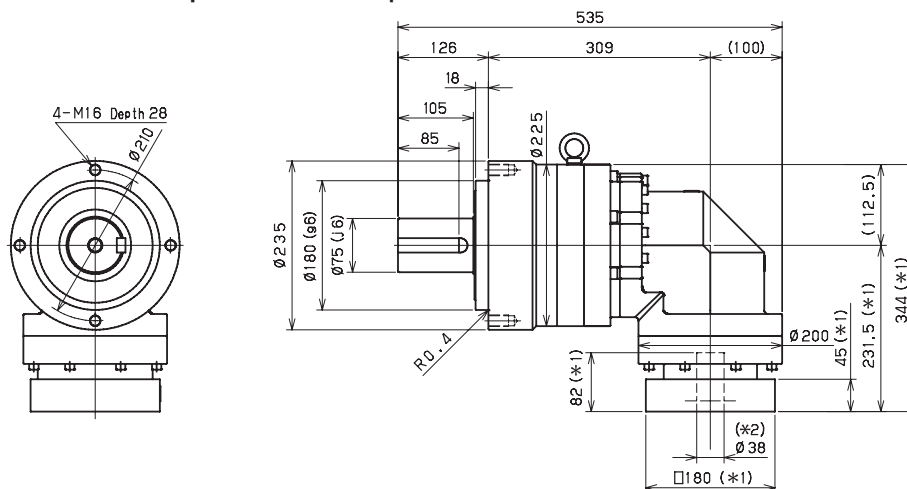

Input bore size $\leq \varnothing 48$ mm

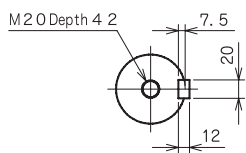
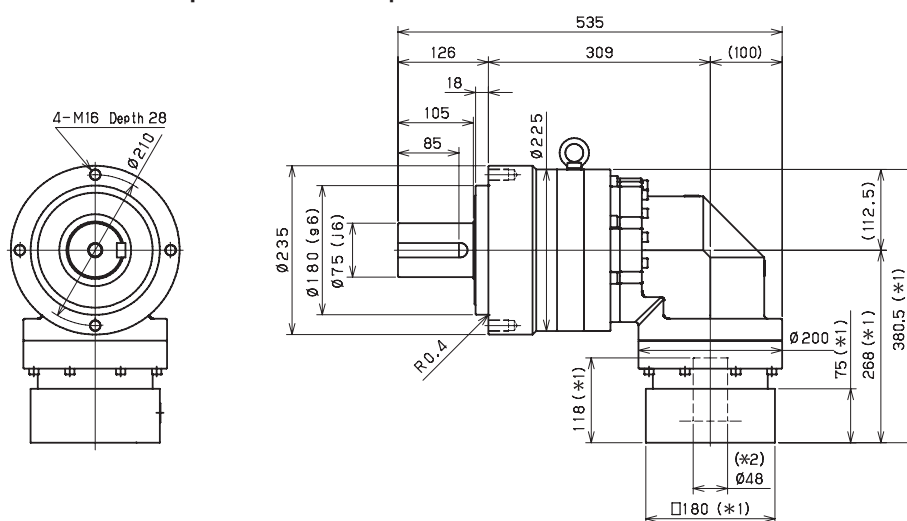

Keyed shaft

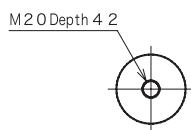

Smooth shaft

*1) Length will vary depending on motor.

*2) Bushing will be inserted to adapt to motor shaft