

EVL SERIES Right-angle Planetary

EVL 205 2-Stage Specifications

Frame Size	205									
Ratio	Units	Note	3	4	5	6	7	8	9	10
Nominal Output Torque	[Nm]	*1	421	604	646	646	646	646	478	478
Maximum Acceleration Torque	[Nm]	*2	679	904	1127	1315	1315	1315	931	931
Maximum Torque	[Nm]	*3	750	1064	1327	1498	1498	1498	1144	1144
Emergency Stop Torque	[Nm]	*4	1300	1700	2000	2500	2500	2500	2000	2000
Nominal Input Speed	[rpm]	*5	1500							
Maximum Input Speed	[rpm]	*6	4000							
No Load Running Torque	[Nm]	*7	10.8							
Maximum Radial Load	[N]	*8	15000							
Maximum Axial Load	[N]	*9	14000							
Moment of Inertia ($\leq \varnothing 28$)	[kgcm ²]	--	--	--	--	--	--	--	--	--
Moment of Inertia ($\leq \varnothing 38$)	[kgcm ²]	--	93.71	77.72	71.89	68.74	66.43	65.27	64.60	64.28
Moment of Inertia ($\leq \varnothing 48$)	[kgcm ²]	--	128.6	112.6	106.8	103.6	101.3	100.1	99.46	99.14
Moment of Inertia ($\leq \varnothing 65$)	[kgcm ²]	--	214.2	198.2	192.4	189.2	186.9	185.7	185.1	184.7
Efficiency	[%]	*10	93							
Torsional Rigidity	[Nm/arcmin]	*11	175							
Maximum Torsional Backlash	[Arc-min]	--	≤ 8							
Noise Level	dB [A]	*12	≤ 85							
Protection Class	--	*13	IP54 (IP65)							
Ambient Temperature	[°C]	--	0-40							
Permitted Housing Temperature	[°C]	--	90							
Weight	[kg]	*14	52							

EVL 205 3-Stage Specifications

Frame Size	205									
Ratio	Units	Note	15	16	20	25	28	30	35	40
Nominal Output Torque	[Nm]	*1	442	583	646	683	710	480	710	465
Maximum Acceleration Torque	[Nm]	*2	916	1315	1315	1315	1315	916	1315	1315
Maximum Torque	[Nm]	*3	916	1315	1315	1315	1315	916	1315	1315
Emergency Stop Torque	[Nm]	*4	2000	2500	2500	2500	2500	2000	2500	2500
Nominal Input Speed	[rpm]	*5	2100							
Maximum Input Speed	[rpm]	*6	4000							
No Load Running Torque	[Nm]	*7	4.7							
Maximum Radial Load	[N]	*8	15000							
Maximum Axial Load	[N]	*9	14000							
Moment of Inertia ($\leq \varnothing 28$)	[kgcm ²]	--	11.49	12.09	11.15	10.98	11.59	10.33	10.83	10.24
Moment of Inertia ($\leq \varnothing 38$)	[kgcm ²]	--	20.28	20.88	19.94	19.77	20.38	19.11	19.62	19.03
Moment of Inertia ($\leq \varnothing 48$)	[kgcm ²]	--	25.10	25.70	24.76	24.59	25.20	23.94	24.44	23.85
Moment of Inertia ($\leq \varnothing 65$)	[kgcm ²]	--	--	--	--	--	--	--	--	--
Efficiency	[%]	*10	88							
Torsional Rigidity	[Nm/arcmin]	*11	175							
Maximum Torsional Backlash	[Arc-min]	--	≤ 11							
Noise Level	dB [A]	*12	≤ 85							
Protection Class	--	*13	IP54 (IP65)							
Ambient Temperature	[°C]	--	0-40							
Permitted Housing Temperature	[°C]	--	90							
Weight	[kg]	*14	39							

EVL 205 3-Stage Specifications

Frame Size	205										
Ratio	Units	Note	45	50	60	70	80	90	100		
Nominal Output Torque	[Nm]	*1	480	710	710	710	710	480	480		
Maximum Acceleration Torque	[Nm]	*2	931	1315	1315	1315	1315	931	931		
Maximum Torque	[Nm]	*3	931	1315	1315	1315	1315	931	931		
Emergency Stop Torque	[Nm]	*4	2000	2500	2500	2500	2500	2000	2000		
Nominal Input Speed	[rpm]	*5	2100								
Maximum Input Speed	[rpm]	*6	4000								
No Load Running Torque	[Nm]	*7	4.7								
Maximum Radial Load	[N]	*8	15000								
Maximum Axial Load	[N]	*9	14000								
Moment of Inertia ($\leq \varnothing 28$)	[kgcm ²]	--	10.76	10.20	10.18	10.16	10.15	10.15	10.14		
Moment of Inertia ($\leq \varnothing 38$)	[kgcm ²]	--	19.55	18.99	18.96	18.95	18.94	18.93	18.93		
Moment of Inertia ($\leq \varnothing 48$)	[kgcm ²]	--	24.37	23.81	23.78	23.77	23.76	23.75	23.75		
Moment of Inertia ($\leq \varnothing 65$)	[kgcm ²]	--	--	--	--	--	--	--	--		
Efficiency	[%]	*10	88								
Torsional Rigidity	[Nm/arcmin]	*11	175								
Maximum Torsional Backlash	[Arc-min]	--	≤ 11								
Noise Level	dB [A]	*12	≤ 85								
Protection Class	--	*13	IP54 (IP65)								
Ambient Temperature	[°C]	--	0-40								
Permitted Housing Temperature	[°C]	--	90								
Weight	[kg]	*14	39								

*1) At nominal input speed, service life is 20,000 hours

*2) The maximum torque when starting or stopping operation. Apply Cycle Factor f_0 , found on page 468, for higher duty cycle applications

*3) Permitted 10,000 times during service life. Based on 10% of maximum radial load and smooth output shaft

*4) The maximum torque allowed under a stress situation. Permitted 1,000 times during service life

*5) The average input speed at nominal input torque. Maintain housing temperature below permitted value

*6) The maximum intermittent input speed

*7) Torque at no load applied to the input shaft at nominal input speed

*8) The maximum radial load that the gearbox can accept

*9) The maximum axial load that the gearbox can accept

*10) The efficiency at the nominal output torque rating

*11) This does not include lost motion

*12) Contact Nidec Drive Technology for the testing conditions and environment

*13) Various wash-down options are available. Contact Nidec Drive Technology for more details

*14) Weight may vary slightly between models

EVL SERIES Right-angle Planetary

EVL 205 2-Stage Dimensions

Input bore size $\leq \phi 38$ mm

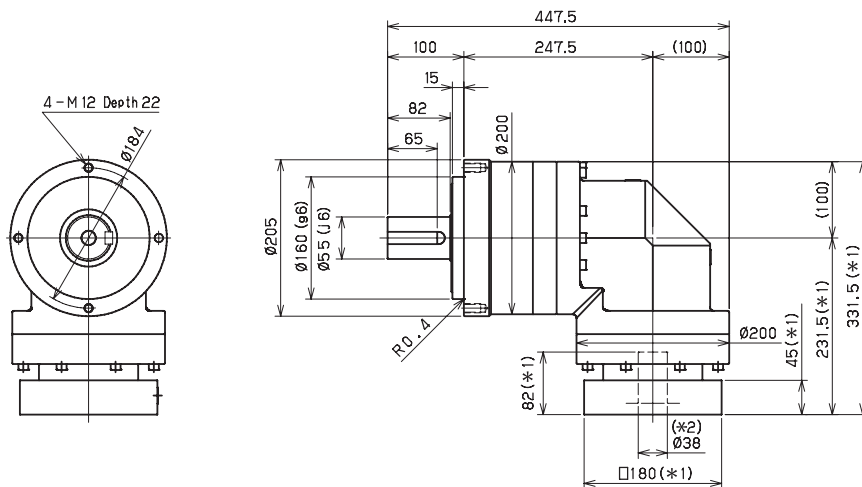

Input bore size $\leq \phi 48$ mm

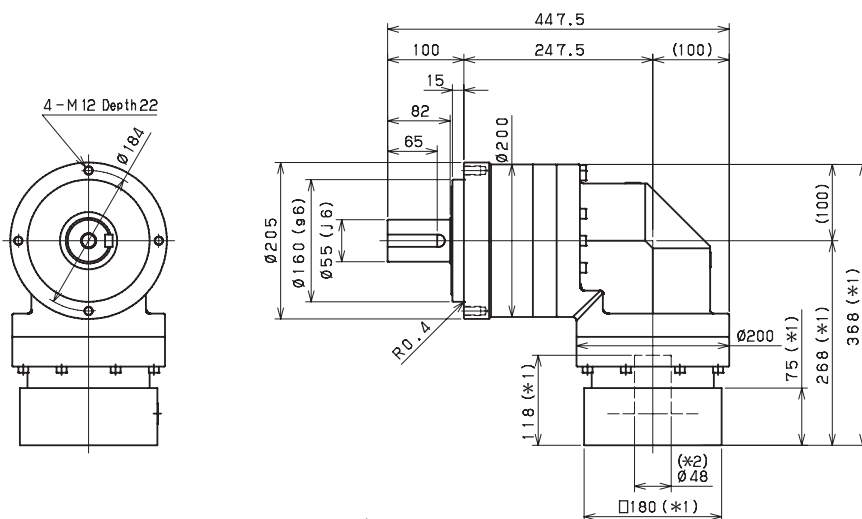

Input bore size $\leq \phi 65$ mm

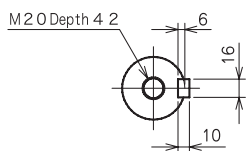
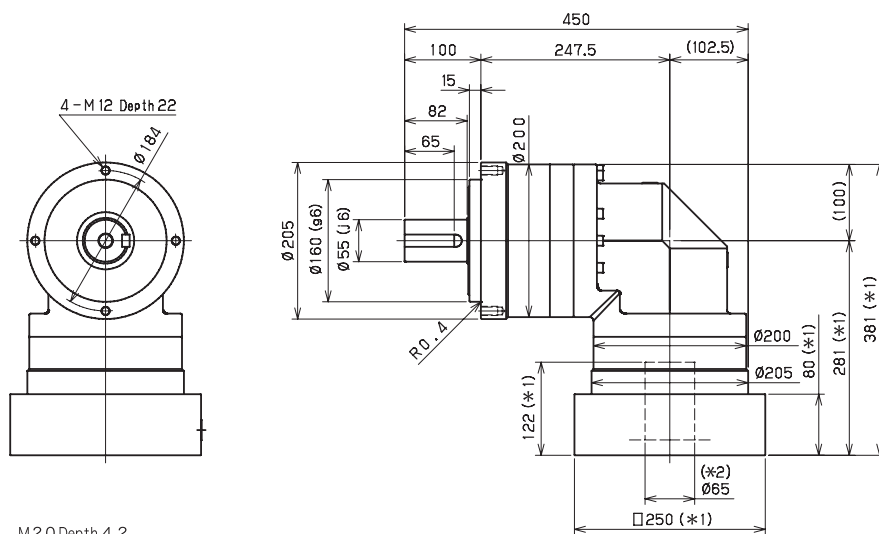

Keyed shaft

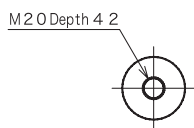

Smooth shaft

*1) Length will vary depending on motor.

*2) Bushing will be inserted to adapt to motor shaft

EVL 205 3-Stage Dimensions

Input bore size $\leq \varnothing 28$ mm

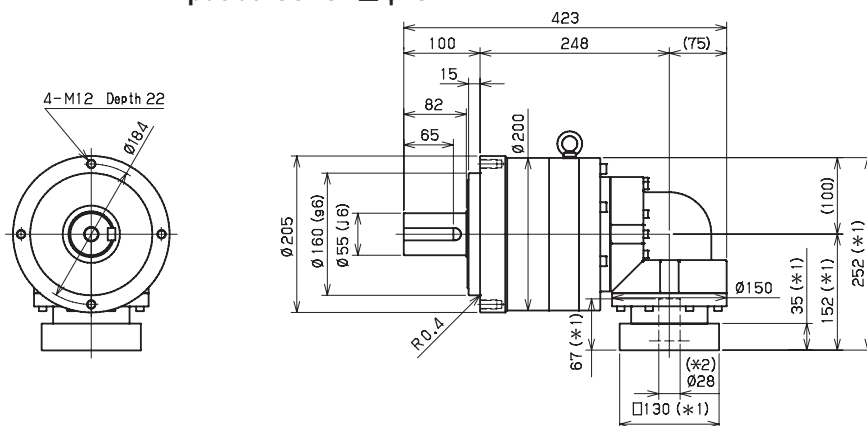

Input bore size $\leq \varnothing 38$ mm

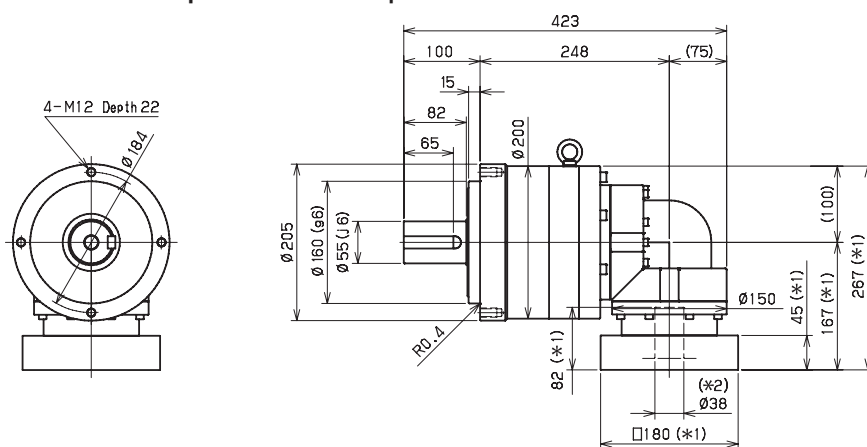

Input bore size $\leq \varnothing 48$ mm

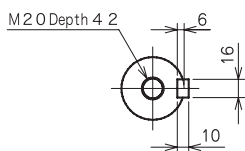
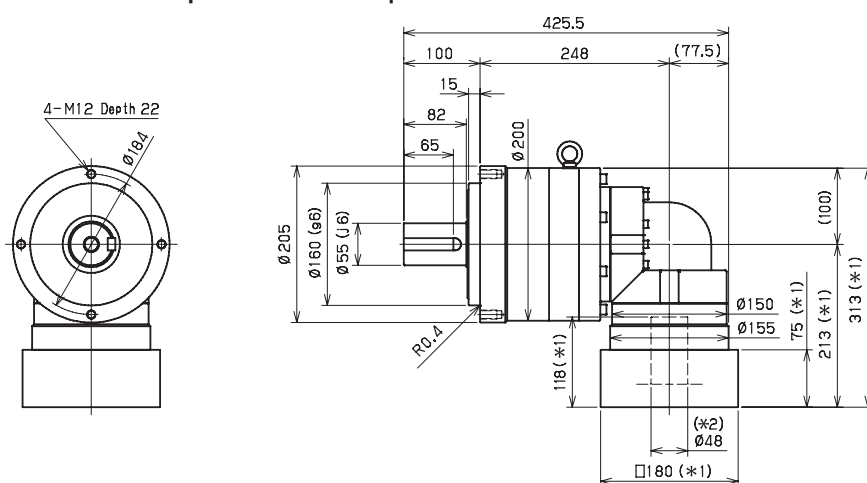

Keyed shaft

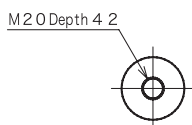

Smooth shaft

*1) Length will vary depending on motor.

*2) Bushing will be inserted to adapt to motor shaft