

EVL SERIES Right-angle Planetary

EVL 070 2-Stage Specifications

Frame Size	070									
Ratio	Unit	Note	3	4	5	6	7	8	9	10
Nominal Output Torque	[Nm]	*1	12	16	22	24	24	24	19	19
Maximum Acceleration Torque	[Nm]	*2	29	38	48	54	54	54	38	38
Maximum Torque	[Nm]	*3	33	45	56	63	63	61	45	45
Emergency Stop Torque	[Nm]	*4	50	65	80	90	90	90	65	65
Nominal Input Speed	[rpm]	*5	3300							
Maximum Input Speed	[rpm]	*6	6000							
No Load Running Torque	[Nm]	*7	0.33							
Maximum Radial Load	[N]	*8	1200							
Maximum Axial Load	[N]	*9	1100							
Moment of Inertia ($\leq \varnothing 8$)	[kgcm ²]	--	0.31	0.27	0.25	0.24	0.23	0.23	0.23	0.23
Moment of Inertia ($\leq \varnothing 14$)	[kgcm ²]	--	0.39	0.34	0.32	0.31	0.31	0.31	0.30	0.30
Moment of Inertia ($\leq \varnothing 19$)	[kgcm ²]	--	0.58	0.53	0.51	0.50	0.50	0.50	0.49	0.49
Efficiency	[%]	*10	93							
Torsional Rigidity	[Nm/arc-min]	*11	3							
Maximum Torsional Backlash	[arc-min]	--	≤ 6							
Noise Level	dB [A]	*12	≤ 80							
Protection Class	--	*13	IP54 (IP65)							
Ambient Temperature	[°C]	--	0-40							
Permitted Housing Temperature	[°C]	--	90							
Weight	[kg]	*14	1.9							

EVL 070 3-Stage Specifications

Frame Size	070									
Ratio	Unit	Note	15	16	20	25	28	30	35	40
Nominal Output Torque	[Nm]	*1	18	26	26	28	28	19	28	28
Maximum Acceleration Torque	[Nm]	*2	38	54	54	54	54	38	54	54
Maximum Torque	[Nm]	*3	38	54	54	54	54	38	54	54
Emergency Stop Torque	[Nm]	*4	65	90	90	90	90	65	90	90
Nominal Input Speed	[rpm]	*5	3800							
Maximum Input Speed	[rpm]	*6	6000							
No Load Running Torque	[Nm]	*7	0.20							
Maximum Radial Load	[N]	*8	1200							
Maximum Axial Load	[N]	*9	1100							
Moment of Inertia ($\leq \varnothing 8$)	[kgcm ²]	--	0.073	0.079	0.071	0.071	0.077	0.062	0.070	0.061
Moment of Inertia ($\leq \varnothing 14$)	[kgcm ²]	--	0.118	0.124	0.116	0.115	0.122	0.106	0.115	0.106
Moment of Inertia ($\leq \varnothing 19$)	[kgcm ²]	--	--	--	--	--	--	--	--	--
Efficiency	[%]	*10	88							
Torsional Rigidity	[Nm/arc-min]	*11	3							
Maximum Torsional Backlash	[arc-min]	--	≤ 9							
Noise Level	dB [A]	*12	≤ 80							
Protection Class	--	*13	IP65							
Ambient Temperature	[°C]	--	0-40							
Permitted Housing Temperature	[°C]	--	90							
Weight	[kg]	*14	1.7							

EVL 070 3-Stage Specifications

Frame Size	070										
Ratio	Unit	Note	45	50	60	70	80	90	100		
Nominal Output Torque	[Nm]	*1	19	28	28	28	28	19	19		
Maximum Acceleration Torque	[Nm]	*2	38	54	54	54	54	38	38		
Maximum Torque	[Nm]	*3	38	54	54	54	54	38	38		
Emergency Stop Torque	[Nm]	*4	65	90	90	90	90	65	65		
Nominal Input Speed	[rpm]	*5	3800								
Maximum Input Speed	[rpm]	*6	6000								
No Load Running Torque	[Nm]	*7	0.20								
Maximum Radial Load	[N]	*8	1200								
Maximum Axial Load	[N]	*9	1100								
Moment of Inertia ($\leq \varnothing 8$)	[kgcm ²]	--	0.070	0.061	0.061	0.061	0.061	0.061	0.061		
Moment of Inertia ($\leq \varnothing 14$)	[kgcm ²]	--	0.115	0.106	0.106	0.105	0.105	0.105	0.105		
Moment of Inertia ($\leq \varnothing 19$)	[kgcm ²]	--	--	--	--	--	--	--	--		
Efficiency	[%]	*10	88								
Torsional Rigidity	[Nm/arc-min]	*11	3								
Maximum Torsional Backlash	[arc-min]	--	≤ 9								
Noise Level	dB [A]	*12	≤ 80								
Protection Class	--	*13	IP54 (IP65)								
Ambient Temperature	[°C]	--	0-40								
Permitted Housing Temperature	[°C]	--	90								
Weight	[kg]	*14	1.7								

*1) At nominal input speed, service life is 20,000 hours

*2) The maximum torque when starting or stopping operation. Apply Cycle Factor f_0 , found on page 468, for higher duty cycle applications

*3) Permitted 10,000 times during service life. Based on 10% of maximum radial load and smooth output shaft

*4) The maximum torque allowed under a stress situation. Permitted 1,000 times during service life

*5) The average input speed at nominal input torque. Maintain housing temperature below permitted value

*6) The maximum intermittent input speed

*7) Torque at no load applied to the input shaft at nominal input speed

*8) The maximum radial load that the gearbox can accept

*9) The maximum axial load that the gearbox can accept

*10) The efficiency at the nominal output torque rating

*11) This does not include lost motion

*12) Contact Nidec Drive Technology for the testing conditions and environment

*13) Various wash-down options are available. Contact Nidec Drive Technology for more details

*14) Weight may vary slightly between models

EVL SERIES Right-angle Planetary

EVL 070 2-Stage Dimensions

Input bore size $\leq \varnothing 8$ mm

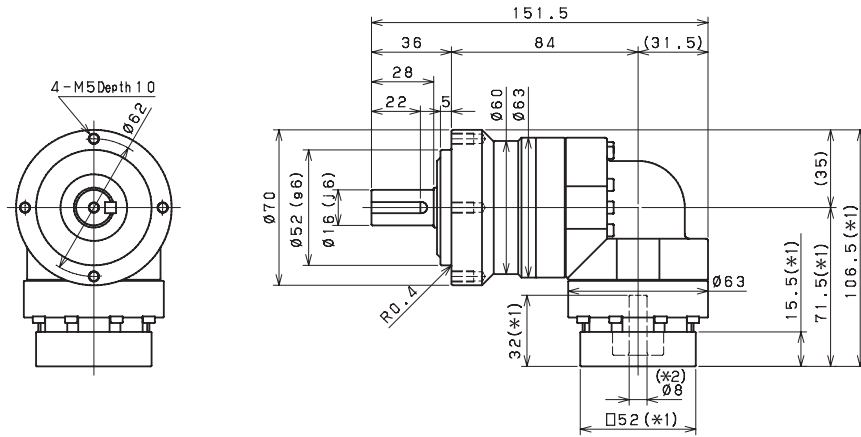

Input bore size $\leq \varnothing 14$ mm

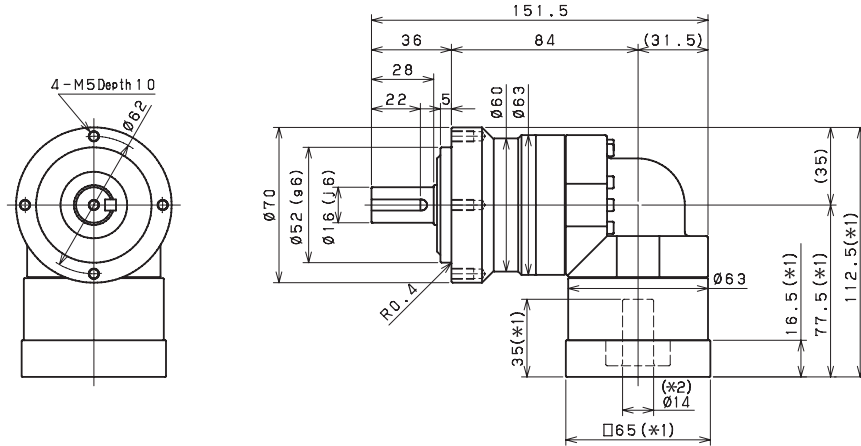

Input bore size $\leq \varnothing 19$ mm

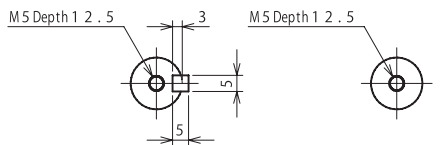
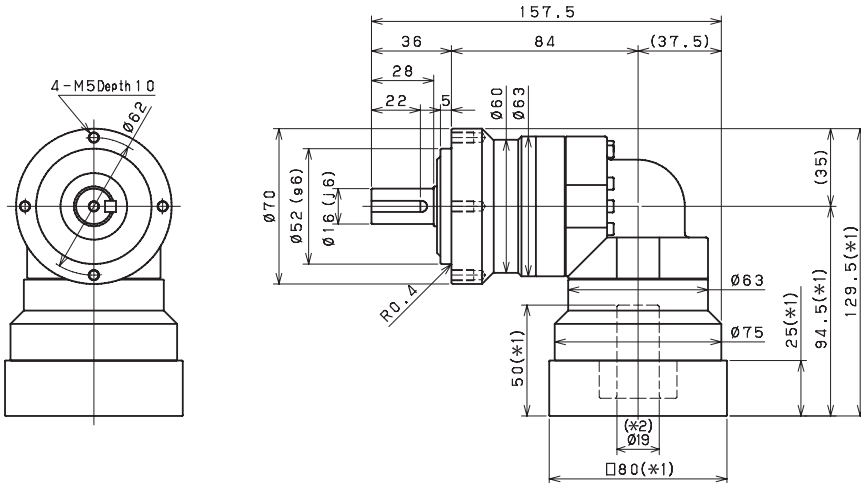

Keyed shaft

Smooth shaft

*1) Length will vary depending on motor

*2) Bushing will be inserted to adapt to motor shaft

EVL 070 3-Stage Dimensions

Input bore size $\leq \phi 8 \text{ mm}$

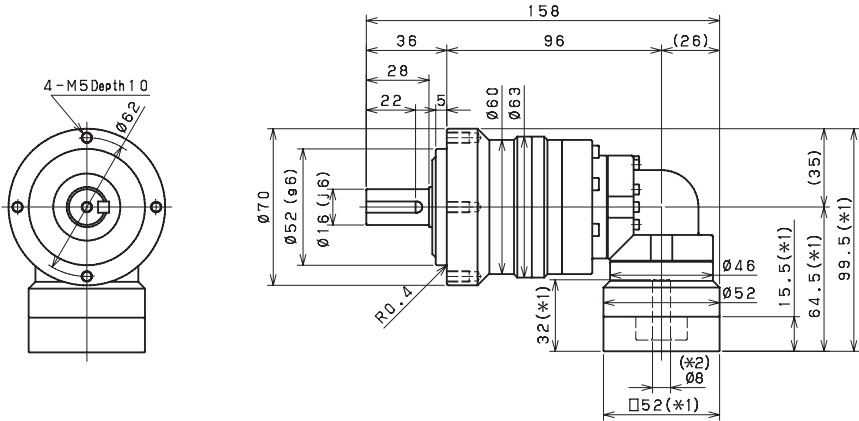

Input bore size $\leq \phi 14 \text{ mm}$

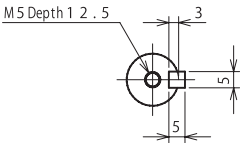
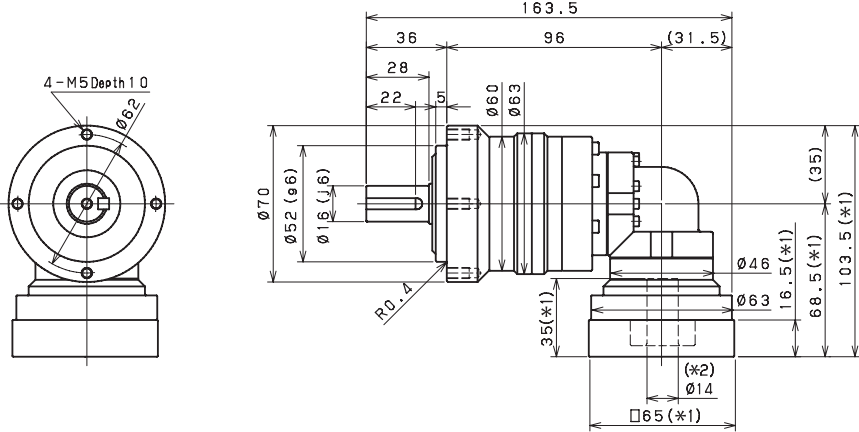

Keyed shaft

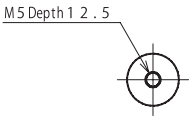

Smooth shaft

- *1) Length will vary depending on motor
- *2) Bushing will be inserted to adapt to motor shaft