

# EVB SERIES Right-angle Planetary

## EVB 140 2-Stage Specifications

Frame Size	140									
Ratio	Unit	Note	3	4	5	6	7	8	9	10
Nominal Output Torque	[Nm]	*1	132	181	205	266	307	307	233	233
Maximum Acceleration Torque	[Nm]	*2	296	389	458	595	687	687	480	480
Maximum Torque	[Nm]	*3	329	452	531	664	766	766	559	559
Emergency Stop Torque	[Nm]	*4	700	950	1100	1100	1100	1100	750	750
Nominal Input Speed	[rpm]	*5	2000							
Maximum Input Speed	[rpm]	*6	4000							
No Load Running Torque	[Nm]	*7	3.26							
Maximum Radial Load	[N]	*8	9100							
Maximum Axial Load	[N]	*9	8200							
Moment of Inertia ( $\leq \varnothing 19$ )	[kgcm <sup>2</sup> ]	--	--	--	--	--	--	--	--	--
Moment of Inertia ( $\leq \varnothing 28$ )	[kgcm <sup>2</sup> ]	--	23.13	18.57	16.91	16.01	15.58	15.23	14.77	14.66
Moment of Inertia ( $\leq \varnothing 38$ )	[kgcm <sup>2</sup> ]	--	27.50	22.94	21.28	20.38	19.95	19.61	19.41	19.03
Moment of Inertia ( $\leq \varnothing 48$ )	[kgcm <sup>2</sup> ]	--	40.73	36.17	34.51	33.61	33.18	32.84	32.37	32.26
Efficiency	[%]	*10	93							
Torsional Rigidity	[Nm/arc-min]	*11	60							
Maximum Torsional Backlash	[arc-min]	--	$\leq 4$							
Noise Level	dB [A]	*12	$\leq 85$							
Protection Class	--	*13	IP54 (IP65)							
Ambient Temperature	[°C]	--	0-40							
Permitted Housing Temperature	[°C]	--	90							
Weight	[kg]	*14	19.1							

## EVB 140 3-Stage Specifications

Frame Size	140									
Ratio	Unit	Note	15	16	20	25	28	30	35	40
Nominal Output Torque	[Nm]	*1	230	307	316	352	352	240	352	337
Maximum Acceleration Torque	[Nm]	*2	456	687	687	687	687	456	687	687
Maximum Torque	[Nm]	*3	456	687	687	687	687	456	687	687
Emergency Stop Torque	[Nm]	*4	750	1100	1100	1100	1100	750	1100	1100
Nominal Input Speed	[rpm]	*5	2300							
Maximum Input Speed	[rpm]	*6	4000							
No Load Running Torque	[Nm]	*7	2.56							
Maximum Radial Load	[N]	*8	9100							
Maximum Axial Load	[N]	*9	8200							
Moment of Inertia ( $\leq \varnothing 19$ )	[kgcm <sup>2</sup> ]	--	6.40	7.29	6.22	6.15	7.09	4.99	6.09	4.95
Moment of Inertia ( $\leq \varnothing 28$ )	[kgcm <sup>2</sup> ]	--	8	8.88	7.81	7.75	8.68	6.58	7.69	6.54
Moment of Inertia ( $\leq \varnothing 38$ )	[kgcm <sup>2</sup> ]	--	15.07	15.96	14.89	14.82	15.76	13.66	14.76	13.61
Moment of Inertia ( $\leq \varnothing 48$ )	[kgcm <sup>2</sup> ]	--	--	--	--	--	--	--	--	--
Efficiency	[%]	*10	88							
Torsional Rigidity	[Nm/arc-min]	*11	60							
Maximum Torsional Backlash	[arc-min]	--	$\leq 7$							
Noise Level	dB [A]	*12	$\leq 85$							
Protection Class	--	*13	IP54 (IP65)							
Ambient Temperature	[°C]	--	0-40							
Permitted Housing Temperature	[°C]	--	90							
Weight	[kg]	*14	19.6							

## EVB 140 3-Stage Specifications

Frame Size	140										
Ratio	Unit	Note	45	50	60	70	80	90	100		
Nominal Output Torque	[Nm]	*1	240	352	352	352	352	240	240		
Maximum Acceleration Torque	[Nm]	*2	480	687	687	687	687	480	480		
Maximum Torque	[Nm]	*3	480	687	687	687	687	480	480		
Emergency Stop Torque	[Nm]	*4	750	1100	1100	1100	1100	750	750		
Nominal Input Speed	[rpm]	*5	2300								
Maximum Input Speed	[rpm]	*6	4000								
No Load Running Torque	[Nm]	*7	2.56								
Maximum Radial Load	[N]	*8	9100								
Maximum Axial Load	[N]	*9	8200								
Moment of Inertia ( $\leq \varnothing 19$ )	[kgcm <sup>2</sup> ]	--	6.07	4.93	4.92	4.91	4.91	4.91	4.91		
Moment of Inertia ( $\leq \varnothing 28$ )	[kgcm <sup>2</sup> ]	--	7.66	6.52	6.51	6.51	6.50	6.50	6.50		
Moment of Inertia ( $\leq \varnothing 38$ )	[kgcm <sup>2</sup> ]	--	14.74	13.59	13.59	13.58	13.58	13.57	13.57		
Moment of Inertia ( $\leq \varnothing 48$ )	[kgcm <sup>2</sup> ]	--	--	--	--	--	--	--	--		
Efficiency	[%]	*10	88								
Torsional Rigidity	[Nm/arc-min]	*11	60								
Maximum Torsional Backlash	[arc-min]	--	$\leq 7$								
Noise Level	dB [A]	*12	$\leq 85$								
Protection Class	--	*13	IP54 (IP65)								
Ambient Temperature	[°C]	--	0-40								
Permitted Housing Temperature	[°C]	--	90								
Weight	[kg]	*14	19.6								

\*1) At nominal input speed, service life is 20,000 hours

\*2) The maximum torque when starting or stopping operation. Apply Cycle Factor  $f_0$ , found on page 468, for higher duty cycle applications

\*3) Permitted 10,000 times during service life. Based on 10% of maximum radial load and smooth output shaft

\*4) The maximum torque allowed under a stress situation. Permitted 1,000 times during service life

\*5) The average input speed at nominal input torque. Maintain housing temperature below permitted value

\*6) The maximum intermittent input speed

\*7) Torque at no load applied to the input shaft at nominal input speed

\*8) The maximum radial load that the gearbox can accept

\*9) The maximum axial load that the gearbox can accept

\*10) The efficiency at the nominal output torque rating

\*11) This does not include lost motion

\*12) Contact Nidec Drive Technology for the testing conditions and environment

\*13) Various wash-down options are available. Contact Nidec Drive Technology for more details

\*14) Weight may vary slightly between models

# EVB SERIES Right-angle Planetary

## EVB 140 2-Stage Dimensions

Input bore size  $\leq \varnothing 28$  mm

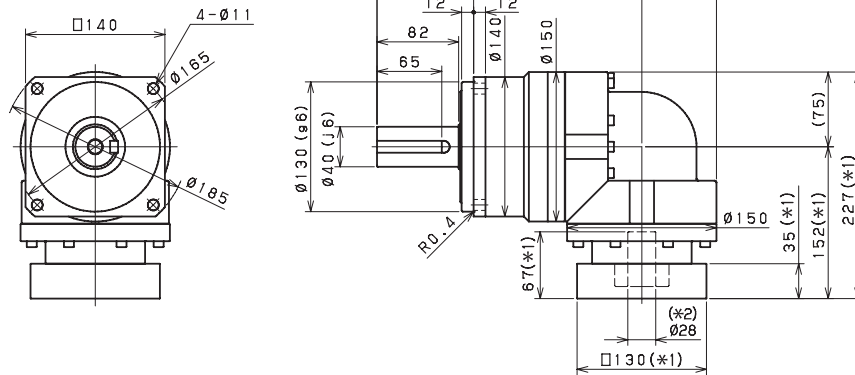

Input bore size  $\leq \varnothing 38$  mm

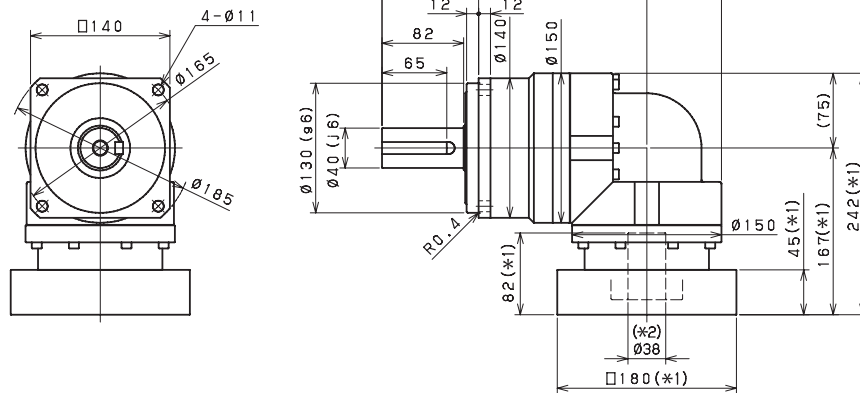

Input bore size  $\leq \varnothing 48$  mm

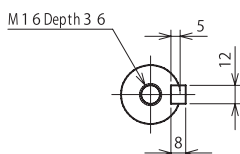
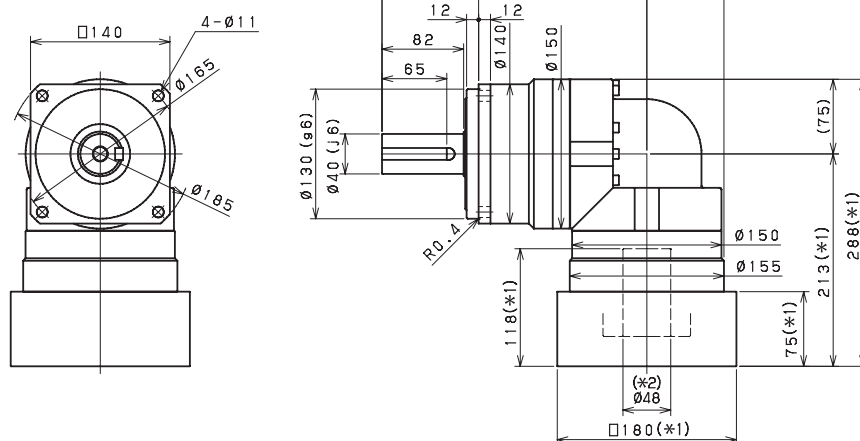

Keyed shaft

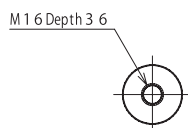

Smooth shaft

\*1) Length will vary depending on motor

\*2) Bushing will be inserted to adapt to motor shaft

## EVB 140 3-Stage Dimensions

Input bore size  $\leq \phi 19$  mm

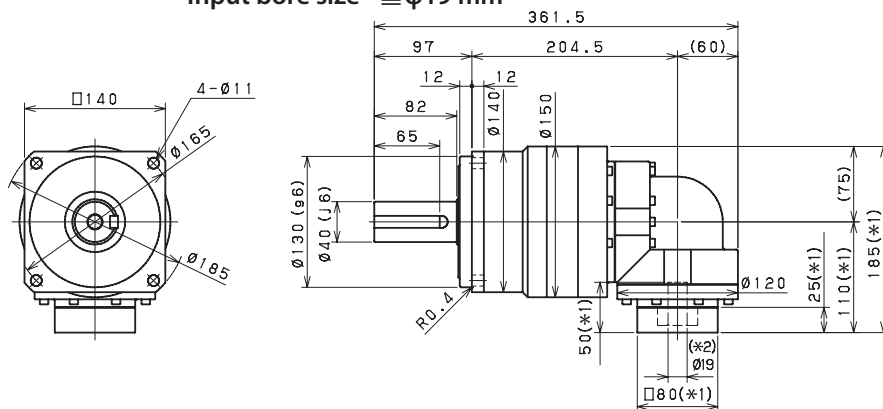

Input bore size  $\leq \phi 28$  mm

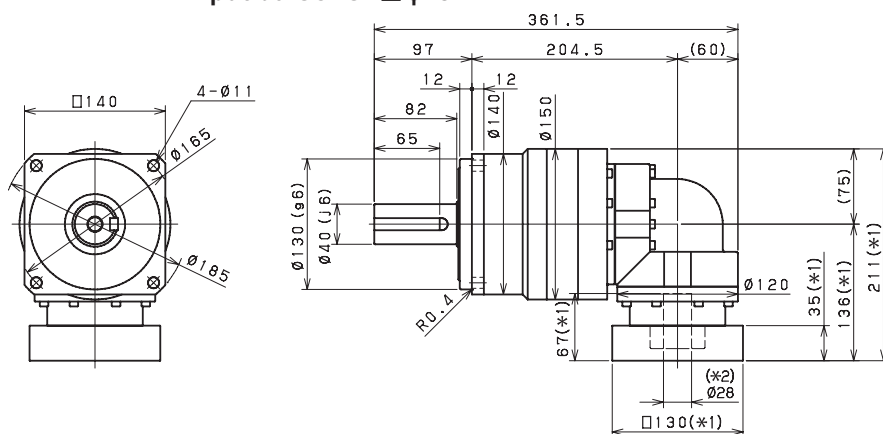

Input bore size  $\leq \phi 38$  mm

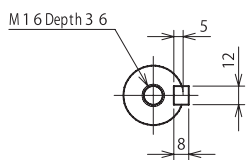
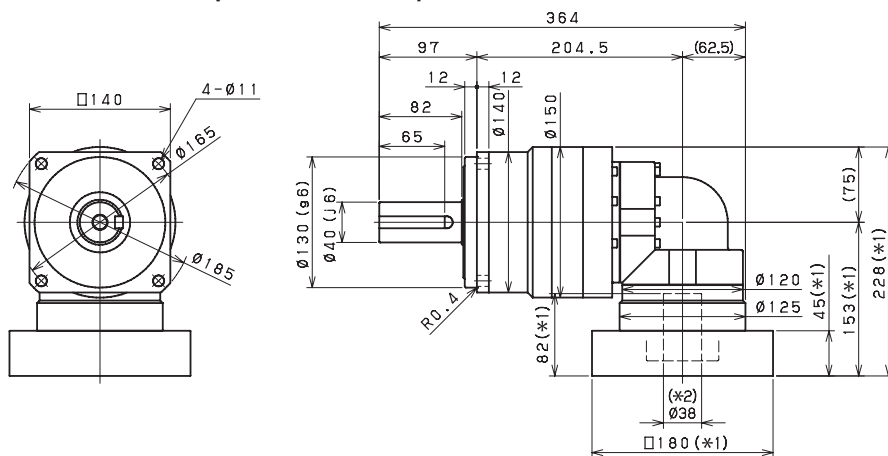

Keyed shaft

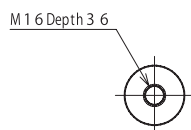

Smooth shaft

\*1) Length will vary depending on motor

\*2) Bushing will be inserted to adapt to motor shaft