

EJS 076 1-Stage Specifications

Frame Size	076					
Ratio	--	5	7.5	10	15	20
Nominal Output Torque	[Nm]	237	300	345	385	381
Maximum Acceleration Torque	[Nm]	330	420	476	517	502
Emergency Stop Torque	[Nm]	474	600	690	770	762
No Load Running Torque *1	[Nm]	1.24				
Nominal Input Speed	[rpm]	2,000				
Maximum Continuous Input Speed	[rpm]	3,000				
Maximum Cyclic Input Speed	[rpm]	3,000				
Maximum Radial Load *2	[N]	10,235				
Maximum Axial Load *3	[N]	10,235				
Moment of Inertia ($\leq \varnothing 19$)	[kgcm ²]	13.98	10.74	9.6	8.79	8.51
Efficiency *4	[%]	92	91	90	88	85
Torsional Rigidity	[Nm/arcmin]	41.6				
Maximum Torsional Backlash (Standard)	[Arc-min]	≤ 10				
Maximum Torsional Backlash (Low)	[Arc-min]	≤ 4				
Noise Level *5	dB [A]	≤ 83				
Weight *6	[kg]	41				
Ambient Temperature	[°C]	-23 ~ 93				
Permitted Housing Temperature	[°C]	100				
Service Life	[Hours]	20,000				
Protection Class	--	IP 69K				
Lubrication	--	Synthetic Food Grade Oil				
Mounting Position	--	Any				

*1) Torque at no load applied to the input shaft at 2,000 rpm

*2) The maximum radial load the gearbox can accept

*3) The maximum axial load the gearbox can accept

*4) The efficiency at the nominal output torque rating

*5) Measured with no load applied to the input shaft at 2,000 rpm

*6) Weight may vary slightly between models

EJS 076 1-Stage Specifications

Frame Size	076					
Ratio	--	25	30	40	50	60
Nominal Output Torque	[Nm]	396	393	375	361	347
Maximum Acceleration Torque	[Nm]	519	535	511	493	473
Emergency Stop Torque	[Nm]	792	786	750	722	694
No Load Running Torque *1	[Nm]	1.24				
Nominal Input Speed	[rpm]	2,000				
Maximum Continuous Input Speed	[rpm]	3,000				
Maximum Cyclic Input Speed	[rpm]	3,000				
Maximum Radial Load *2	[N]	10,235				
Maximum Axial Load *3	[N]	10,235				
Moment of Inertia ($\leq \varnothing 19$)	[kgcm ²]	8.38	8.31	8.23	8.20	8.18
Efficiency *4	[%]	84	80	76	73	70
Torsional Rigidity	[Nm/arcmin]	41.6				
Maximum Torsional Backlash (Standard)	[Arc-min]	≤ 10				
Maximum Torsional Backlash (Low)	[Arc-min]	≤ 4				
Noise Level *5	dB [A]	≤ 83				
Weight *6	[kg]	41				
Ambient Temperature	[°C]	-23 ~ 93				
Permitted Housting Temperature	[°C]	100				
Service Life	[Hours]	20,000				
Protection Class	--	IP 69K				
Lubrication	--	Synthetic Food Grade Oil				
Mounting Position	--	Any				

*1) Torque at no load applied to the input shaft at 2,000 rpm

*2) The maximum radial load the gearbox can accept

*3) The maximum axial load the gearbox can accept

*4) The efficiency at the nominal output torque rating

*5) Measured with no load applied to the input shaft at 2,000 rpm

*6) Weight may vary slightly between models

EJS SERIES Right-angle Worm

EJS Dimensions – Hollow Output Shaft

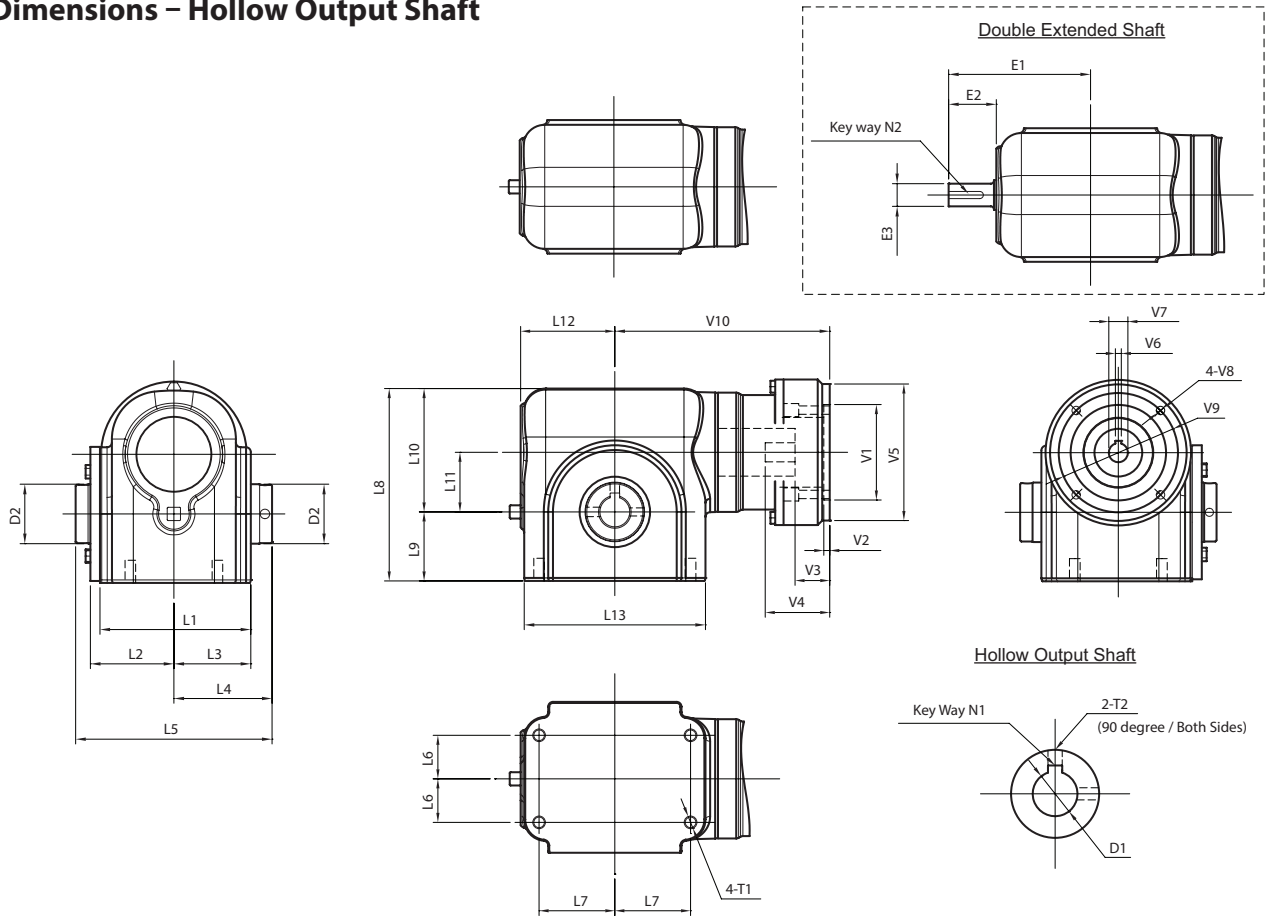

Frame Size	Unit	EJS39	EJS44	EJS50	EJS60	EJS76
L1	[mm]	116.6	121.7	126.5	132.6	172.5
L2	[mm]	65.0	67.6	70.1	72.9	95.0
L3	[mm]	59.4	62.2	64.5	67.6	87.4
L4	[mm]	77.2	79.8	82.3	85.3	109.7
L5	[mm]	154.7	159.8	164.6	170.7	219.5
L6	[mm]	34.9	34.9	36.4	36.4	50.8
L7	[mm]	53.1	53.1	63.5	63.5	88.9
L8	[mm]	138.4	148.3	161.3	177.3	229.6
L9	[mm]	48.5	52.3	57.9	64.0	82.6
L10	[mm]	89.9	96.0	103.4	113.3	147.1
L11	[mm]	39.1	44.5	50.0	59.7	76.2
L12	[mm]	72.4	78.0	79.0	87.4	115.6
L13	[mm]	140.0	151.9	151.9	156.0	210.1
D1	[mm]	φ19	φ20	φ25	φ28	φ35
D2	[mm]	φ40	φ45	φ50	φ55	φ75
Key way N1	[mm]	6.0x3.0	6.0x3.0	8.0x4.0	8.0x4.0	10x4.4
T1	[mm]	M8x12	M8x12	M10x15	M10x15	M12x19.5
T2	[mm]	5/16-24	5/16-24	5/16-24	5/16-24	5/16-24
E1	[mm]	117.1	123.4	126.5	134.1	193.8
E2	[mm]	44.7	45.5	47.5	46.7	78.2
E3	[Inch]	0.75	0.75	0.75	0.75	1.19
Key way N2	[Inch]	3/16x3/32	3/16x3/32	3/16x3/32	3/16x3/32	1/8x1/4
V1 ~ V10	Motor attachment dimensions are made to fit your servo motor.					

EJS Dimensions – Solid Output Shaft

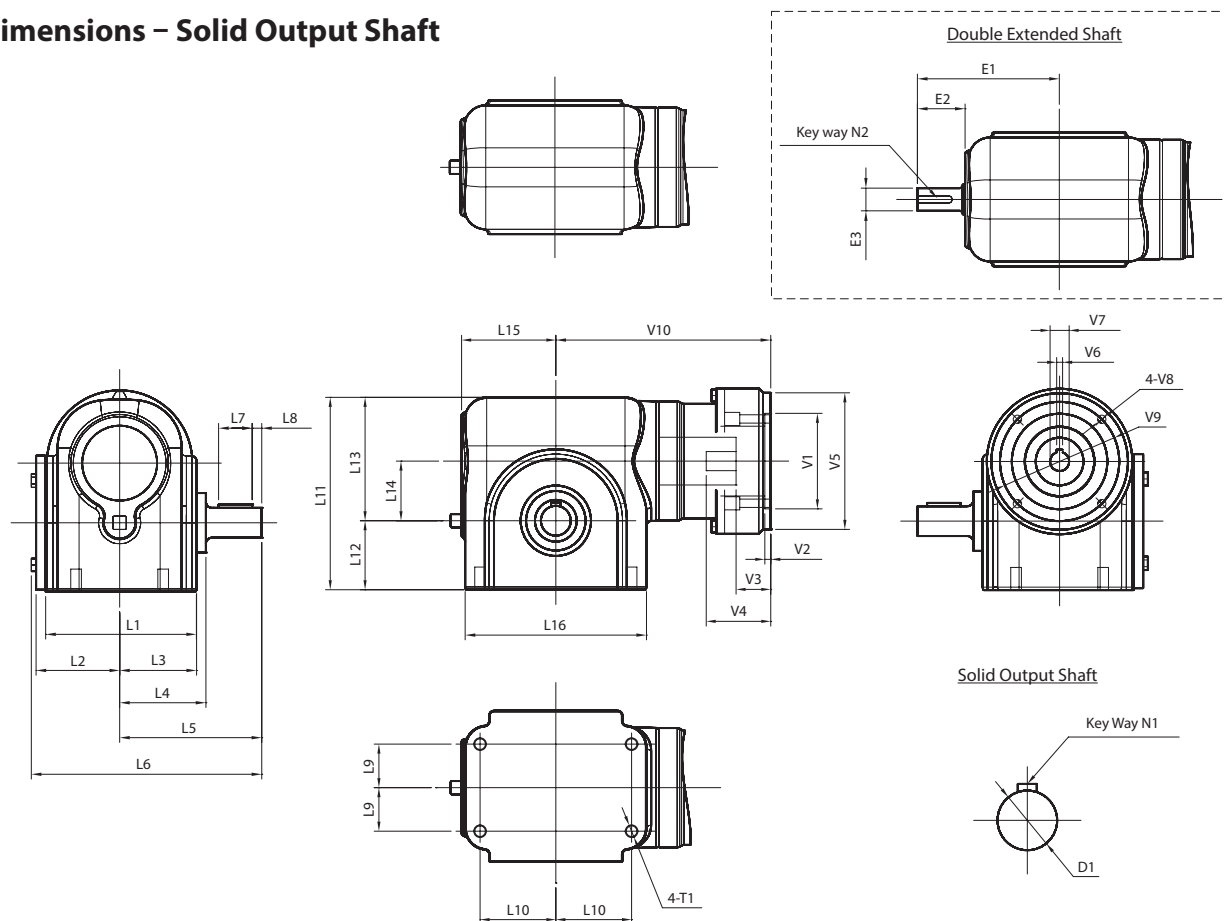

Frame Size	Unit	EJS39	EJS44	EJS50	EJS60	EJS76
L1	[mm]	116.6	121.7	126.5	132.6	172.5
L2	[mm]	65.0	67.6	70.1	72.9	95.0
L3	[mm]	59.4	62.2	64.5	67.6	87.4
L4	[mm]	67.3	69.9	72.4	69.6	100.1
L5	[mm]	109.5	109.5	119.1	129.3	174.0
L6	[mm]	178.6	181.1	193.3	206.2	274.3
L7	[mm]	22	22	28	32	40
L8	[mm]	7	7	8	8	10
L9	[mm]	34.9	34.9	36.4	36.4	50.8
L10	[mm]	53.2	53.2	63.5	63.5	88.9
L11	[mm]	138.4	148.3	161.3	177.3	229.6
L12	[mm]	48.5	52.3	57.9	64.0	82.6
L13	[mm]	89.9	96.0	103.4	113.3	147.1
L14	[mm]	39.1	44.5	50.0	59.7	76.2
L15	[mm]	72.4	78.0	79.0	87.4	115.6
L16	[mm]	140.0	151.9	151.9	156.0	210.1
D1	[mm]	φ18	φ20	φ25	φ28	φ35
Key way N1	[mm]	6.0x3.0	6.0x3.0	8.0x4.0	8.0x4.0	10x4.4
T1	[mm]	M8x12	M8x12	M10x15	M10x15	M12x19.5
E1	[mm]	117.1	123.4	126.5	134.1	193.8
E2	[mm]	44.7	45.5	47.5	46.7	78.2
E3	[mm]	0.75	0.75	0.75	0.75	1.19
Key way N2	[Inch]	3/16x3/32	3/16x3/32	3/16x3/32	3/16x3/32	1/8x1/4
V1 ~ V10	Motor attachment dimensions are made to fit your servo motor.					

EJS SERIES Right-angle Worm

EJS Dimensions – Shrink Disc Hollow Output Shaft

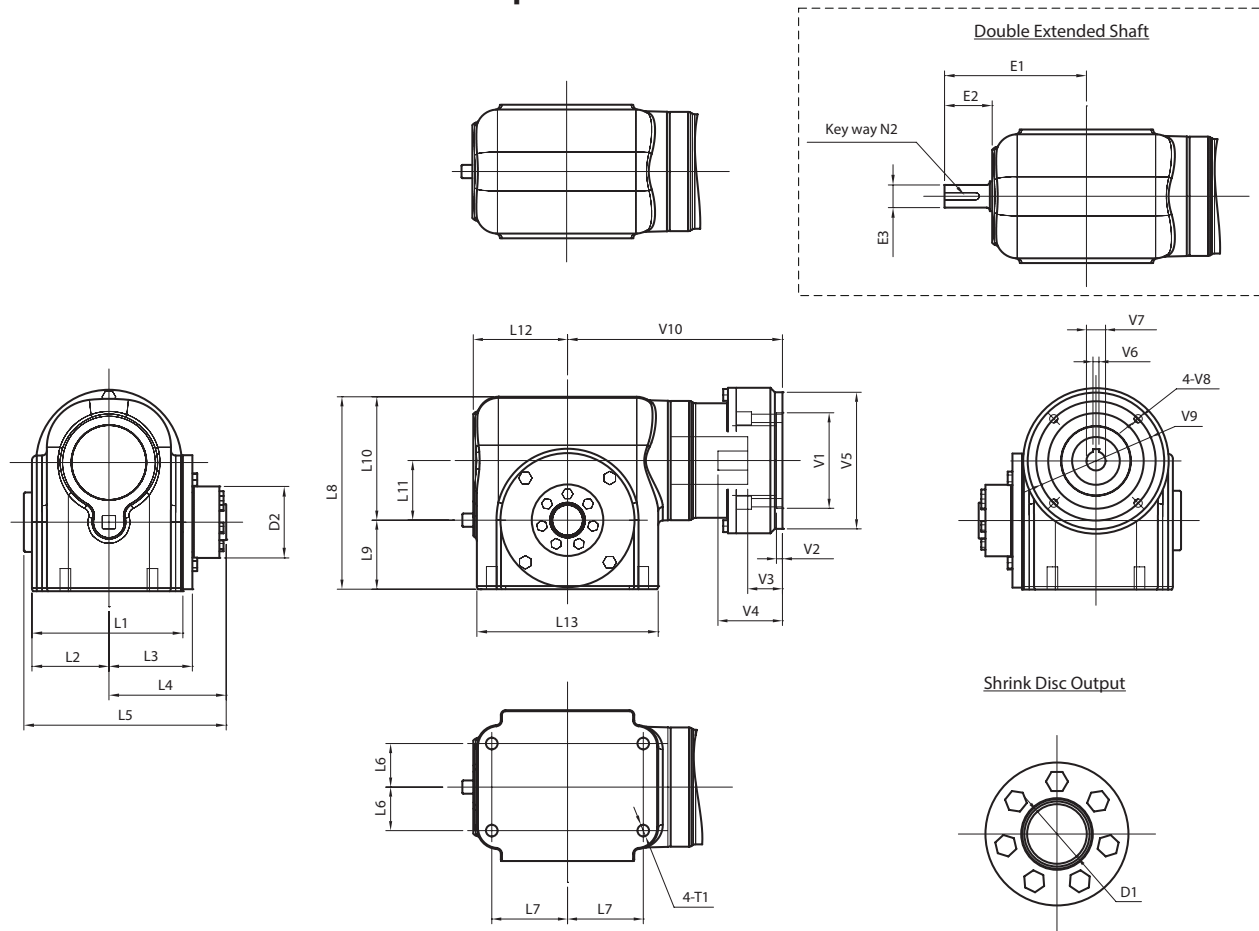

Frame Size	Units	EJS39	EJS44	EJS50	EJS60	EJS76
L1	[mm]	116.6	121.7	126.5	132.6	172.5
L2	[mm]	65.0	67.6	70.1	72.9	95.0
L3	[mm]	59.4	62.2	64.5	67.6	87.4
L4	[mm]	93.2	95.8	98.3	102.9	128.5
L5	[mm]	159.5	164.6	169.7	177.3	226.1
L6	[mm]	34.9	34.9	36.4	36.4	50.8
L7	[mm]	53.2	53.2	63.5	63.5	88.9
L8	[mm]	138.4	148.3	161.3	177.3	229.6
L9	[mm]	48.5	52.3	57.9	64.0	82.6
L10	[mm]	89.9	96.0	103.4	113.3	147.1
L11	[mm]	39.1	44.5	50.0	59.7	76.2
L12	[mm]	72.4	78.0	79.0	87.4	115.6
L13	[mm]	140.0	151.9	151.9	156.0	210.1
D1	[mm]	φ25/φ25.008	φ25/φ25.008	φ25/φ25.008	φ30/φ30.008	φ35.002/φ35.018
D2	[mm]	φ60	φ60	φ60	φ72	φ80
T1	[mm]	M8x12	M8x12	M10x15	M10x15	M12x19.5
E1	[mm]	117.1	123.4	126.5	134.1	193.8
E2	[mm]	44.7	45.5	47.5	46.7	78.2
E3	[mm]	0.75	0.75	0.75	0.75	1.19
Key way N2	[Inch]	3/16x3/32	3/16x3/32	3/16x3/32	3/16x3/32	1/8x1/4
V1 ~ V10	Motor attachment dimensions are made to fit your servo motor.					

EJS Dimensions – Optional Mounting Flange

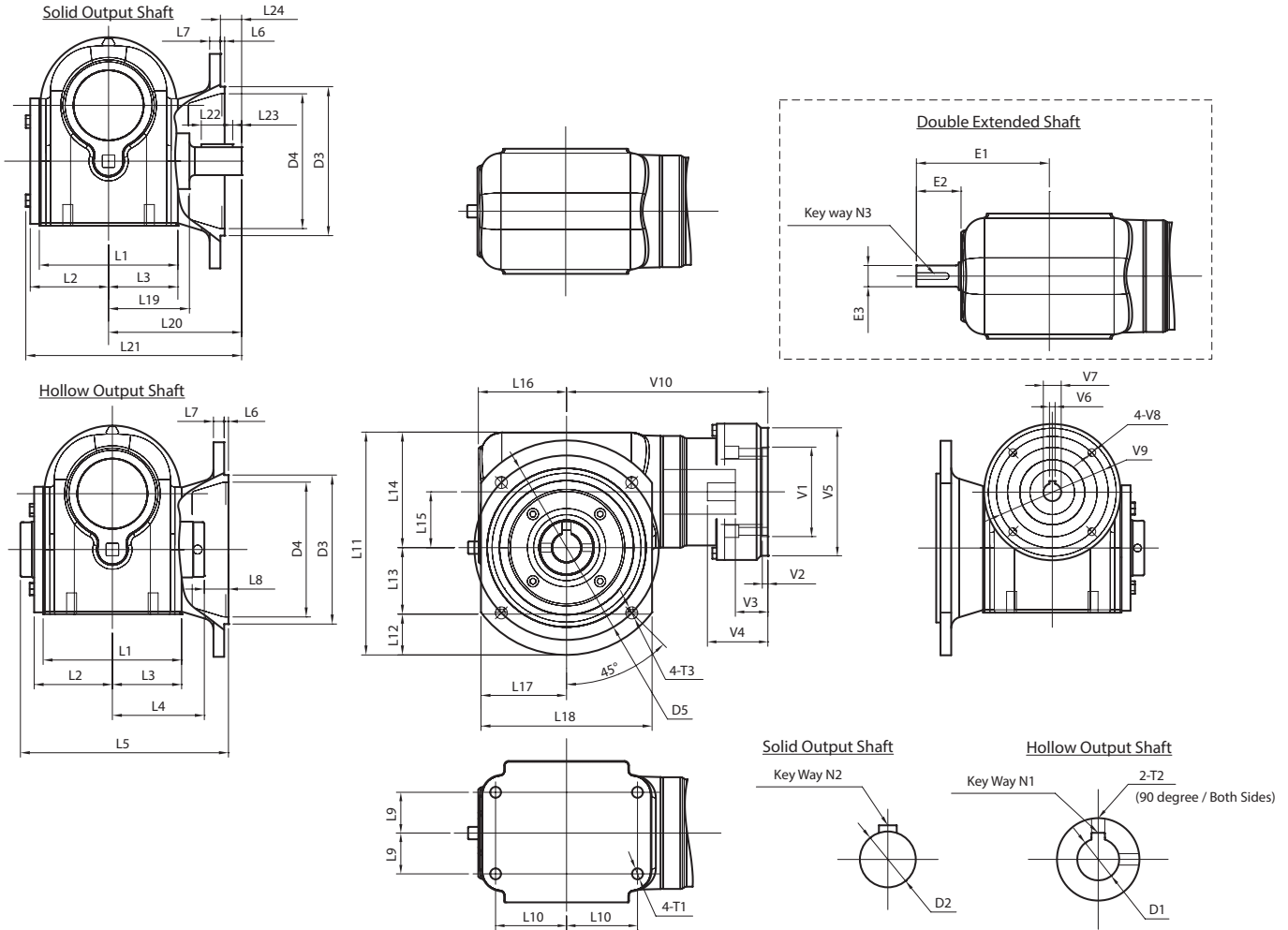

Frame Size	Units	EJS39	EJS44	EJS50	EJS60	EJS76
L1	[mm]	116.6	121.7	126.5	132.6	172.5
L2	[mm]	65.0	67.6	70.1	72.9	95.0
L3	[mm]	59.4	62.2	64.5	67.6	87.4
L4	[mm]	77.2	79.8	82.3	85.3	109.7
L5	[mm]	170	176	186	202	253
L6	[mm]	3.8	3.8	3.8	3.8	3.8
L7	[mm]	9.7	9.7	9.7	9.7	9.7
L8	[mm]	15.7	16.0	21.6	31.5	33.8
L9	[mm]	34.9	34.9	36.4	36.4	50.8
L10	[mm]	53.2	53.2	63.5	63.5	88.9
L11	[mm]	176.3	184.2	199.4	230.6	290.3
L12	[mm]	39.6	35.8	38.1	51.8	60.7
L13	[mm]	48.5	52.3	57.9	64.0	82.6
L14	[mm]	88.1	96	103.4	115.3	147
L15	[mm]	39.1	44	50.0	59.7	76
L16	[mm]	72.4	78	79.0	87.4	116
L17	[mm]	70	70	76.7	92.5	112
L18	[mm]	140.5	140.5	153.2	185.2	223.3
L19	[mm]	67.3	69.9	72.4	69.6	100.1
L20	[mm]	109.5	109.5	119.1	129.3	174.0

Note: Continue Frame Sizes for Optional Mounting Flange on the next page

EJS SERIES Right-angle Worm

EJS Dimensions – Optional Mounting Flange

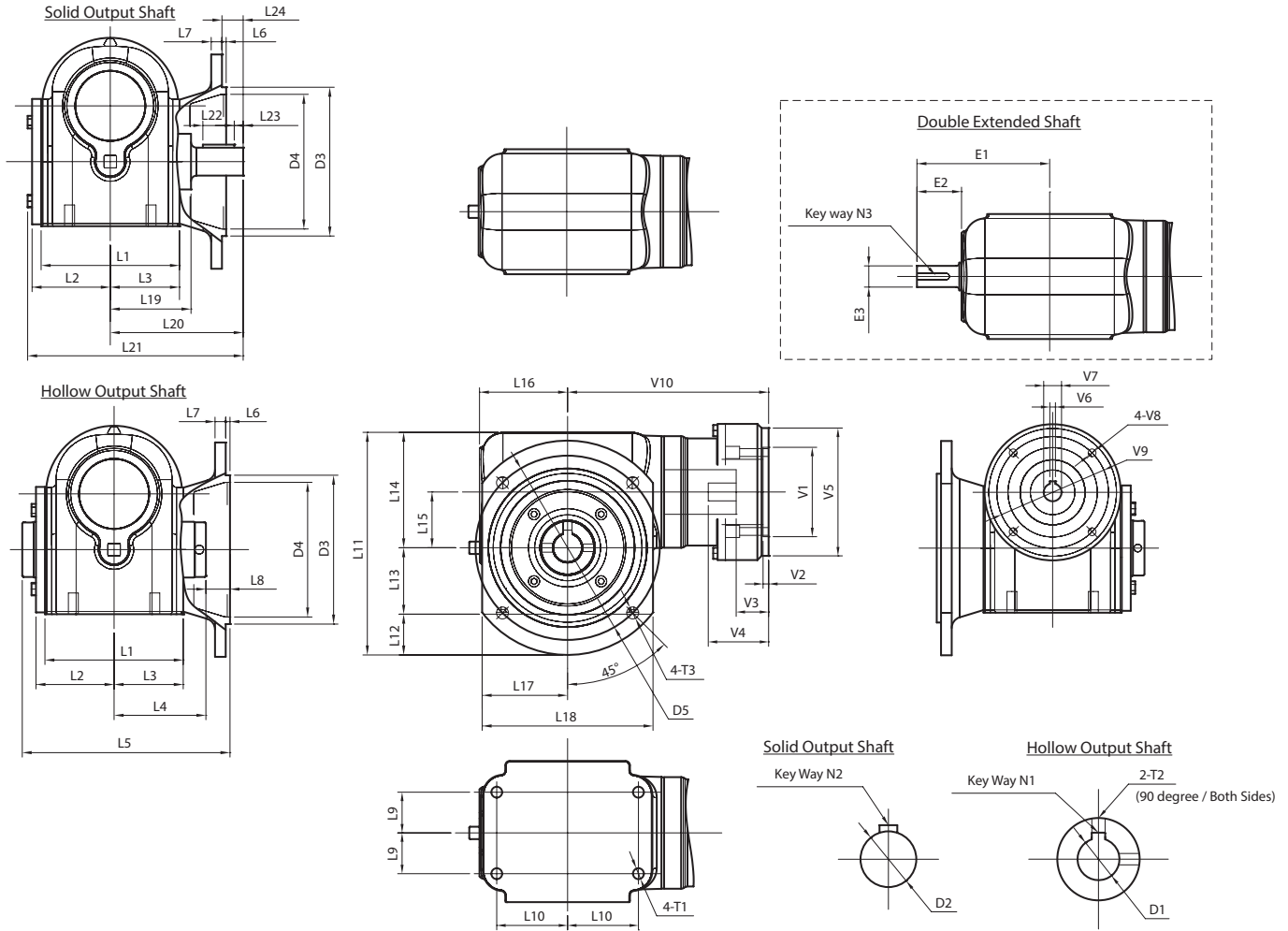

Frame Size	Units	EJS39	EJS44	EJS50	EJS60	EJS76
L21	[mm]	178.6	181.1	193.3	206.2	274.3
L22	[mm]	22	22	28	32	40
L23	[mm]	7	7	8	8	10
L24	[mm]	20.1	17.5	19.1	16.3	34.3
T1	[mm]	M8x12	M8x12	M10x15	M10x15	M12x19.5
D1	[mm]	φ19	φ20	φ25	φ28	φ35
Key way N1	[mm]	6.0x3.0	6.0x3.0	8.0x4.0	8.0x4.0	10x4.4
T2	[mm]	5/16-24	5/16-24	5/16-24	5/16-24	5/16-24
D2	[mm]	φ18	φ20	φ25	φ28	φ35
Key way N2	[mm]	6.0x3.0	6.0x3.0	8.0x4.0	8.0x4.0	10x4.4
D3	[mm]	φ114.3	φ114.3	φ133.4	φ165.1	φ203.2
D4	[mm]	φ103.1	φ103.1	φ120.7	φ142.7	φ182.6
D5	[mm]	φ149.35	φ149.35	φ165.1	φ203.2	φ254
T3	[mm]	9.2	9.2	9.2	9.2	9.2
E1	[mm]	117.1	123.4	126.5	134.1	193.8
E2	[mm]	44.7	45.5	47.5	46.7	78.2
E3	[mm]	0.75	0.75	0.75	0.75	1.19
Key way N3	[Inch]	3/16x3/32	3/16x3/32	3/16x3/32	3/16x3/32	1/8x1/4
V1 ~ V10	Motor attachment dimensions are made to fit your servo motor.					

EJS Dimensions – Side Mount (w/o Flange Mounting)

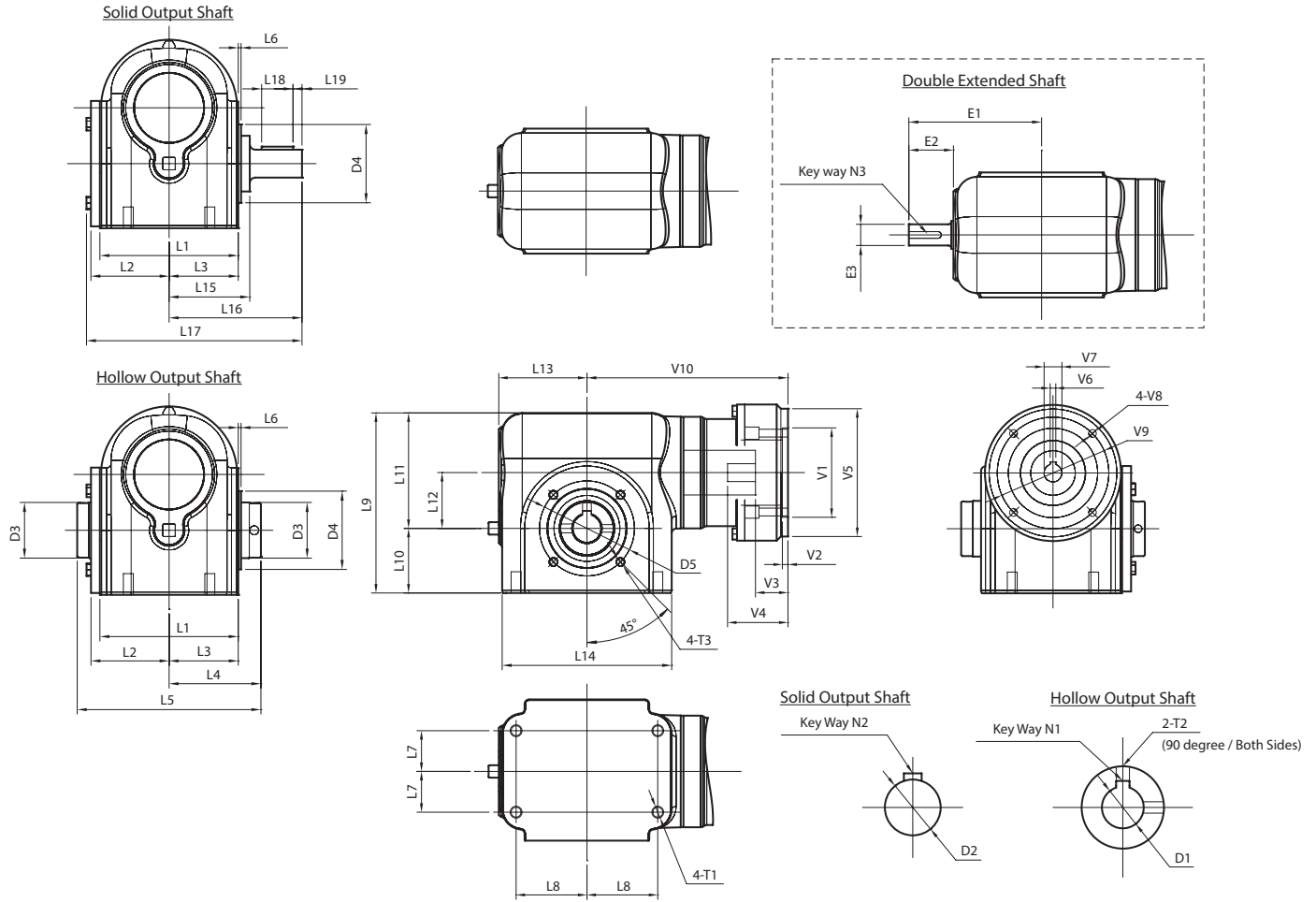

Frame Size	Units	EJS39	EJS44	EJS50	EJS60	EJS76
L1	[mm]	116.6	121.7	126.5	132.6	172.5
L2	[mm]	65.0	67.6	70.1	72.9	95.0
L3	[mm]	59.4	62.2	64.5	67.6	87.4
L4	[mm]	77.2	79.8	82.3	85.3	109.7
L5	[mm]	154.7	159.8	164.6	170.7	219.5
L6	[mm]	2.5	2.5	2.5	2.5	2.5
L7	[mm]	34.9	34.9	36.4	36.4	50.8
L8	[mm]	53.2	53.2	63.5	63.5	88.9
L9	[mm]	138.4	148.3	161.3	177.3	229.6
L10	[mm]	48.5	52.3	57.9	64.0	82.6
L11	[mm]	89.9	96.0	103.4	113.3	147.1
L12	[mm]	39.1	44.5	50.0	59.7	76.2
L13	[mm]	72.4	78.0	79.0	87.4	115.6
L14	[mm]	140.0	151.9	151.9	156.0	210.1
L15	[mm]	67.3	69.9	72.4	69.6	100.1
L16	[mm]	109.5	109.5	119.1	129.3	174.0
L17	[mm]	178.6	181.1	193.3	206.2	274.3

Note: Continue Frame Sizes for Side Mount (w/o Flange Mounting) on the next page

EJS SERIES Right-angle Worm

EJS Dimensions – Side Mount (w/o Flange Mounting)

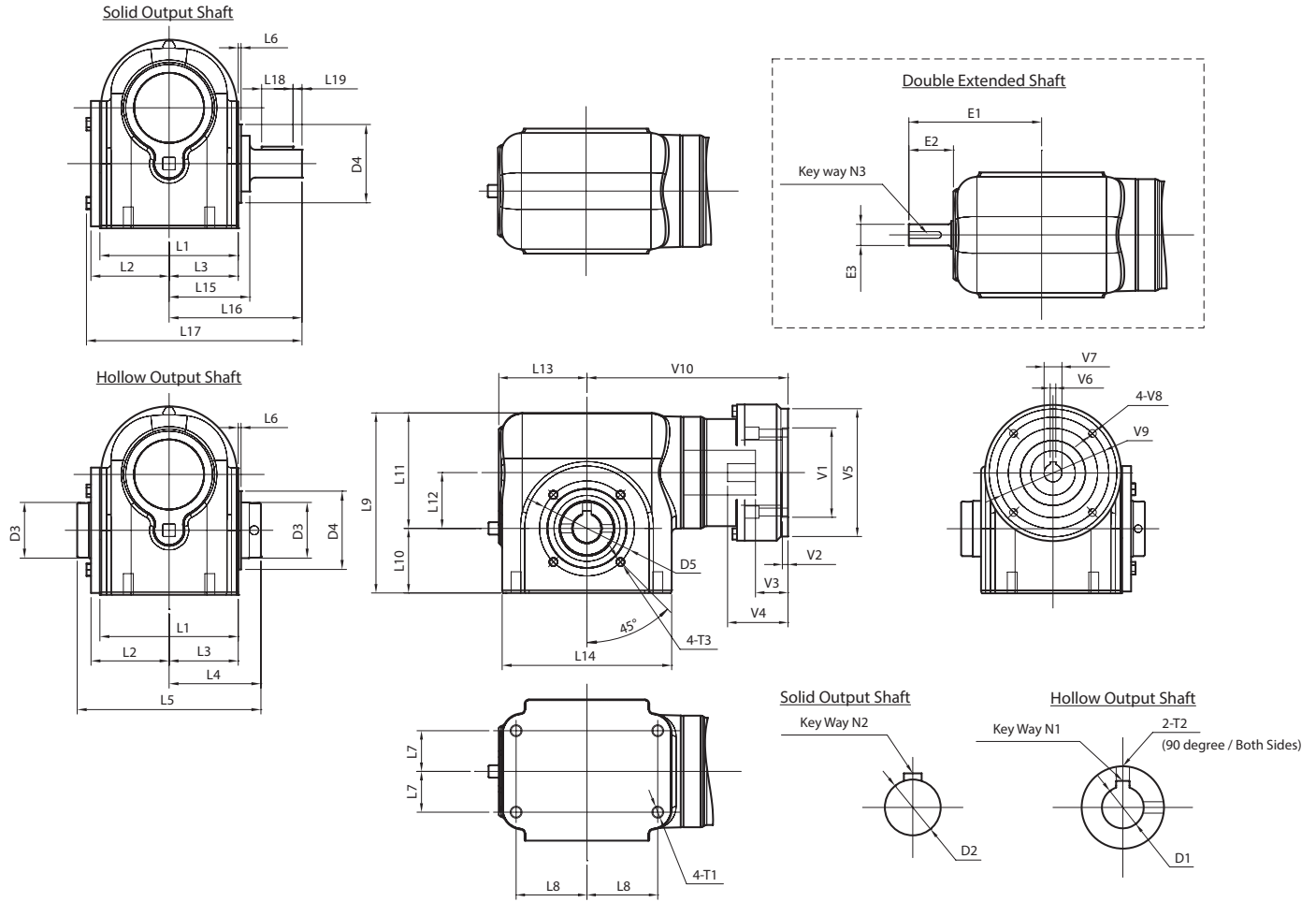

Frame Size	Units	EJS39	EJS44	EJS50	EJS60	EJS76
L18	[Inch]	22	22	28	32	40
L19	[mm]	7	7	8	8	10
T1	[mm]	M8x12	M8x12	M10x15	M10x15	M12x19.5
D1	[mm]	φ19	φ20	φ25	φ28	φ35
Key way N1	[mm]	6.0x3.0	6.0x3.0	8.0x4.0	8.0x4.0	10x4.4
T2	[mm]	5/16-24	5/16-24	5/16-24	5/16-24	5/16-24
D2	[mm]	φ18	φ20	φ25	φ28	φ35
Key way N2	[mm]	6.0x3.0	6.0x3.0	8.0x4.0	8.0x4.0	10x4.4
D3	[mm]	φ40	φ45	φ50	φ55	φ75
D4	[Inch]	φ60	φ70	φ70	φ80	φ110
D5	[mm]	φ75	φ85	φ85	φ95	φ130
T3	[mm]	M6x10	M8x12	M8x12	M8x12	M10x16
E1	[mm]	117.1	123.4	126.5	134.1	193.8
E2	[mm]	44.7	45.5	47.5	46.7	78.2
E3	[Inch]	0.75	0.75	0.75	0.75	1.19
Key way N3	[Inch]	3/16x3/32	3/16x3/32	3/16x3/32	3/16x3/32	1/8x1/4
V1 ~ V10	Motor attachment dimensions are made to fit your servo motor.					