

EJP SERIES

The EJP series is ideal for demanding applications requiring high efficiency, torsional rigidity and zero backlash. It's lightweight, black anodized aluminum housing and dual input/output seals allow for excellent environmental protection with minimal maintenance. The EJP is part of our modular design platform, which means it can be mounted to any servomotor manufacturer with ease.

Our internal design captures both sides of the gear tooth to completely eliminate backlash and guarantee it for the life of the product. Exact reduction ratios allow for simplified servo tuning. Ratios 5:1 through 60:1 are available in a single stage, resulting in a more compact design. The face mounting option gives customers the ability to directly attach components such as tables, pinion gears and timing belt pulleys, eliminating the need for couplings.

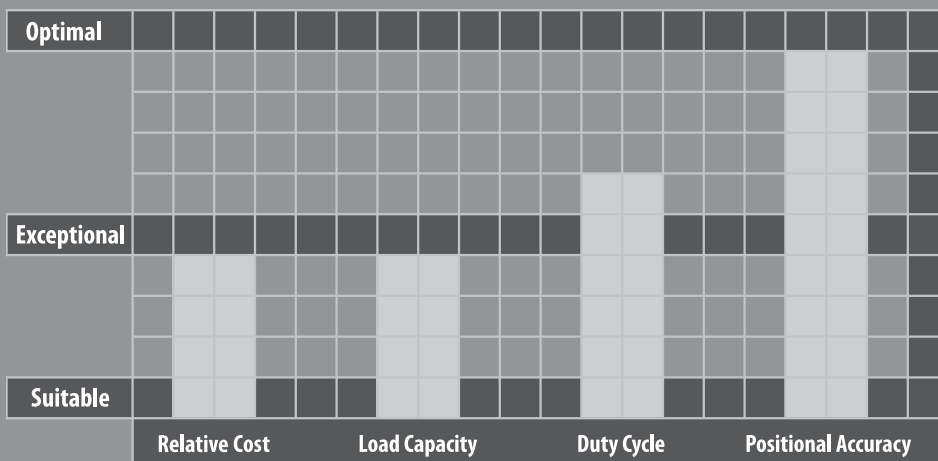



EJP SERIES

- Performance leader in its category
- High positional accuracy and torsional rigidity combined with low noise and exceptionally smooth operation. Zero backlash available
- Wide range of output mounting options
- Compact design – up to 60:1 available in a single stage configuration

EJP SERIES Right-angle Worm

EJP Series Features

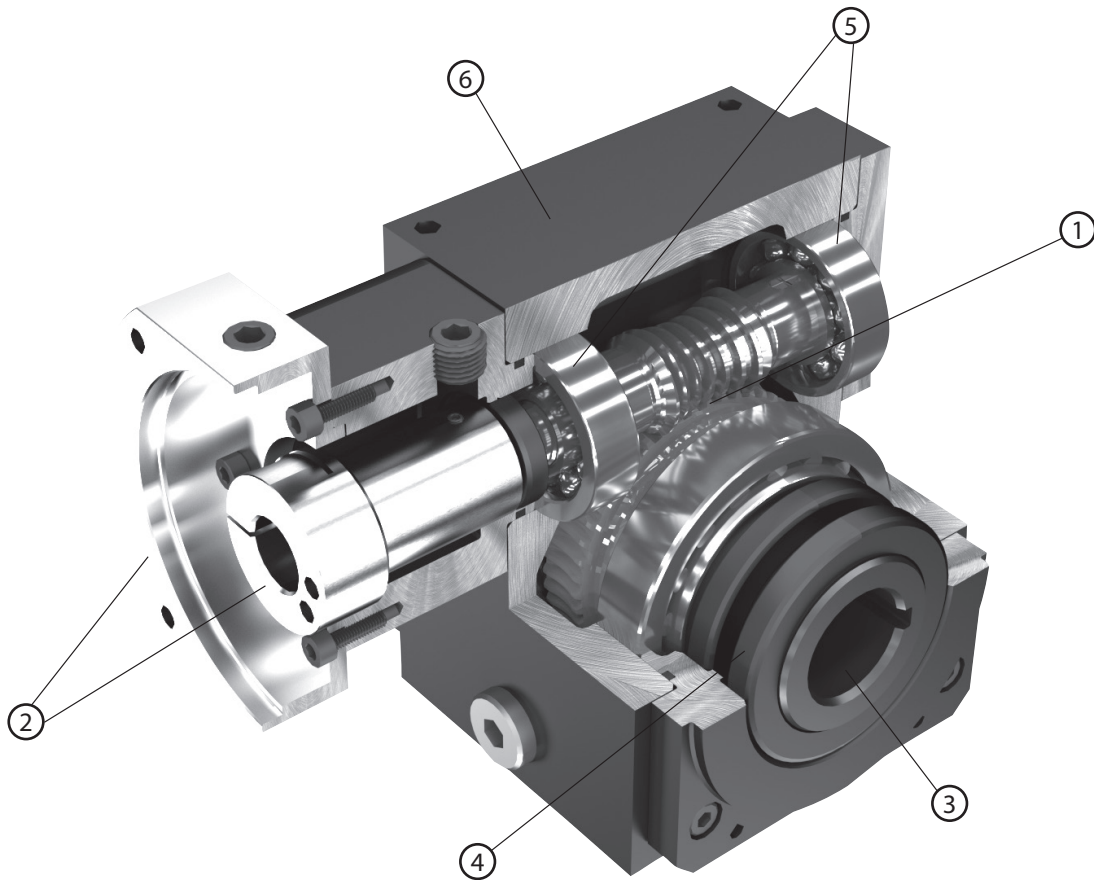

- ① Globoidal gear set – between 3-8 teeth in contact at once, allowing 300% shock load capacity
- ② Adapter-bushing connection allows simple mounting to virtually any servomotor manufacturer
- ③ Wide range of output mounting styles available – hollow shaft, solid shaft, face mount, shrink disc
- ④ Double oil seal and o-ring provide IP65 protection
- ⑤ Ball bearings help reduce friction and heat
- ⑥ Anodized, thermally efficient aluminum housing

EJP Series Model Code

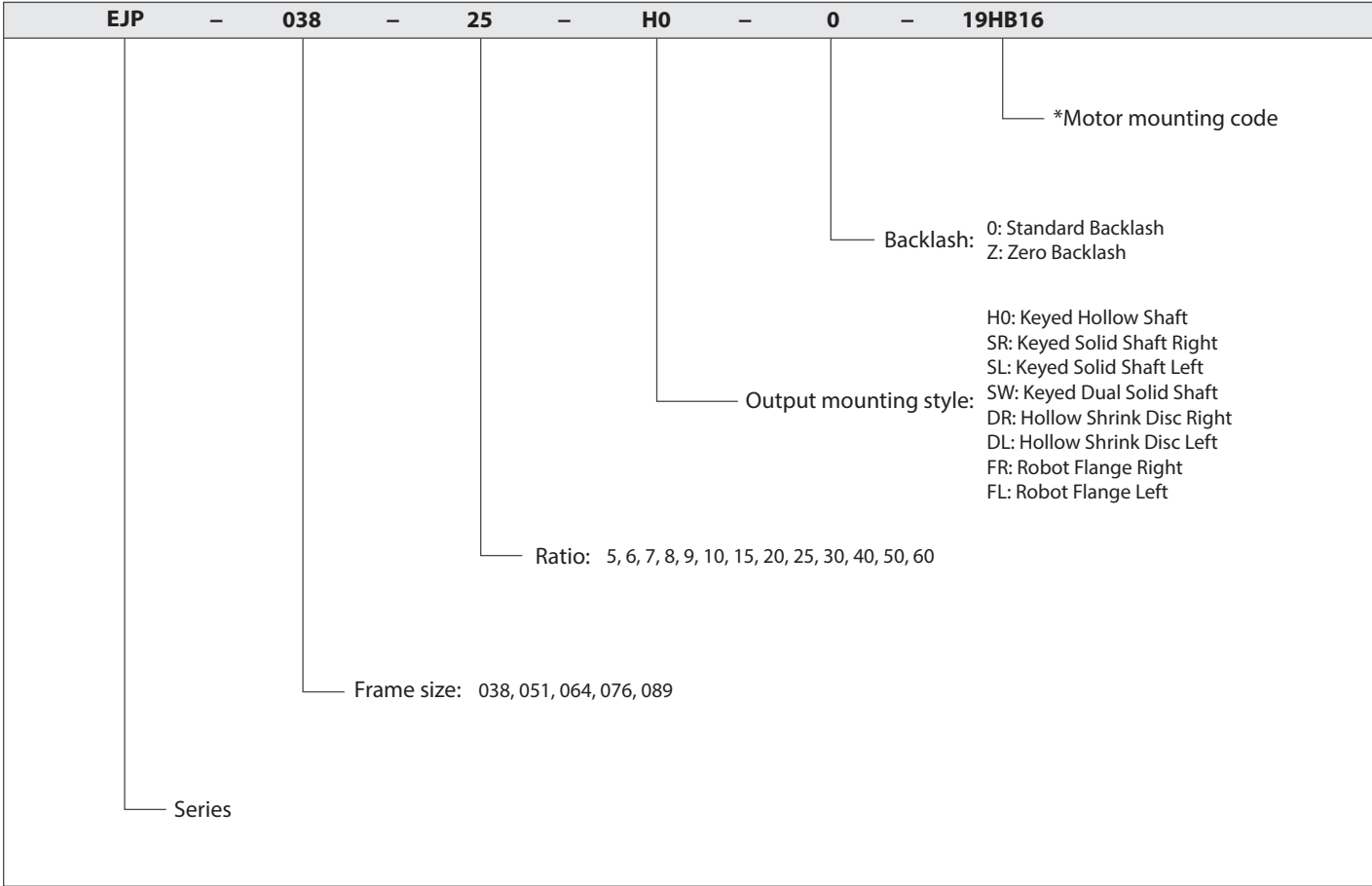

* Motor mounting code varies depending on the motor. Contact us to configure the code.

EJP 038 1-Stage Specifications

Frame Size	038								
Ratio	Unit	Note	5	6	7	8	9	10	15
Nominal Output Torque	[Nm]	--	35	---	---	---	---	46	49
Maximum Acceleration Torque	[Nm]	--	46	---	---	---	---	59	61
Emergency Stop Torque	[Nm]	--	105	---	---	---	---	138	147
No Load Running Torque	[Nm]	*1	0.51						
Nominal Input Speed	[rpm]	--	2,000						
Maximum Continuous Input Speed	[rpm]	--	4,000						
Maximum Cyclic Input Speed	[rpm]	--	6,000						
Maximum Radial Load	[N]	*2	3,110						
Maximum Axial Load	[N]	*3	1,780						
Moment of Inertia ($\leq \varnothing 14$)	[kgcm ²]	--	0.75	---	---	---	---	0.59	0.56
Moment of Inertia ($\leq \varnothing 19$)	[kgcm ²]	--	0.95	---	---	---	---	0.79	0.76
Moment of Inertia ($\leq \varnothing 28$)	[kgcm ²]	--	2.13	---	---	---	---	1.97	1.94
Efficiency	[%]	*4	88	---	---	---	---	86	84
Torsional Rigidity	[Nm/arcmin]	--	3.8						
Maximum Torsional Backlash (Standard)	[Arc-min]	--	≤ 8						
Noise Level	dB [A]	*5	≤ 73						
Ambient Temperature	[°C]	--	-25 ~ 100						
Permitted Housing Temperature	[°C]	--	100						
Protection Class	--	--	IP65						
Lubrication	--	--	Synthetic Oil						
Service Life	[Hours]	--	25,000						
Weight	[kg]	*6	4.1						

*1) Torque at no load applied to the input shaft at 2,000 rpm

*2) The maximum radial load the gearbox can accept

*3) The maximum axial load the gearbox can accept

*4) The efficiency at the nominal output torque rating

*5) Measured with no load applied to the input shaft at 2,000 rpm

*6) Weight may vary slightly between models

EJP 038 1-Stage Specifications

Frame Size	038							
Ratio	Unit	Note	20	25	30	40	50	60
Nominal Output Torque	[Nm]	--	47	---	46	42	42	38
Maximum Acceleration Torque	[Nm]	--	60	---	56	52	52	47
Emergency Stop Torque	[Nm]	--	141	---	138	126	126	114
No Load Running Torque	[Nm]	*1	0.51					
Nominal Input Speed	[rpm]	--	2,000					
Maximum Continuous Input Speed	[rpm]	--	4,000					
Maximum Cyclic Input Speed	[rpm]	--	6,000					
Maximum Radial Load	[N]	*2	3,110					
Maximum Axial Load	[N]	*3	1,780					
Moment of Inertia ($\leq \varnothing 14$)	[kgcm ²]	--	0.54	---	0.54	0.53	0.53	0.53
Moment of Inertia ($\leq \varnothing 19$)	[kgcm ²]	--	0.74	---	0.74	0.73	0.73	0.73
Moment of Inertia ($\leq \varnothing 28$)	[kgcm ²]	--	1.92	---	1.92	1.91	1.91	1.91
Efficiency	[%]	*4	81	---	76	72	69	66
Torsional Rigidity	[Nm/arcmin]	--	3.8					
Maximum Torsional Backlash (Standard)	[Arc-min]	--	≤ 8					
Noise Level	dB [A]	*5	≤ 73					
Ambient Temperature	[°C]	--	-25 ~ 100					
Permitted Housing Temperature	[°C]	--	100					
Protection Class	--	--	IP65					
Lubrication	--	--	Synthetic Oil					
Service Life	[Hours]	--	25,000					
Weight	[kg]	*6	4.1					

*1) Torque at no load applied to the input shaft at 2,000 rpm

*2) The maximum radial load the gearbox can accept

*3) The maximum axial load the gearbox can accept

*4) The efficiency at the nominal output torque rating

*5) Measured with no load applied to the input shaft at 2,000 rpm

*6) Weight may vary slightly between models

EJP 051 1-Stage Specifications

Frame Size	051								
Ratio	Unit	Note	5	6	7	8	9	10	15
Nominal Output Torque	[Nm]	--	67	75	78	82	85	87	90
Maximum Acceleration Torque	[Nm]	--	90	99	110	110	110	120	120
Emergency Stop Torque	[Nm]	--	201	225	234	246	255	261	270
No Load Running Torque	[Nm]	*1	1.61						
Nominal Input Speed	[rpm]	--	2,000						
Maximum Continuous Input Speed	[rpm]	--	4,000						
Maximum Cyclic Input Speed	[rpm]	--	6,000						
Maximum Radial Load	[N]	*2	6,670						
Maximum Axial Load	[N]	*3	1,820						
Moment of Inertia ($\leq \varnothing 14$)	[kgcm ²]	--	1.52	1.28	1.14	1.04	0.98	0.94	0.83
Moment of Inertia ($\leq \varnothing 19$)	[kgcm ²]	--	1.72	1.48	1.34	1.24	1.18	1.14	1.03
Moment of Inertia ($\leq \varnothing 28$)	[kgcm ²]	--	2.89	2.66	2.52	2.42	2.36	2.31	2.21
Efficiency	[%]	*4	92	91	91	91	90	90	88
Torsional Rigidity	[Nm/arcmin]	--	7.6						
Maximum Torsional Backlash (Standard)	[Arc-min]	--	≤ 6						
Maximum Torsional Backlash (Zero)	[Arc-min]	--	≤ 0						
Noise Level	dB [A]	*5	≤ 75						
Ambient Temperature	[°C]	--	-25 ~ 100						
Permitted Housing Temperature	[°C]	--	100						
Protection Class	--	--	IP65						
Lubrication	--	--	Synthetic Oil						
Service Life	[Hours]	--	25,000						
Weight	[kg]	*6	8.2						

*1) Torque at no load applied to the input shaft at 2,000 rpm

*2) The maximum radial load the gearbox can accept

*3) The maximum axial load the gearbox can accept

*4) The efficiency at the nominal output torque rating

*5) Measured with no load applied to the input shaft at 2,000 rpm

*6) Weight may vary slightly between models

EJP 051 1-Stage Specifications

Frame Size	051							
Ratio	Unit	Note	20	25	30	40	50	60
Nominal Output Torque	[Nm]	--	88	89	86	81	78	75
Maximum Acceleration Torque	[Nm]	--	120	120	110	110	100	100
Emergency Stop Torque	[Nm]	--	264	267	258	243	234	225
No Load Running Torque	[Nm]	*1	1.61					
Nominal Input Speed	[rpm]	--	2,000					
Maximum Continuous Input Speed	[rpm]	--	4,000					
Maximum Cyclic Input Speed	[rpm]	--	6,000					
Maximum Radial Load	[N]	*2	6,670					
Maximum Axial Load	[N]	*3	1,820					
Moment of Inertia (≤ Ø14)	[kgcm ²]	--	0.79	0.77	0.76	0.75	0.75	0.75
Moment of Inertia (≤ Ø19)	[kgcm ²]	--	0.99	0.97	0.96	0.95	0.95	0.95
Moment of Inertia (≤ Ø28)	[kgcm ²]	--	2.17	2.15	2.14	2.13	2.13	2.13
Efficiency	[%]	*4	85	84	80	76	73	70
Torsional Rigidity	[Nm/arcmin]	--	7.6					
Maximum Torsional Backlash (Standard)	[Arc-min]	--	≤ 6					
Maximum Torsional Backlash (Zero)	[Arc-min]	--	≤ 0					
Noise Level	dB [A]	*5	≤ 75					
Ambient Temperature	[°C]	--	-25 ~ 100					
Permitted Housing Temperature	[°C]	--	100					
Protection Class	--	--	IP65					
Lubrication	--	--	Synthetic Oil					
Service Life	[Hours]	--	25,000					
Weight	[kg]	*6	8.2					

*1) Torque at no load applied to the input shaft at 2,000 rpm

*2) The maximum radial load the gearbox can accept

*3) The maximum axial load the gearbox can accept

*4) The efficiency at the nominal output torque rating

*5) Measured with no load applied to the input shaft at 2,000 rpm

*6) Weight may vary slightly between models

EJP SERIES Right-angle Worm

EJP 064 1-Stage Specifications

Frame Size	064								
Ratio	Unit	Note	5	6	7	8	9	10	15
Nominal Output Torque	[Nm]	--	120	180	140	150	150	150	160
Maximum Acceleration Torque	[Nm]	--	170	180	190	210	210	210	220
Emergency Stop Torque	[Nm]	--	360	540	420	450	450	450	480
No Load Running Torque	[Nm]	*1	2.72						
Nominal Input Speed	[rpm]	--	2,000						
Maximum Continuous Input Speed	[rpm]	--	4,000						
Maximum Cyclic Input Speed	[rpm]	--	6,000						
Maximum Radial Load	[N]	*2	8,890						
Maximum Axial Load	[N]	*3	1,860						
Moment of Inertia ($\leq \varnothing 19$)	[kgcm ²]	--	5.42	4.66	4.20	3.90	3.69	3.54	3.20
Moment of Inertia ($\leq \varnothing 28$)	[kgcm ²]	--	6.24	5.48	5.02	4.72	4.51	4.36	4.02
Moment of Inertia ($\leq \varnothing 38$)	[kgcm ²]	--	11.8	11.1	10.6	10.3	10.1	9.94	9.60
Efficiency	[%]	*4	92	92	91	91	90	90	88
Torsional Rigidity	[Nm/arcmin]	--	17.5						
Maximum Torsional Backlash (Standard)	[Arc-min]	--	≤ 5						
Maximum Torsional Backlash (Zero)	[Arc-min]	--	≤ 0						
Noise Level	dB [A]	*5	≤ 80						
Ambient Temperature	[°C]	--	-25 ~ 100						
Permitted Housing Temperature	[°C]	--	100						
Protection Class	--	--	IP65						
Lubrication	--	--	Synthetic Oil						
Service Life	[Hours]	--	25,000						
Weight	[kg]	*6	15						

*1) Torque at no load applied to the input shaft at 2,000 rpm

*2) The maximum radial load the gearbox can accept

*3) The maximum axial load the gearbox can accept

*4) The efficiency at the nominal output torque rating

*5) Measured with no load applied to the input shaft at 2,000 rpm

*6) Weight may vary slightly between models

EJP 064 1-Stage Specifications

Frame Size	064							
Ratio	Unit	Note	20	25	30	40	50	60
Nominal Output Torque	[Nm]	--	160	160	150	150	140	130
Maximum Acceleration Torque	[Nm]	--	220	220	210	200	190	180
Emergency Stop Torque	[Nm]	--	480	480	450	450	420	390
No Load Running Torque	[Nm]	*1	2.72					
Nominal Input Speed	[rpm]	--	2,000					
Maximum Continuous Input Speed	[rpm]	--	4,000					
Maximum Cyclic Input Speed	[rpm]	--	6,000					
Maximum Radial Load	[N]	*2	8,890					
Maximum Axial Load	[N]	*3	1,860					
Moment of Inertia (≤ Ø19)	[kgcm ²]	--	3.07	3.02	2.99	2.96	2.94	2.93
Moment of Inertia (≤ Ø28)	[kgcm ²]	--	3.89	3.84	3.81	3.78	3.76	3.75
Moment of Inertia (≤ Ø38)	[kgcm ²]	--	9.47	9.42	9.39	9.36	9.34	9.33
Efficiency	[%]	*4	85	84	80	76	73	70
Torsional Rigidity	[Nm/arcmin]	--	17.5					
Maximum Torsional Backlash (Standard)	[Arc-min]	--	≤ 5					
Maximum Torsional Backlash (Zero)	[Arc-min]	--	≤ 0					
Noise Level	dB [A]	*5	≤ 80					
Ambient Temperature	[°C]	--	-25 ~ 100					
Permitted Housing Temperature	[°C]	--	100					
Protection Class	--	--	IP65					
Lubrication	--	--	Synthetic Oil					
Service Life	[Hours]	--	25,000					
Weight	[kg]	*6	15					

*1) Torque at no load applied to the input shaft at 2,000 rpm

*2) The maximum radial load the gearbox can accept

*3) The maximum axial load the gearbox can accept

*4) The efficiency at the nominal output torque rating

*5) Measured with no load applied to the input shaft at 2,000 rpm

*6) Weight may vary slightly between models

EJP 076 1-Stage Specifications

Frame Size	076									
Ratio	Unit	Note	5	6	7	8	9	10	15	
Nominal Output Torque	[Nm]	--	200	220	230	250	260	260	270	
Maximum Acceleration Torque	[Nm]	--	270	310	320	340	350	370	380	
Emergency Stop Torque	[Nm]	--	600	660	690	750	780	780	810	
No Load Running Torque	[Nm]	*1	3.46							
Nominal Input Speed	[rpm]	--	2,000							
Maximum Continuous Input Speed	[rpm]	--	4,000							
Maximum Cyclic Input Speed	[rpm]	--	6,000							
Maximum Radial Load	[N]	*2	11,110							
Maximum Axial Load	[N]	*3	4,220							
Moment of Inertia ($\leq \varnothing 19$)	[kgcm ²]	--	13.3	11.1	9.8	8.94	8.35	7.92	6.92	
Moment of Inertia ($\leq \varnothing 28$)	[kgcm ²]	--	16.2	14.0	12.7	11.8	11.2	10.8	9.78	
Moment of Inertia ($\leq \varnothing 38$)	[kgcm ²]	--	19.9	17.7	16.3	15.5	14.9	14.5	13.5	
Efficiency	[%]	*4	92	92	91	91	90	89	88	
Torsional Rigidity	[Nm/arcmin]	--	38.5							
Maximum Torsional Backlash (Standard)	[Arc-min]	--	≤ 4							
Maximum Torsional Backlash (Zero)	[Arc-min]	--	≤ 0							
Noise Level	dB [A]	*5	≤ 80							
Ambient Temperature	[°C]	--	-25 ~ 100							
Permitted Housing Temperature	[°C]	--	100							
Protection Class	--	--	IP65							
Lubrication	--	--	Synthetic Oil							
Service Life	[Hours]	--	25,000							
Weight	[kg]	*6	25							

*1) Torque at no load applied to the input shaft at 2,000 rpm

*2) The maximum radial load the gearbox can accept

*3) The maximum axial load the gearbox can accept

*4) The efficiency at the nominal output torque rating

*5) Measured with no load applied to the input shaft at 2,000 rpm

*6) Weight may vary slightly between models

EJP 076 1-Stage Specifications

Frame Size	076							
Ratio	Unit	Note	20	25	30	40	50	60
Nominal Output Torque	[Nm]	--	270	270	260	250	240	230
Maximum Acceleration Torque	[Nm]	--	370	370	360	340	330	320
Emergency Stop Torque	[Nm]	--	810	810	780	750	720	690
No Load Running Torque	[Nm]	*1	3.46					
Nominal Input Speed	[rpm]	--	2,000					
Maximum Continuous Input Speed	[rpm]	--	4,000					
Maximum Cyclic Input Speed	[rpm]	--	6,000					
Maximum Radial Load	[N]	*2	11,110					
Maximum Axial Load	[N]	*3	4,220					
Moment of Inertia (≤ Ø19)	[kgcm ²]	--	6.57	6.41	6.32	6.24	6.19	6.17
Moment of Inertia (≤ Ø28)	[kgcm ²]	--	9.43	9.27	9.18	9.10	9.05	9.03
Moment of Inertia (≤ Ø38)	[kgcm ²]	--	13.1	13.0	12.9	12.8	12.7	12.7
Efficiency	[%]	*4	85	84	80	76	73	70
Torsional Rigidity	[Nm/arcmin]	--	38.5					
Maximum Torsional Backlash (Standard)	[Arc-min]	--	≤ 4					
Maximum Torsional Backlash (Zero)	[Arc-min]	--	≤ 0					
Noise Level	dB [A]	*5	≤ 80					
Ambient Temperature	[°C]	--	-25 ~ 100					
Permitted Housing Temperature	[°C]	--	100					
Protection Class	--	--	IP65					
Lubrication	--	--	Synthetic Oil					
Service Life	[Hours]	--	25,000					
Weight	[kg]	*6	25					

*1) Torque at no load applied to the input shaft at 2,000 rpm

*2) The maximum radial load the gearbox can accept

*3) The maximum axial load the gearbox can accept

*4) The efficiency at the nominal output torque rating

*5) Measured with no load applied to the input shaft at 2,000 rpm

*6) Weight may vary slightly between models

EJP 089 1-Stage Specifications

Frame Size	089									
Ratio	Unit	Note	5	6	7	8	9	10	15	
Nominal Output Torque	[Nm]	--	340	380	400	430	440	460	480	
Maximum Acceleration Torque	[Nm]	--	480	540	570	600	620	640	660	
Emergency Stop Torque	[Nm]	--	1020	1140	1200	1290	1320	1380	1440	
No Load Running Torque	[Nm]	*1							4.20	
Nominal Input Speed	[rpm]	--							2,000	
Maximum Continuous Input Speed	[rpm]	--							4,000	
Maximum Cyclic Input Speed	[rpm]	--							6,000	
Maximum Radial Load	[N]	*2							15,560	
Maximum Axial Load	[N]	*3							4,000	
Moment of Inertia ($\leq \varnothing 19$)	[kgcm ²]	--	28.3	23.9	21.2	19.5	18.3	17.4	15.4	
Moment of Inertia ($\leq \varnothing 28$)	[kgcm ²]	--	32.3	27.8	25.2	23.4	22.2	21.4	19.4	
Moment of Inertia ($\leq \varnothing 38$)	[kgcm ²]	--	36.9	32.5	29.8	28.1	26.9	26.0	24.0	
Efficiency	[%]	*4	91	91	91	90	90	89	87	
Torsional Rigidity	[Nm/arcmin]	--							71	
Maximum Torsional Backlash (Standard)	[Arc-min]	--							≤ 3	
Maximum Torsional Backlash (Zero)	[Arc-min]	--							≤ 0	
Noise Level	dB [A]	*5							≤ 83	
Ambient Temperature	[°C]	--							-25 ~ 100	
Permitted Housing Temperature	[°C]	--							100	
Protection Class	--	--							IP65	
Lubrication	--	--							Synthetic Oil	
Service Life	[Hours]	--							25,000	
Weight	[kg]	*6							50	

*1) Torque at no load applied to the input shaft at 2,000 rpm

*2) The maximum radial load the gearbox can accept

*3) The maximum axial load the gearbox can accept

*4) The efficiency at the nominal output torque rating

*5) Measured with no load applied to the input shaft at 2,000 rpm

*6) Weight may vary slightly between models

EJP 089 1-Stage Specifications

Frame Size	089							
Ratio	Unit	Note	20	25	30	40	50	60
Nominal Output Torque	[Nm]	--	470	470	450	430	410	400
Maximum Acceleration Torque	[Nm]	--	650	650	620	590	570	550
Emergency Stop Torque	[Nm]	--	1410	1410	1350	1290	1230	1200
No Load Running Torque	[Nm]	*1	4.20					
Nominal Input Speed	[rpm]	--	2,000					
Maximum Continuous Input Speed	[rpm]	--	4,000					
Maximum Cyclic Input Speed	[rpm]	--	6,000					
Maximum Radial Load	[N]	*2	15,560					
Maximum Axial Load	[N]	*3	4,000					
Moment of Inertia (≤ Ø19)	[kgcm ²]	--	14.7	14.4	14.2	14.0	13.9	13.9
Moment of Inertia (≤ Ø28)	[kgcm ²]	--	18.7	18.3	18.1	18.0	17.9	17.8
Moment of Inertia (≤ Ø38)	[kgcm ²]	--	23.3	23.0	22.8	22.6	22.5	22.5
Efficiency	[%]	*4	84	83	79	75	72	69
Torsional Rigidity	[Nm/arcmin]	--	71					
Maximum Torsional Backlash (Standard)	[Arc-min]	--	≤ 3					
Maximum Torsional Backlash (Zero)	[Arc-min]	--	≤ 0					
Noise Level	dB [A]	*5	≤ 83					
Ambient Temperature	[°C]	--	-25 ~ 100					
Permitted Housing Temperature	[°C]	--	100					
Protection Class	--	--	IP65					
Lubrication	--	--	Synthetic Oil					
Service Life	[Hours]	--	25,000					
Weight	[kg]	*6	50					

*1) Torque at no load applied to the input shaft at 2,000 rpm

*2) The maximum radial load the gearbox can accept

*3) The maximum axial load the gearbox can accept

*4) The efficiency at the nominal output torque rating

*5) Measured with no load applied to the input shaft at 2,000 rpm

*6) Weight may vary slightly between models

EJP SERIES Right-angle Worm

EJP Dimensions – Hollow Output Shaft

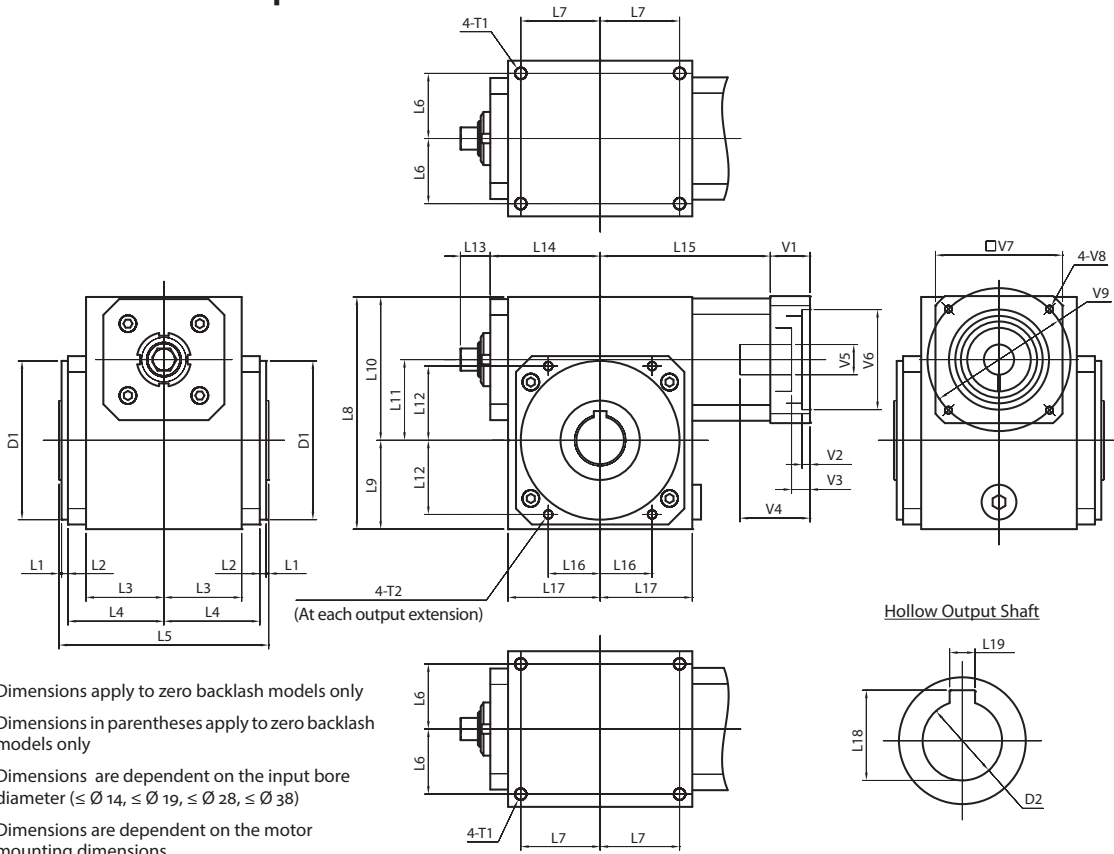

- *1) Dimensions apply to zero backlash models only
- *2) Dimensions in parentheses apply to zero backlash models only
- *3) Dimensions are dependent on the input bore diameter ($\leq \varnothing 14$, $\leq \varnothing 19$, $\leq \varnothing 28$, $\leq \varnothing 38$)
- *4) Dimensions are dependent on the motor mounting dimensions

Frame Size	Unit	Note	EJP-038	EJP-051	EJP-064	EJP-076	EJP-089
L1	[mm]	--	1	1	1	2	2
L2	[mm]	--	4	4	4	4	4
L3	[mm]	--	39	49	54	73.5	90
L4	[mm]	--	51	60.5	70	94	111.5
L5	[mm]	--	112	132	148	200	234
L6	[mm]	--	32	41	44	63	80
L7	[mm]	--	42	50	68.5	79	95
L8	[mm]	--	118	146.5	181	214	252
L9	[mm]	--	45	56	73	82	100
L10	[mm]	--	73	90.5	108	132	152
L11	[mm]	--	38.1	50.8	63.5	76.2	88.9
L12	[mm]	--	34.5	46.5	57.5	64.5	80.5
L13	[mm]	*1	---	22	22	32	35
L14	[mm]	*2	63	69.5 (71)	94 (96)	110 (111)	125.5 (131)
L15	[mm]	*3	96.5 - 106.5	105 - 115	130.5 - 142.5	151 - 163	165 - 177
L16	[mm]	--	18.5	32.5	40	45.5	46.5
L17	[mm]	--	50.5	58	79	89.5	105
L18	[mm]	--	28.5	33.5	38.5	49.0	64.5
L19	[mm]	--	8	8	10	14	18
D1 (h8)	[mm]	--	$\varnothing 64$	$\varnothing 100$	$\varnothing 120$	$\varnothing 134$	$\varnothing 145$
D2 (H7)	[mm]	--	$\varnothing 25$	$\varnothing 30$	$\varnothing 35$	$\varnothing 45$	$\varnothing 60$
T1	[mm]	--	4xM8x12	4xM8x12	4xM8x12	4xM10x15	4xM10x15
T2	[mm]	--	4xM6x9	4xM6x9	4xM8x12	4xM10x15	4xM10x15
V1 ~ V9	[mm]	*4	Motor attachment dimensions are made to fit your servo motor.				

EJP Dimensions – Solid Output Shaft

- *1) Dimensions apply to zero backlash models only
- *2) Dimensions in parentheses apply to zero backlash models only

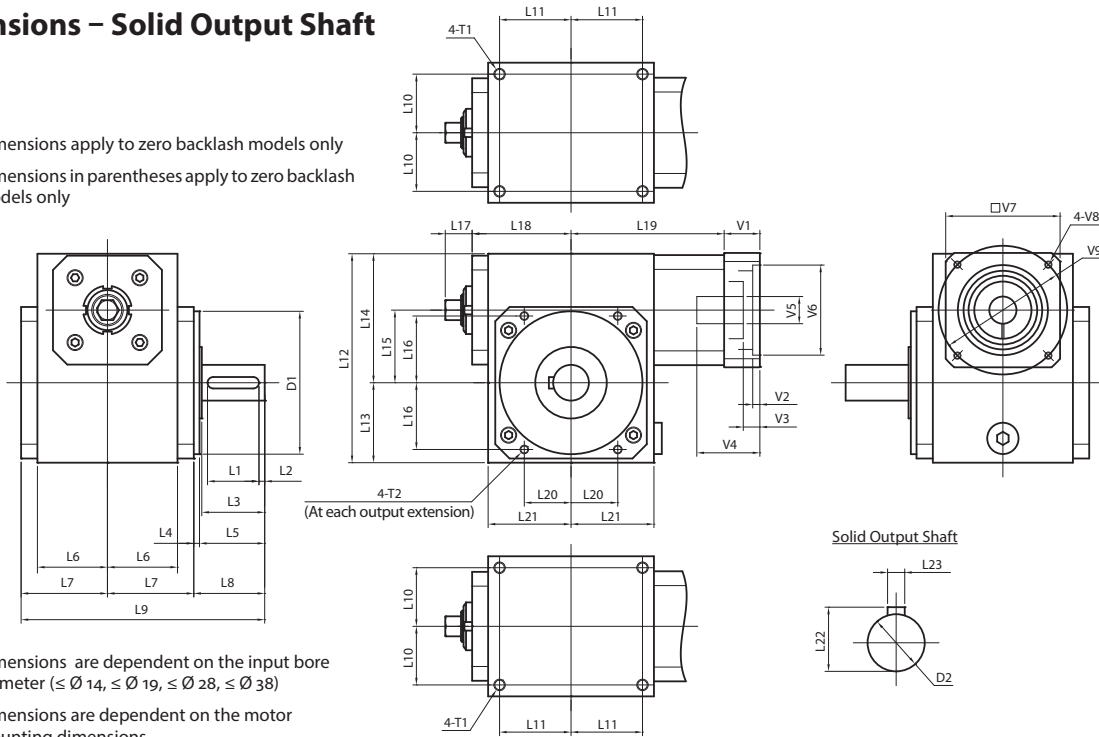

- *3) Dimensions are dependent on the input bore diameter ($\leq \varnothing 14$, $\leq \varnothing 19$, $\leq \varnothing 28$, $\leq \varnothing 38$)
- *4) Dimensions are dependent on the motor mounting dimensions

Frame Size	Unit	Note	EJP-038	EJP-051	EJP-064	EJP-076	EJP-089
L1	[mm]	--	22	36	40	50	63
L2	[mm]	--	90	4	4	5	5
L3	[mm]	--	30	44	50	67	83
L4	[mm]	--	4	4	4	4	4
L5	[mm]	--	31	45.5	51	67	84.5
L6	[mm]	--	39	49	54	73.5	90
L7	[mm]	--	51	60.5	70	94	111
L8	[mm]	--	35	49.5	55	71	88.5
L9	[mm]	--	137	170.5	194	259	311.5
L10	[mm]	--	32	41	44	63	80
L11	[mm]	--	42	50	68.5	79	95
L12	[mm]	--	118	146.5	181	214	252
L13	[mm]	--	45	56	73	82	100
L14	[mm]	--	73	90.5	108	132	152
L15	[mm]	--	38.1	50.8	63.5	76.2	88.9
L16	[mm]	--	34.5	46.5	57.5	64.5	80.5
L17	[mm]	*1	---	22	22	32	35
L18	[mm]	*2	63	69.5 (71)	94 (96)	110 (111)	125.5 (131)
L19	[mm]	*3	96.5 - 106.5	105 - 115	130.5 - 142.5	151 - 163	165 - 177
L20	[mm]	--	18.5	32.5	40	45.5	46.5
L21	[mm]	--	50.5	58	79	89.5	105
L22	[mm]	--	22.5	28	33	38	48.5
L23	[mm]	--	6	8	8	10	14
D1 (h8)	[mm]	--	ø64	ø100	ø120	ø134	ø145
D2 (k6)	[mm]	--	ø20	ø25	ø30	ø35	ø45
T1	[mm]	--	4xM8x12	4xM8x12	4xM8x12	4xM10x15	4xM10x15
T2	[mm]	--	4xM6x9	4xM6x9	4xM8x12	4xM10x15	4xM10x15
V1 ~ V9	[mm]	*4	Motor attachment dimensions are made to fit your servo motor.				

EJP SERIES Right-angle Worm

EJP Dimensions – Flange Output

- *1) Dimensions apply to zero backlash models only
- *2) Dimensions in parentheses apply to zero backlash models only
- *3) Dimensions are dependent on the input bore diameter ($\leq \varnothing 14$, $\leq \varnothing 19$, $\leq \varnothing 28$, $\leq \varnothing 38$)

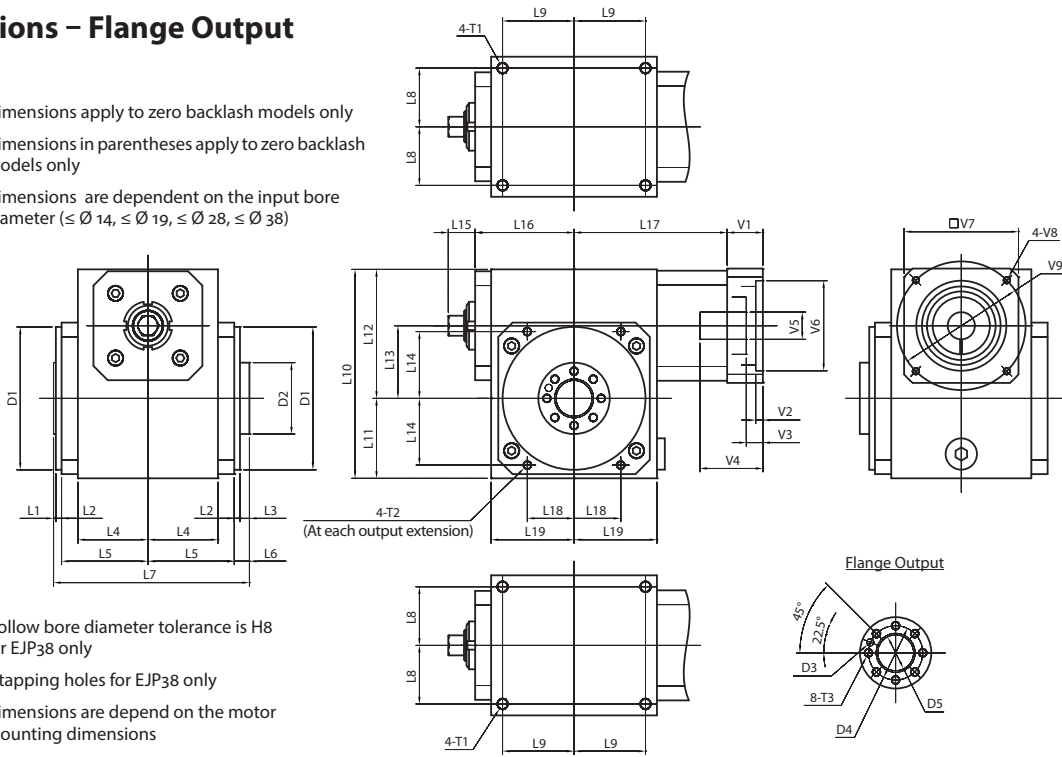

- *4) Hollow bore diameter tolerance is H8 for EJP38 only
- *5) 4 tapping holes for EJP38 only
- *6) Dimensions are depend on the motor mounting dimensions

Frame Size	Unit	Note	EJP-038	EJP-051	EJP-064	EJP-076	EJP-089
L1	[mm]	--	1	1.5	1.5	2	2
L2	[mm]	--	4	4	4	4	4
L3	[mm]	--	6	6.5	6	7	7
L4	[mm]	--	39	49	54	73.5	90
L5	[mm]	--	51	60.5	70	94	111
L6	[mm]	--	10	10.5	10	11	11
L7	[mm]	--	117	137	153	205	239
L8	[mm]	--	32	41	44	63	80
L9	[mm]	--	42	50	68.5	79	95
L10	[mm]	--	118	146.5	181	214	252
L11	[mm]	--	45	56	73	82	100
L12	[mm]	--	73	90.5	108	132	152
L13	[mm]	--	38.1	50.8	63.5	76.2	88.9
L14	[mm]	--	34.5	46.5	57.5	64.5	80.5
L15	[mm]	*1	--	22	22	32	35
L16	[mm]	*2	63	69.5 (71)	94 (96)	110 (111)	125.5 (131)
L17	[mm]	*3	96.5 - 106.5	105 - 115	130.5 - 142.5	151 - 163	165 - 177
L18	[mm]	--	18.5	32.5	40	45.5	46.5
L19	[mm]	--	50.5	58	79	89.5	105
D1 (h8)	[mm]	--	$\varnothing 64$	$\varnothing 100$	$\varnothing 120$	$\varnothing 134$	$\varnothing 145$
D2 (h11)	[mm]	--	$\varnothing 40$	$\varnothing 50$	$\varnothing 65$	$\varnothing 80$	$\varnothing 90$
D3 (H9)	[mm]	--	$\varnothing 5 \times 10$	$\varnothing 5 \times 10$	$\varnothing 6 \times 10$	$\varnothing 8 \times 10$	$\varnothing 8 \times 10$
D4	[mm]	--	$\varnothing 28$	$\varnothing 38$	$\varnothing 50$	$\varnothing 60$	$\varnothing 70$
D5 (H7)	[mm]	*4	$\varnothing 16$	$\varnothing 25$	$\varnothing 30$	$\varnothing 35$	$\varnothing 45$
T1	[mm]	--	4xM8x12	4xM8x12	4xM8x12	4xM10x15	4xM10x15
T2	[mm]	--	4xM6x9	4xM6x9	4xM8x12	4xM10x15	4xM10x15
T3	[mm]	*5	4xM6x12	8xM6x12	8xM8x16	8xM8x16	8xM10x20
V1 ~ V9	[mm]	*6	Motor attachment dimensions are made to fit your servo motor.				

EJP Dimensions – Hollow Output with Shrink Disk

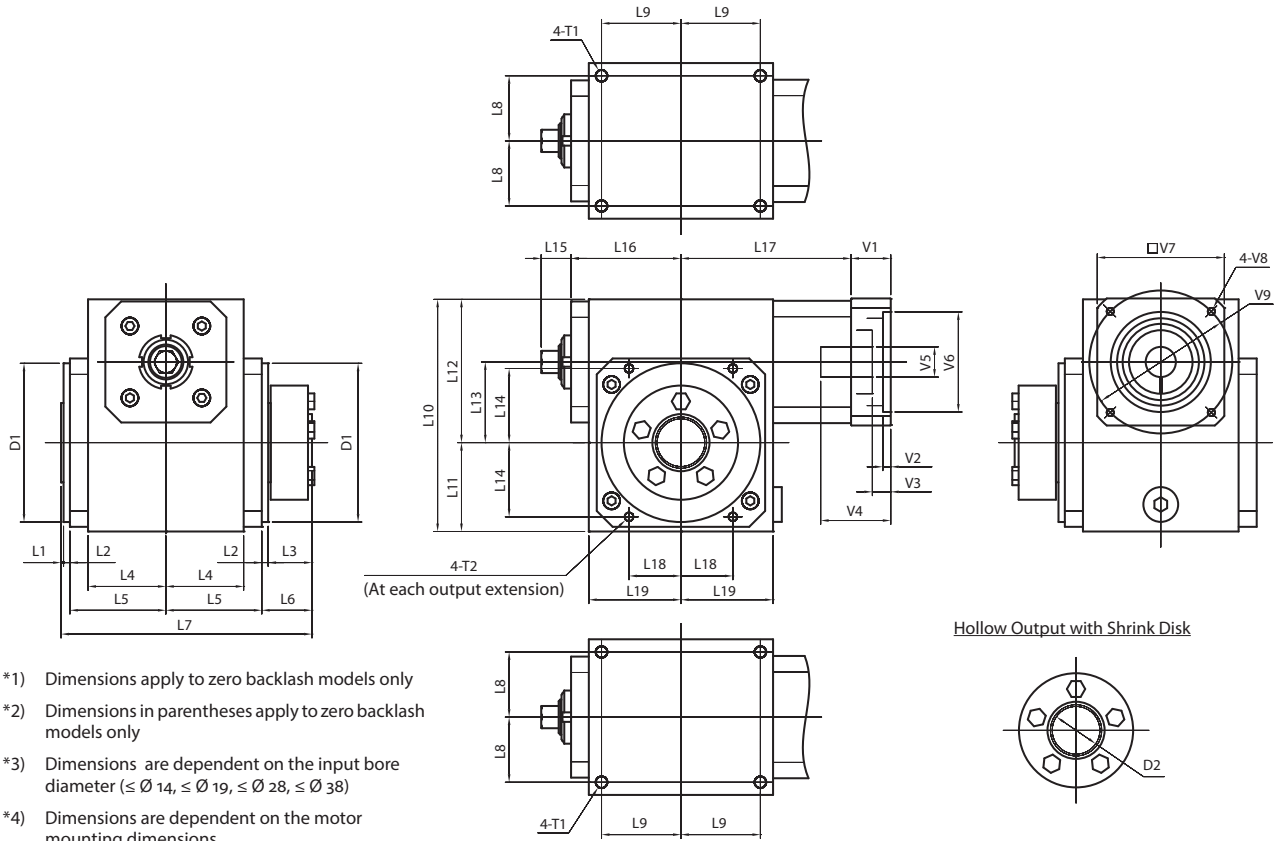

Hollow Output with Shrink Disk

- *1) Dimensions apply to zero backlash models only
- *2) Dimensions in parentheses apply to zero backlash models only
- *3) Dimensions are dependent on the input bore diameter ($\leq \varnothing 14$, $\leq \varnothing 19$, $\leq \varnothing 28$, $\leq \varnothing 38$)
- *4) Dimensions are dependent on the motor mounting dimensions

Frame Size	Unit	Note	EJP-038	EJP-051	EJP-064	EJP-076	EJP-089
L1	[mm]	--	1	1.5	1.5	2	2
L2	[mm]	--	4	4	4	4	4
L3	[mm]	--	25	27.5	36	37	38.5
L4	[mm]	--	39	49	54	73.5	90
L5	[mm]	--	51	60.5	70	94	111
L6	[mm]	--	29	31.5	40	41	42.5
L7	[mm]	--	136	158	183	235	271
L8	[mm]	--	32	41	44	63	80
L9	[mm]	--	42	50	68.5	79	95
L10	[mm]	--	118	146.5	181	214	252
L11	[mm]	--	45	56	73	82	100
L12	[mm]	--	73	90.5	108	132	152
L13	[mm]	--	38.1	50.8	63.5	76.2	88.9
L14	[mm]	--	34.5	46.5	57.5	64.5	80.5
L15	[mm]	*1	---	22	22	32	35
L16	[mm]	*2	63	69.5 (71)	94 (96)	110 (111)	125.5 (131)
L17	[mm]	*3	96.5 - 106.5	105 - 115	130.5 - 142.5	151 - 163	165 - 177
L18	[mm]	--	18.5	32.5	40	45.5	46.5
L19	[mm]	--	50.5	58	79	89.5	105
D1 (h8)	[mm]	--	$\varnothing 64$	$\varnothing 100$	$\varnothing 120$	$\varnothing 134$	$\varnothing 145$
D2 (H6)	[mm]	--	$\varnothing 25$	$\varnothing 30$	$\varnothing 35$	$\varnothing 45$	$\varnothing 60$
T1	[mm]	--	4xM8x12	4xM8x12	4xM8x12	4xM10x15	4xM10x15
T2	[mm]	--	4xM6x9	4xM6x9	4xM8x12	4xM10x15	4xM10x15
V1 ~ V9	[mm]	*4	Motor attachment dimensions are made to fit your servo motor.				