

EJP 076 1-Stage Specifications

Frame Size	076									
Ratio	Unit	Note	5	6	7	8	9	10	15	
Nominal Output Torque	[Nm]	--	200	220	230	250	260	260	270	
Maximum Acceleration Torque	[Nm]	--	270	310	320	340	350	370	380	
Emergency Stop Torque	[Nm]	--	600	660	690	750	780	780	810	
No Load Running Torque	[Nm]	*1	3.46							
Nominal Input Speed	[rpm]	--	2,000							
Maximum Continuous Input Speed	[rpm]	--	4,000							
Maximum Cyclic Input Speed	[rpm]	--	6,000							
Maximum Radial Load	[N]	*2	11,110							
Maximum Axial Load	[N]	*3	4,220							
Moment of Inertia ($\leq \varnothing 19$)	[kgcm ²]	--	13.3	11.1	9.8	8.94	8.35	7.92	6.92	
Moment of Inertia ($\leq \varnothing 28$)	[kgcm ²]	--	16.2	14.0	12.7	11.8	11.2	10.8	9.78	
Moment of Inertia ($\leq \varnothing 38$)	[kgcm ²]	--	19.9	17.7	16.3	15.5	14.9	14.5	13.5	
Efficiency	[%]	*4	92	92	91	91	90	89	88	
Torsional Rigidity	[Nm/arcmin]	--	38.5							
Maximum Torsional Backlash (Standard)	[Arc-min]	--	≤ 4							
Maximum Torsional Backlash (Zero)	[Arc-min]	--	≤ 0							
Noise Level	dB [A]	*5	≤ 80							
Ambient Temperature	[°C]	--	-25 ~ 100							
Permitted Housing Temperature	[°C]	--	100							
Protection Class	--	--	IP65							
Lubrication	--	--	Synthetic Oil							
Service Life	[Hours]	--	25,000							
Weight	[kg]	*6	25							

*1) Torque at no load applied to the input shaft at 2,000 rpm

*2) The maximum radial load the gearbox can accept

*3) The maximum axial load the gearbox can accept

*4) The efficiency at the nominal output torque rating

*5) Measured with no load applied to the input shaft at 2,000 rpm

*6) Weight may vary slightly between models

EJP 076 1-Stage Specifications

Frame Size	076							
Ratio	Unit	Note	20	25	30	40	50	60
Nominal Output Torque	[Nm]	--	270	270	260	250	240	230
Maximum Acceleration Torque	[Nm]	--	370	370	360	340	330	320
Emergency Stop Torque	[Nm]	--	810	810	780	750	720	690
No Load Running Torque	[Nm]	*1	3.46					
Nominal Input Speed	[rpm]	--	2,000					
Maximum Continuous Input Speed	[rpm]	--	4,000					
Maximum Cyclic Input Speed	[rpm]	--	6,000					
Maximum Radial Load	[N]	*2	11,110					
Maximum Axial Load	[N]	*3	4,220					
Moment of Inertia (≤ Ø19)	[kgcm ²]	--	6.57	6.41	6.32	6.24	6.19	6.17
Moment of Inertia (≤ Ø28)	[kgcm ²]	--	9.43	9.27	9.18	9.10	9.05	9.03
Moment of Inertia (≤ Ø38)	[kgcm ²]	--	13.1	13.0	12.9	12.8	12.7	12.7
Efficiency	[%]	*4	85	84	80	76	73	70
Torsional Rigidity	[Nm/arcmin]	--	38.5					
Maximum Torsional Backlash (Standard)	[Arc-min]	--	≤ 4					
Maximum Torsional Backlash (Zero)	[Arc-min]	--	≤ 0					
Noise Level	dB [A]	*5	≤ 80					
Ambient Temperature	[°C]	--	-25 ~ 100					
Permitted Housing Temperature	[°C]	--	100					
Protection Class	--	--	IP65					
Lubrication	--	--	Synthetic Oil					
Service Life	[Hours]	--	25,000					
Weight	[kg]	*6	25					

*1) Torque at no load applied to the input shaft at 2,000 rpm

*2) The maximum radial load the gearbox can accept

*3) The maximum axial load the gearbox can accept

*4) The efficiency at the nominal output torque rating

*5) Measured with no load applied to the input shaft at 2,000 rpm

*6) Weight may vary slightly between models

EJP SERIES Right-angle Worm

EJP Dimensions – Hollow Output Shaft

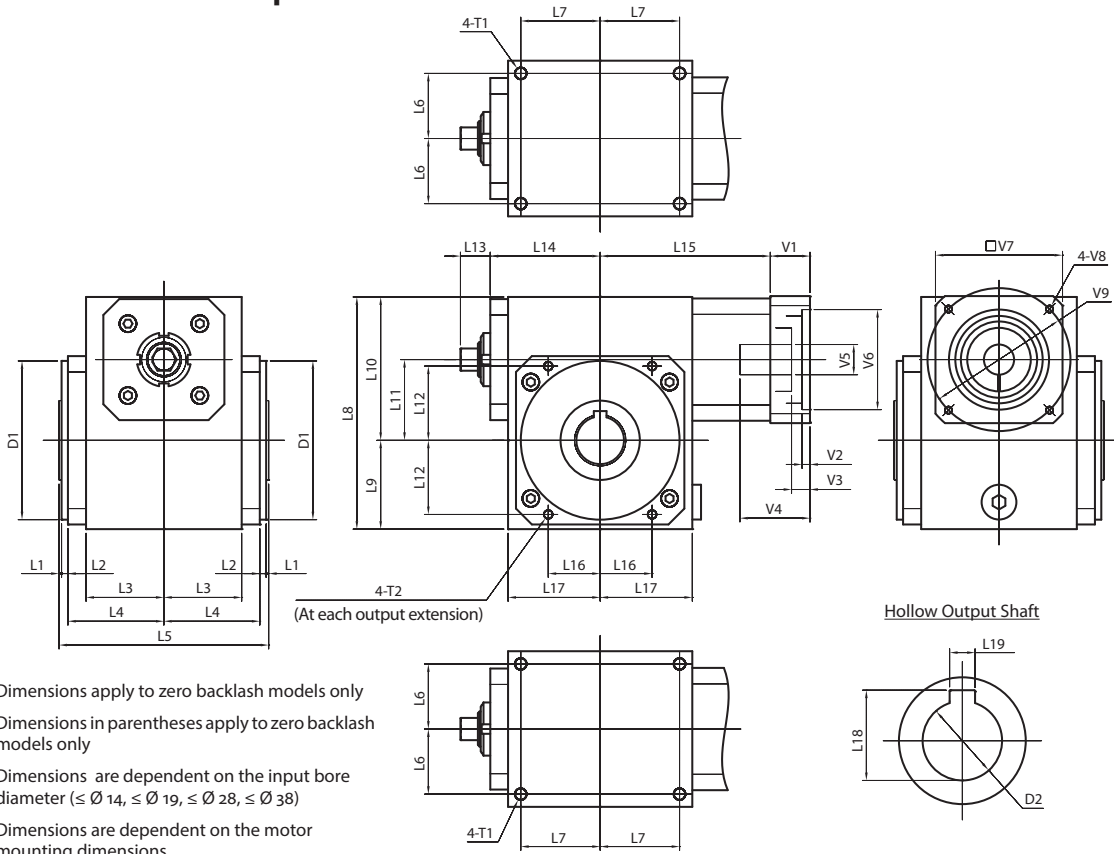

- *1) Dimensions apply to zero backlash models only
- *2) Dimensions in parentheses apply to zero backlash models only
- *3) Dimensions are dependent on the input bore diameter ($\leq \varnothing 14$, $\leq \varnothing 19$, $\leq \varnothing 28$, $\leq \varnothing 38$)
- *4) Dimensions are dependent on the motor mounting dimensions

Frame Size	Unit	Note	EJP-038	EJP-051	EJP-064	EJP-076	EJP-089
L1	[mm]	--	1	1	1	2	2
L2	[mm]	--	4	4	4	4	4
L3	[mm]	--	39	49	54	73.5	90
L4	[mm]	--	51	60.5	70	94	111.5
L5	[mm]	--	112	132	148	200	234
L6	[mm]	--	32	41	44	63	80
L7	[mm]	--	42	50	68.5	79	95
L8	[mm]	--	118	146.5	181	214	252
L9	[mm]	--	45	56	73	82	100
L10	[mm]	--	73	90.5	108	132	152
L11	[mm]	--	38.1	50.8	63.5	76.2	88.9
L12	[mm]	--	34.5	46.5	57.5	64.5	80.5
L13	[mm]	*1	---	22	22	32	35
L14	[mm]	*2	63	69.5 (71)	94 (96)	110 (111)	125.5 (131)
L15	[mm]	*3	96.5 - 106.5	105 - 115	130.5 - 142.5	151 - 163	165 - 177
L16	[mm]	--	18.5	32.5	40	45.5	46.5
L17	[mm]	--	50.5	58	79	89.5	105
L18	[mm]	--	28.5	33.5	38.5	49.0	64.5
L19	[mm]	--	8	8	10	14	18
D1 (h8)	[mm]	--	$\varnothing 64$	$\varnothing 100$	$\varnothing 120$	$\varnothing 134$	$\varnothing 145$
D2 (H7)	[mm]	--	$\varnothing 25$	$\varnothing 30$	$\varnothing 35$	$\varnothing 45$	$\varnothing 60$
T1	[mm]	--	4xM8x12	4xM8x12	4xM8x12	4xM10x15	4xM10x15
T2	[mm]	--	4xM6x9	4xM6x9	4xM8x12	4xM10x15	4xM10x15
V1 ~ V9	[mm]	*4	Motor attachment dimensions are made to fit your servo motor.				

EJP Dimensions – Solid Output Shaft

- *1) Dimensions apply to zero backlash models only
- *2) Dimensions in parentheses apply to zero backlash models only

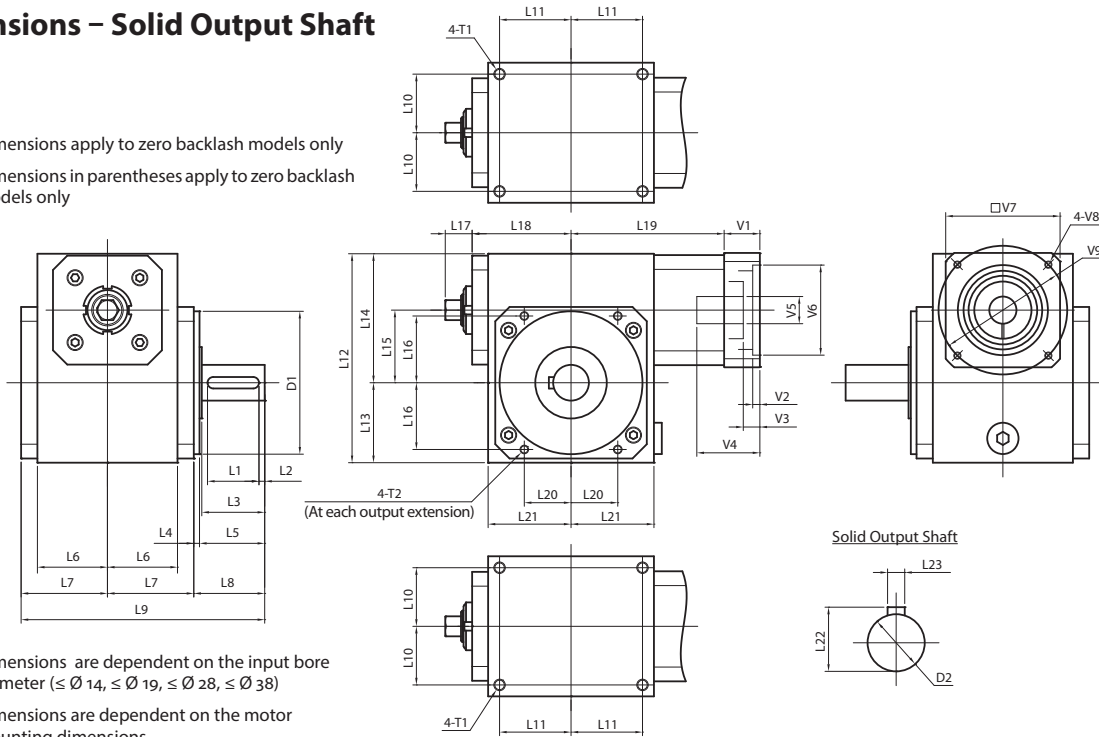

- *3) Dimensions are dependent on the input bore diameter ($\leq \varnothing 14$, $\leq \varnothing 19$, $\leq \varnothing 28$, $\leq \varnothing 38$)
- *4) Dimensions are dependent on the motor mounting dimensions

Frame Size	Unit	Note	EJP-038	EJP-051	EJP-064	EJP-076	EJP-089
L1	[mm]	--	22	36	40	50	63
L2	[mm]	--	90	4	4	5	5
L3	[mm]	--	30	44	50	67	83
L4	[mm]	--	4	4	4	4	4
L5	[mm]	--	31	45.5	51	67	84.5
L6	[mm]	--	39	49	54	73.5	90
L7	[mm]	--	51	60.5	70	94	111
L8	[mm]	--	35	49.5	55	71	88.5
L9	[mm]	--	137	170.5	194	259	311.5
L10	[mm]	--	32	41	44	63	80
L11	[mm]	--	42	50	68.5	79	95
L12	[mm]	--	118	146.5	181	214	252
L13	[mm]	--	45	56	73	82	100
L14	[mm]	--	73	90.5	108	132	152
L15	[mm]	--	38.1	50.8	63.5	76.2	88.9
L16	[mm]	--	34.5	46.5	57.5	64.5	80.5
L17	[mm]	*1	---	22	22	32	35
L18	[mm]	*2	63	69.5 (71)	94 (96)	110 (111)	125.5 (131)
L19	[mm]	*3	96.5 - 106.5	105 - 115	130.5 - 142.5	151 - 163	165 - 177
L20	[mm]	--	18.5	32.5	40	45.5	46.5
L21	[mm]	--	50.5	58	79	89.5	105
L22	[mm]	--	22.5	28	33	38	48.5
L23	[mm]	--	6	8	8	10	14
D1 (h8)	[mm]	--	ø64	ø100	ø120	ø134	ø145
D2 (k6)	[mm]	--	ø20	ø25	ø30	ø35	ø45
T1	[mm]	--	4xM8x12	4xM8x12	4xM8x12	4xM10x15	4xM10x15
T2	[mm]	--	4xM6x9	4xM6x9	4xM8x12	4xM10x15	4xM10x15
V1 ~ V9	[mm]	*4	Motor attachment dimensions are made to fit your servo motor.				

EJP SERIES Right-angle Worm

EJP Dimensions – Flange Output

- *1) Dimensions apply to zero backlash models only
- *2) Dimensions in parentheses apply to zero backlash models only
- *3) Dimensions are dependent on the input bore diameter ($\leq \varnothing 14$, $\leq \varnothing 19$, $\leq \varnothing 28$, $\leq \varnothing 38$)

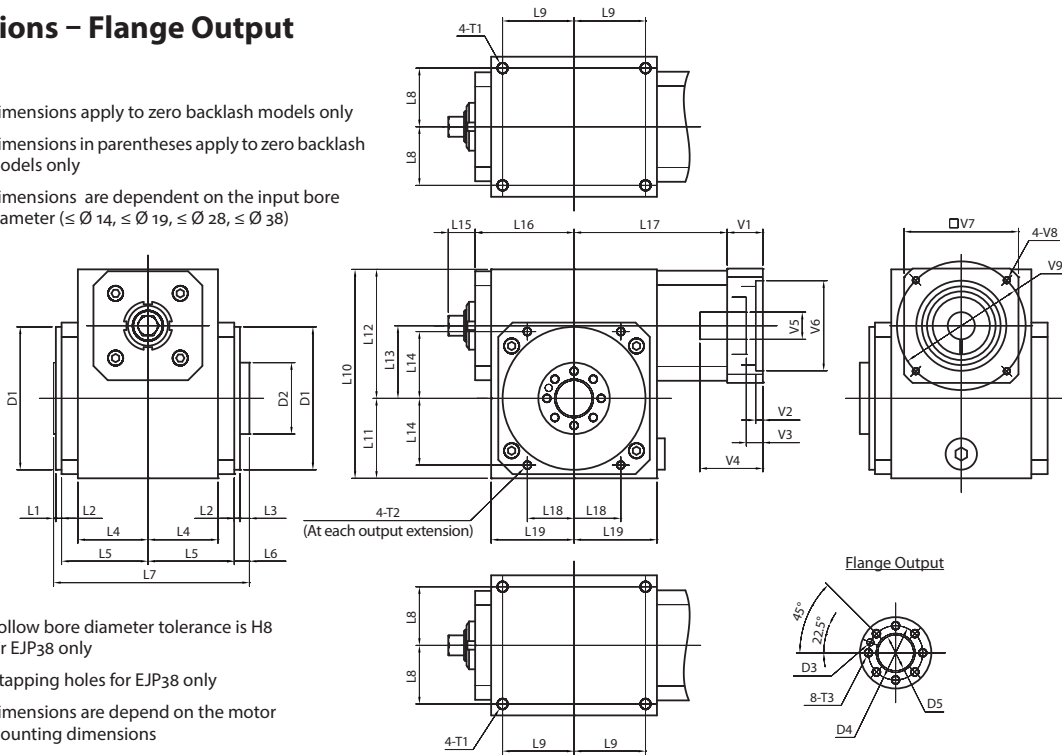

- *4) Hollow bore diameter tolerance is H8 for EJP38 only
- *5) 4 tapping holes for EJP38 only
- *6) Dimensions are depend on the motor mounting dimensions

Frame Size	Unit	Note	EJP-038	EJP-051	EJP-064	EJP-076	EJP-089
L1	[mm]	--	1	1.5	1.5	2	2
L2	[mm]	--	4	4	4	4	4
L3	[mm]	--	6	6.5	6	7	7
L4	[mm]	--	39	49	54	73.5	90
L5	[mm]	--	51	60.5	70	94	111
L6	[mm]	--	10	10.5	10	11	11
L7	[mm]	--	117	137	153	205	239
L8	[mm]	--	32	41	44	63	80
L9	[mm]	--	42	50	68.5	79	95
L10	[mm]	--	118	146.5	181	214	252
L11	[mm]	--	45	56	73	82	100
L12	[mm]	--	73	90.5	108	132	152
L13	[mm]	--	38.1	50.8	63.5	76.2	88.9
L14	[mm]	--	34.5	46.5	57.5	64.5	80.5
L15	[mm]	*1	--	22	22	32	35
L16	[mm]	*2	63	69.5 (71)	94 (96)	110 (111)	125.5 (131)
L17	[mm]	*3	96.5 - 106.5	105 - 115	130.5 - 142.5	151 - 163	165 - 177
L18	[mm]	--	18.5	32.5	40	45.5	46.5
L19	[mm]	--	50.5	58	79	89.5	105
D1 (h8)	[mm]	--	$\varnothing 64$	$\varnothing 100$	$\varnothing 120$	$\varnothing 134$	$\varnothing 145$
D2 (h11)	[mm]	--	$\varnothing 40$	$\varnothing 50$	$\varnothing 65$	$\varnothing 80$	$\varnothing 90$
D3 (H9)	[mm]	--	$\varnothing 5 \times 10$	$\varnothing 5 \times 10$	$\varnothing 6 \times 10$	$\varnothing 8 \times 10$	$\varnothing 8 \times 10$
D4	[mm]	--	$\varnothing 28$	$\varnothing 38$	$\varnothing 50$	$\varnothing 60$	$\varnothing 70$
D5 (H7)	[mm]	*4	$\varnothing 16$	$\varnothing 25$	$\varnothing 30$	$\varnothing 35$	$\varnothing 45$
T1	[mm]	--	4xM8x12	4xM8x12	4xM8x12	4xM10x15	4xM10x15
T2	[mm]	--	4xM6x9	4xM6x9	4xM8x12	4xM10x15	4xM10x15
T3	[mm]	*5	4xM6x12	8xM6x12	8xM8x16	8xM8x16	8xM10x20
V1 ~ V9	[mm]	*6	Motor attachment dimensions are made to fit your servo motor.				

EJP Dimensions – Hollow Output with Shrink Disk

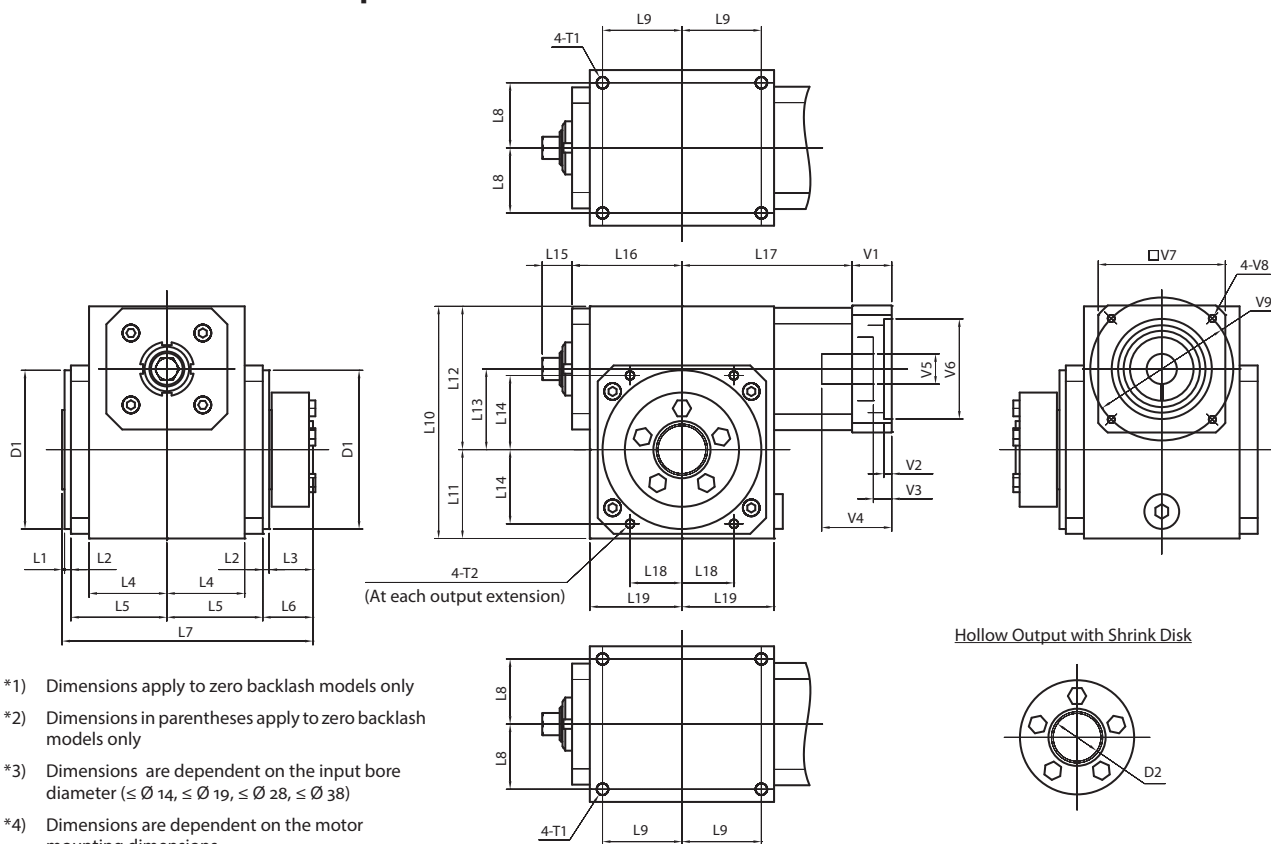

Hollow Output with Shrink Disk

- *1) Dimensions apply to zero backlash models only
- *2) Dimensions in parentheses apply to zero backlash models only
- *3) Dimensions are dependent on the input bore diameter ($\leq \varnothing 14$, $\leq \varnothing 19$, $\leq \varnothing 28$, $\leq \varnothing 38$)
- *4) Dimensions are dependent on the motor mounting dimensions

Frame Size	Unit	Note	EJP-038	EJP-051	EJP-064	EJP-076	EJP-089
L1	[mm]	--	1	1.5	1.5	2	2
L2	[mm]	--	4	4	4	4	4
L3	[mm]	--	25	27.5	36	37	38.5
L4	[mm]	--	39	49	54	73.5	90
L5	[mm]	--	51	60.5	70	94	111
L6	[mm]	--	29	31.5	40	41	42.5
L7	[mm]	--	136	158	183	235	271
L8	[mm]	--	32	41	44	63	80
L9	[mm]	--	42	50	68.5	79	95
L10	[mm]	--	118	146.5	181	214	252
L11	[mm]	--	45	56	73	82	100
L12	[mm]	--	73	90.5	108	132	152
L13	[mm]	--	38.1	50.8	63.5	76.2	88.9
L14	[mm]	--	34.5	46.5	57.5	64.5	80.5
L15	[mm]	*1	---	22	22	32	35
L16	[mm]	*2	63	69.5 (71)	94 (96)	110 (111)	125.5 (131)
L17	[mm]	*3	96.5 - 106.5	105 - 115	130.5 - 142.5	151 - 163	165 - 177
L18	[mm]	--	18.5	32.5	40	45.5	46.5
L19	[mm]	--	50.5	58	79	89.5	105
D1 (h8)	[mm]	--	$\varnothing 64$	$\varnothing 100$	$\varnothing 120$	$\varnothing 134$	$\varnothing 145$
D2 (H6)	[mm]	--	$\varnothing 25$	$\varnothing 30$	$\varnothing 35$	$\varnothing 45$	$\varnothing 60$
T1	[mm]	--	4xM8x12	4xM8x12	4xM8x12	4xM10x15	4xM10x15
T2	[mm]	--	4xM6x9	4xM6x9	4xM8x12	4xM10x15	4xM10x15
V1 ~ V9	[mm]	*4	Motor attachment dimensions are made to fit your servo motor.				