

## EJM 006 1-Stage Specifications

Frame Size	006							
Ratio	Unit	Note	5	7.5	10	15	20	
Nominal Output Torque	[Nm]	--	133	144	145	165	168	
Maximum Acceleration Torque	[Nm]	--	172	183	154	186	207	
Emergency Stop Torque	[Nm]	--	266	288	290	330	336	
No Load Running Torque	[Nm]	*1						2.72
Nominal Input Speed	[rpm]	--						2,000
Maximum Continuous Input Speed	[rpm]	--						3,000
Maximum Cyclic Input Speed	[rpm]	--						4,000
Maximum Radial Load	[N]	*2						4,890
Maximum Axial Load	[N]	*3						3,550
Moment of Inertia	[kgcm <sup>2</sup> ]	--	2.61	2.02	1.81	1.66	1.61	
Efficiency	[%]	*4	92	91	89	87	83	
Torsional Rigidity	[Nm/arcmin]	--						5.6
Maximum Torsional Backlash	[Arc-min]	--						≤ 20
Noise Level	dB [A]	*5						≤ 80
Ambient Temperature	[°C]	--						-25 ~ 93
Permitted Housing Temperature	[°C]	--						100
Protection Class	--	--						IP55
Lubrication	--	--						Synthetic Oil
Service Life	[Hours]	--						25,000
Weight	[kg]	*6						10

- \*1) Torque at no load applied to the input shaft at 2,000 rpm
- \*2) The maximum radial load the gearbox can accept
- \*3) The maximum axial load the gearbox can accept
- \*4) The efficiency at the nominal output torque rating
- \*5) Measured with no load applied to the input shaft at 2,000 rpm
- \*6) Weight may vary slightly between models

## EJM 006 1-Stage Specifications

Frame Size	006						
Ratio	Unit	Note	25	30	40	50	60
Nominal Output Torque	[Nm]	--	183	175	158	150	142
Maximum Acceleration Torque	[Nm]	--	223	212	191	181	170
Emergency Stop Torque	[Nm]	--	366	350	316	300	284
No Load Running Torque	[Nm]	*1	2.72				
Nominal Input Speed	[rpm]	--	2,000				
Maximum Continuous Input Speed	[rpm]	--	3,000				
Maximum Cyclic Input Speed	[rpm]	--	4,000				
Maximum Radial Load	[N]	*2	4,890				
Maximum Axial Load	[N]	*3	3,550				
Moment of Inertia	[kgcm <sup>2</sup> ]	--	1.58	1.57	1.56	1.55	1.55
Efficiency	[%]	*4	80	78	72	66	62
Torsional Rigidity	[Nm/arcmin]	--	5.6				
Maximum Torsional Backlash	[Arc-min]	--	≤ 20				
Noise Level	dB [A]	*5	≤ 80				
Ambient Temperature	[°C]	--	-25 ~ 93				
Permitted Housing Temperature	[°C]	--	100				
Protection Class	--	--	IP55				
Lubrication	--	--	Synthetic Oil				
Service Life	[Hours]	--	25,000				
Weight	[kg]	*6	10				

\*1) Torque at no load applied to the input shaft at 2,000 rpm

\*2) The maximum radial load the gearbox can accept

\*3) The maximum axial load the gearbox can accept

\*4) The efficiency at the nominal output torque rating

\*5) Measured with no load applied to the input shaft at 2,000 rpm

\*6) Weight may vary slightly between models

# EJM SERIES Right-angle Worm

## EJM Dimensions – Hollow Output Shaft

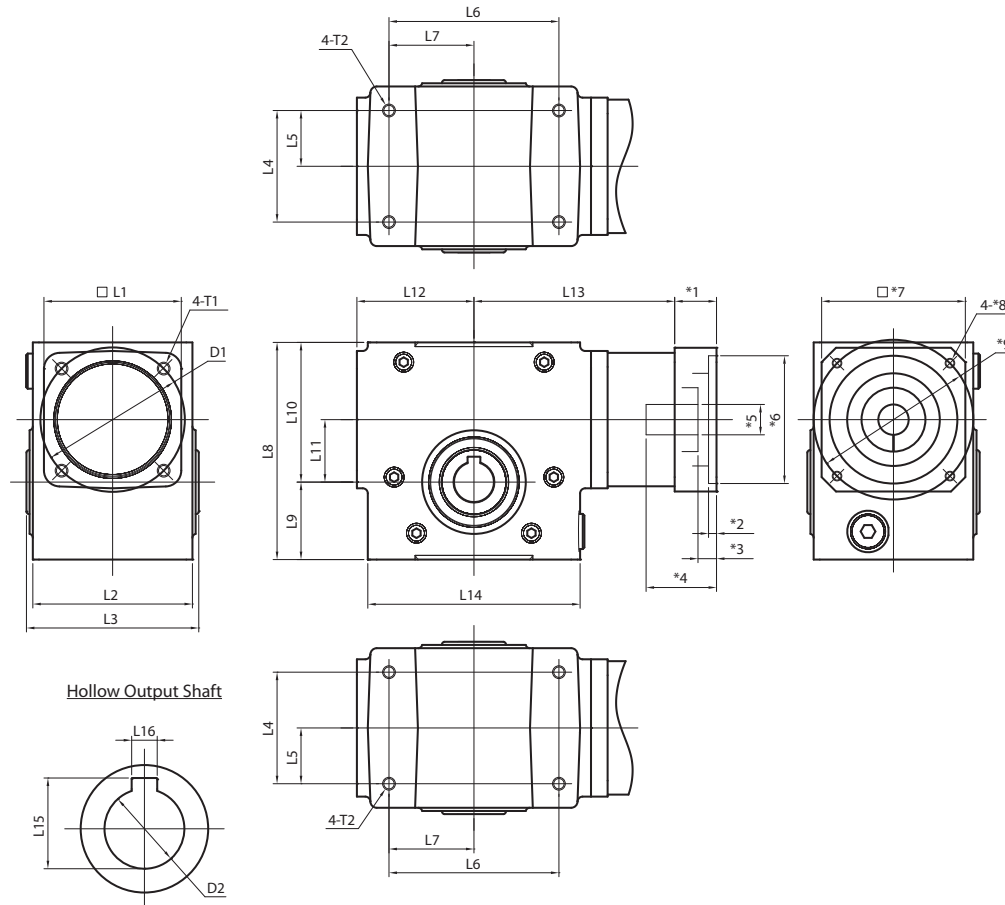

Frame Size	Unit	Note	EJM-002	EJM-003	EJM-005	EJM-006	EJM-009	EJM-011
L1	[mm]	--	60	86	86	86	116	116
L2	[mm]	--	70	100	100	100	130	130
L3	[mm]	--	98	108	107	108	138	169
L4	[mm]	--	51	70	73	73	102	102
L5	[mm]	--	25	35	37	37	51	51
L6	[mm]	--	83	106	127	127	178	191
L7	[mm]	--	41	53	64	64	89	95
L8	[mm]	--	118.5	136	162	176	225.5	250
L9	[mm]	--	43.5	48.5	58	63.5	82.5	86
L10	[mm]	--	75	87.5	104	112.5	143	164
L11	[mm]	--	33.8	39.1	50.0	60.5	76.2	89.9
L12	[mm]	--	67	73	84	95	117	130
L13	[mm]	--	126	126	136	147	184	197
L14	[mm]	--	110	133	152	178	229	241
L15	[mm]	--	23	28.5	38.5	38.5	59.5	80
L16	[mm]	--	6	8	10	10	16	20
D1	[mm]	--	ø64	ø90.5	ø90.5	ø90.5	ø127	ø127
D2 (H7)	[mm]	--	ø20	ø25	ø35	ø35	ø55	ø75
T1	[mm]	--	M8x12	M8x12	M8x12	M8x12	M8x12	M8x12
T2	[mm]	--	M8x12	M8x12	M10x15	M10x15	M12x18	M16x24
*1 ~	[mm]	*9	Motor attachment dimensions are made to fit your servo motor.					

## EJM Dimensions – Solid Output Shaft

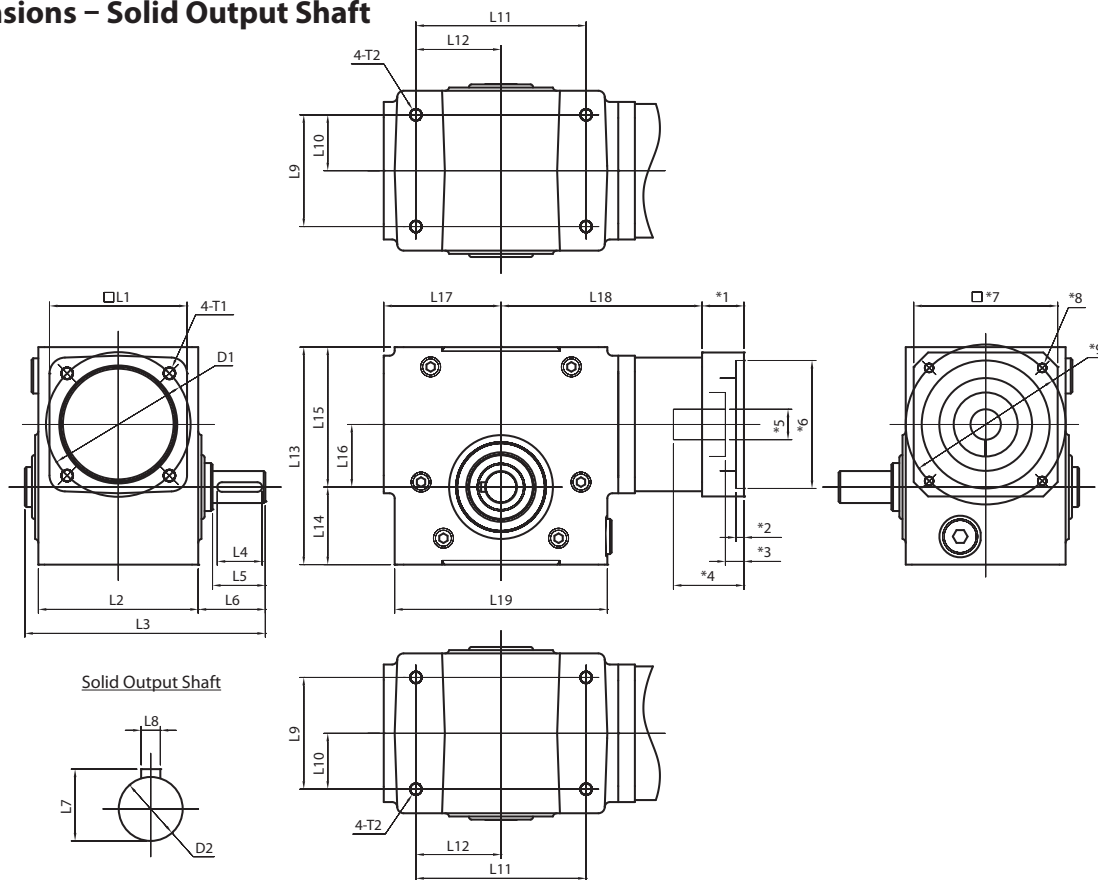

Solid Output Shaft

Frame Size	Unit	Note	EJM-002	EJM-003	EJM-005	EJM-006	EJM-009	EJM-011
L1	[mm]	--	60	86	86	86	116	116
L2	[mm]	--	70	100	100	100	130	130
L3	[mm]	--	140.5	150.5	156	173	204	261
L4	[mm]	--	28	28	36	50	50	70
L5	[mm]	--	33	33	39	55	54	79
L6	[mm]	--	52	42	48	64	64	105
L7	[mm]	--	22.5	22.5	28	33	38	45
L8	[mm]	--	6	6	8	8	10	12
L9	[mm]	--	51	70	73	73	102	102
L10	[mm]	--	25.5	35	36.5	36.5	51	51
L11	[mm]	--	83	106	127	127	178	191
L12	[mm]	--	41.5	53	63.5	63.5	89	95.5
L13	[mm]	--	118.5	136	162	176	225.5	250
L14	[mm]	--	43.5	48.5	58	63.5	82.5	86
L15	[mm]	--	75	87.5	104	112.5	143	164
L16	[mm]	--	33.8	39.1	50.0	60.5	76.2	89.9
L17	[mm]	--	67	73.5	84	95	117	130
L18	[mm]	--	125.5	125.5	136.5	147.5	184	197
L19	[mm]	--	110	133	152.5	178	228.5	241.5
D1	[mm]	--	ø64	ø90.5	ø90.5	ø90.5	ø127	ø127
D2 (h6)	[mm]	--	ø20	ø20	ø25	ø30	ø35	ø42
T1	[mm]	--	M8 x12	M8 x12	M8 x12	M8 x12	M8 x12	M8 x12
T2	[mm]	--	M8 x12	M8 x12	M10 x15	M10 x15	M12 x18	M16 x24
*1 ~	[mm]	*9	Motor attachment dimensions are made to fit your servo motor.					