

Installation Instructions

Right-angle Precision Worm Products – EJL Series

Servo Coupling Mounting

Install the coupling onto the gearbox input shaft. Position it axially ensuring that the clamping length is completely engaged, leaving a small gap (h) between the coupling and the gearbox flange face.

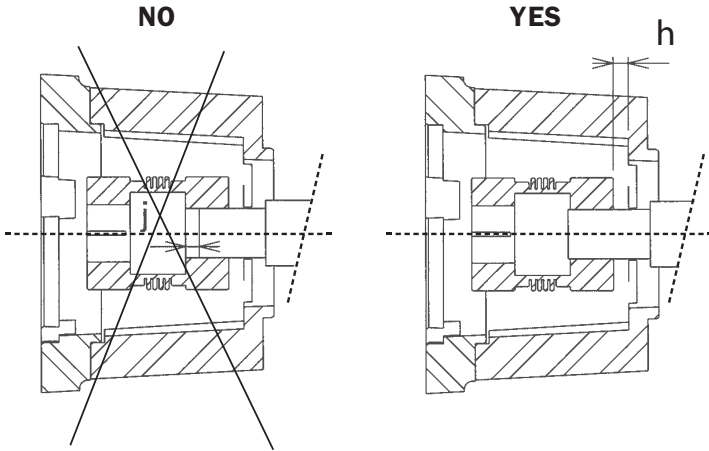

Measure the length (L) between the motor flange face and the coupling front face:

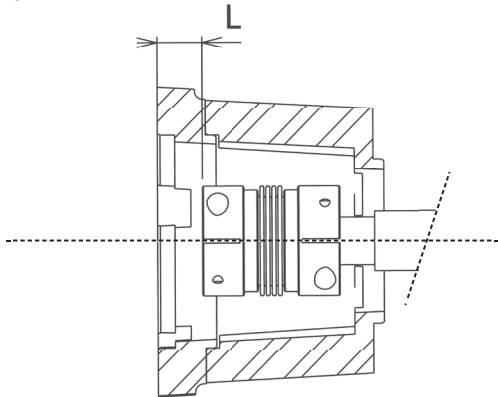

Dismount the coupling from the gearbox and engage it on the motor shaft, leaving (L) dimension intact:

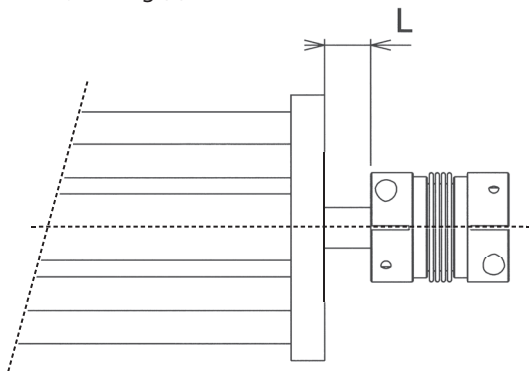

Prior to mounting, and to ease dismounting, make sure the coupling hub is slightly oiled.

Tighten the coupling screw on motor side at the required torque as per following chart:

Motor Installation Bolt Size	M4	M5	M6	M8	M10	M12	M16
Tightening Torque (Nm)	4.5	8	15	40	85	120	200

Engage the motor and coupling assembly on the gearbox. Hold the motor flange and gearbox flange together using the four motor flange screws. Tighten the coupling screw on the gearbox side through the radial bore located on the gearbox flange to the required torque, as per the previous chart.

Mounting of shrink disc for smooth hollow shaft configuration

Shrink disc is delivered ready for use. Do not dismount it.

Carefully remove any grease from the gearbox output bore and from the machine shaft.

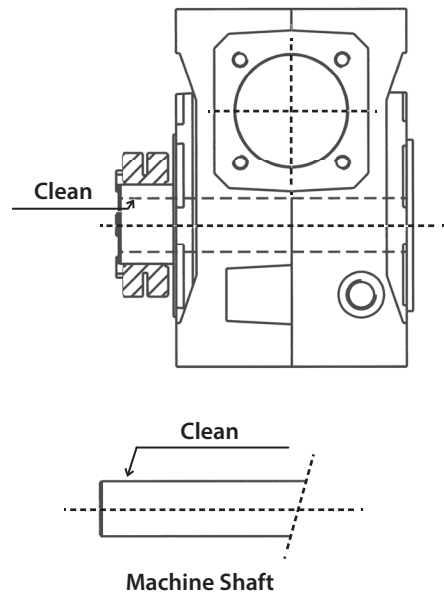

Do not tighten the shrink disc screws before having engaged the gearbox on the machine shaft.

Nidec

NIDEC DRIVE TECHNOLOGY CORPORATION

175 Wall Street, Glendale Heights, IL 60139, USA • P: (800) 842-1479 • info@nidec-dtc.com • www.nidec-dtc.com

Engage the gearbox on the shaft. Hold the gearbox on the machine. Tighten the shrink disc screws, in the same order as shown in below sketch, increasing the torque very progressively.

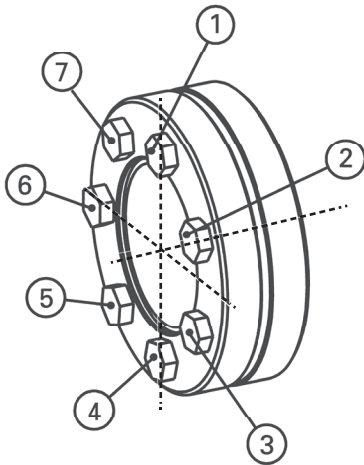

Tighten to the torque value shown in the chart below. **It is normal that each screw must be tightened several times until the torque is obtained.**

Shrink disc screw \varnothing	Tightening torque
M6	13 Nm
M8	30 Nm
M10	60 Nm
M12	160 Nm

Warning: before use, the breather plug (delivered with gearbox) must be mounted within the upper cavity of the gearbox, based on the mounting orientation, as shown below. This will replace the existing oil plug.

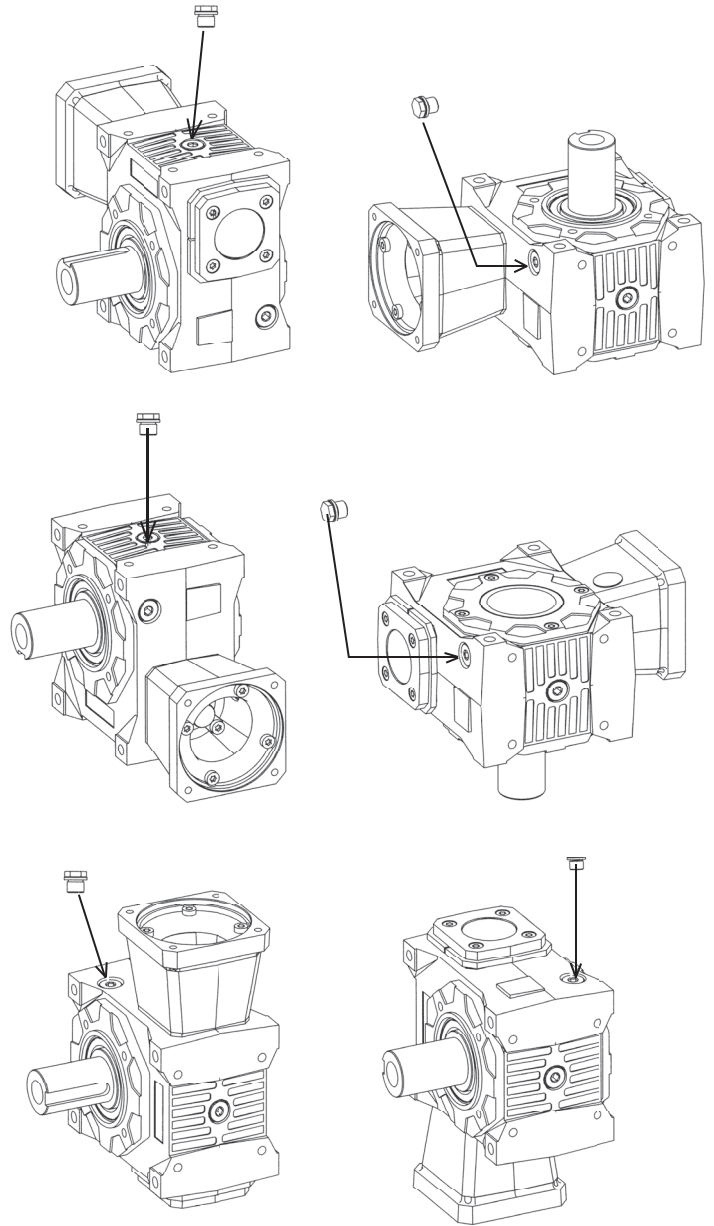

Lubrication

The EJL series products are delivered filled with synthetic lubricant **MOBIL GLYGOYLE 30**. The main specifications of this high performance lubricant are:

- Range of temperature: from -30°C to $+130^{\circ}\text{C}$
- Reduction of friction up to 20%
- Exceptional anti-wear properties
- Lubricant life up to 4 times higher than classical lubricants.

For this reason, there is no need to do regular oil changes. Never mix this oil with any other type of lubricant.

Run-in Period

During the run-in period (up to 48 hours, depending on applied load), the gearbox will see higher than average temperatures. This is normal.

The gearbox housing temperature will steadily decrease and stabilize over the course of the run-in period.

Nidec

NIDEC DRIVE TECHNOLOGY CORPORATION

175 Wall Street, Glendale Heights, IL 60139, USA • P: (800) 842-1479 • info@nidec-dtc.com • www.nidec-dtc.com