

EJL 090 1-Stage Specifications

Frame Size	090							
Ratio	Unit	Note	5.2	7.25	10.25	14.5	19.5	
Nominal Output Torque	[Nm]	*1	271	306	314	314	367	
Maximum Acceleration Torque	[Nm]	*1	460	490	528	504	584	
Emergency Stop Torque	[Nm]	--	1,543	1,543	1,543	1,543	1,543	
No Load Running Torque	[Nm]	*2	2.97	2.62	2.33	1.99	1.76	
Nominal Input Speed	[rpm]	*1	3,000					
Maximum Continuous Input Speed	[rpm]	*1	4,000					
Maximum Cyclic Input Speed	[rpm]	--	6,000					
Maximum Radial Load	[N]	*3	15,800					
Maximum Axial Load	[N]	*4	13,000					
Moment of Inertia	[kgcm ²]	--	8.5	6	3.8	3.2	2.5	
Efficiency	[%]	*5	94	94	92	88	87	
Torsional Rigidity	[Nm/arcmin]	--	75					
Maximum Torsional Backlash (Standard)	[Arc-min]	--	≤ 10					
Maximum Torsional Backlash (Low)	[Arc-min]	--	≤ 5					
Maximum Torsional Backlash (Precision)	[Arc-min]	--	≤ 1					
Noise Level	dB [A]	*6	75					
Ambient Temperature	[°C]	--	-30 to +40					
Permitted Housing Temperature	[°C]	--	+80					
Protection Class	--	--	IP65					
Lubrication	--	--	Synthetic Oil					
Service Life	[Hours]	--	25,000					
Weight	[kg]	*7	33.8					

*1) Higher output torque is available at reduced speed. Contact us if you need to operate outside of these parameters

*2) Input torque with no load applied to the output shaft at 2,000 rpm

*3) The maximum radial load the gearbox can accept

*4) The maximum axial load the gearbox can accept

*5) The efficiency at the nominal output torque and input speed rating

*6) Measured with no load applied to the output shaft at 3,000 rpm and 1 meter distance

*7) Weight may vary slightly between models

EJL 090 1-Stage Specifications

Frame Size	090					
Ratio	Unit	Note	30	45	60	90
Nominal Output Torque	[Nm]	*1	362	385	364	332
Maximum Acceleration Torque	[Nm]	*1	572	599	559	505
Emergency Stop Torque	[Nm]	--	1,543	1,255	1,230	1,114
No Load Running Torque	[Nm]	*2	1.79	1.43	1.65	1.70
Nominal Input Speed	[rpm]	*1	3,000			
Maximum Continuous Input Speed	[rpm]	*1	4,000			
Maximum Cyclic Input Speed	[rpm]	--	6,000			
Maximum Radial Load	[N]	*3	15,800			
Maximum Axial Load	[N]	*4	13,000			
Moment of Inertia	[kgcm ²]	--	2.6	1.9	1.7	1
Efficiency	[%]	*5	80	76	72	64
Torsional Rigidity	[Nm/arcmin]	--	75			
Maximum Torsional Backlash (Standard)	[Arc-min]	--	≤ 10			
Maximum Torsional Backlash (Low)	[Arc-min]	--	≤ 5			
Maximum Torsional Backlash (Precision)	[Arc-min]	--	≤ 1			
Noise Level	dB [A]	*6	75			
Ambient Temperature	[°C]	--	-30 to +40			
Permitted Housing Temperature	[°C]	--	+80			
Protection Class	--	--	IP65			
Lubrication	--	--	Synthetic Oil			
Service Life	[Hours]	--	25,000			
Weight	[kg]	*7	33.8			

*1) Higher output torque is available at reduced speed. Contact us if you need to operate outside of these parameters

*2) Input torque with no load applied to the output shaft at 2,000 rpm

*3) The maximum radial load the gearbox can accept

*4) The maximum axial load the gearbox can accept

*5) The efficiency at the nominal output torque and input speed rating

*6) Measured with no load applied to the output shaft at 3,000 rpm and 1 meter distance

*7) Weight may vary slightly between models

EJL SERIES Right-angle Worm

EJL Dimensions – Hollow Output Shaft with Keyway

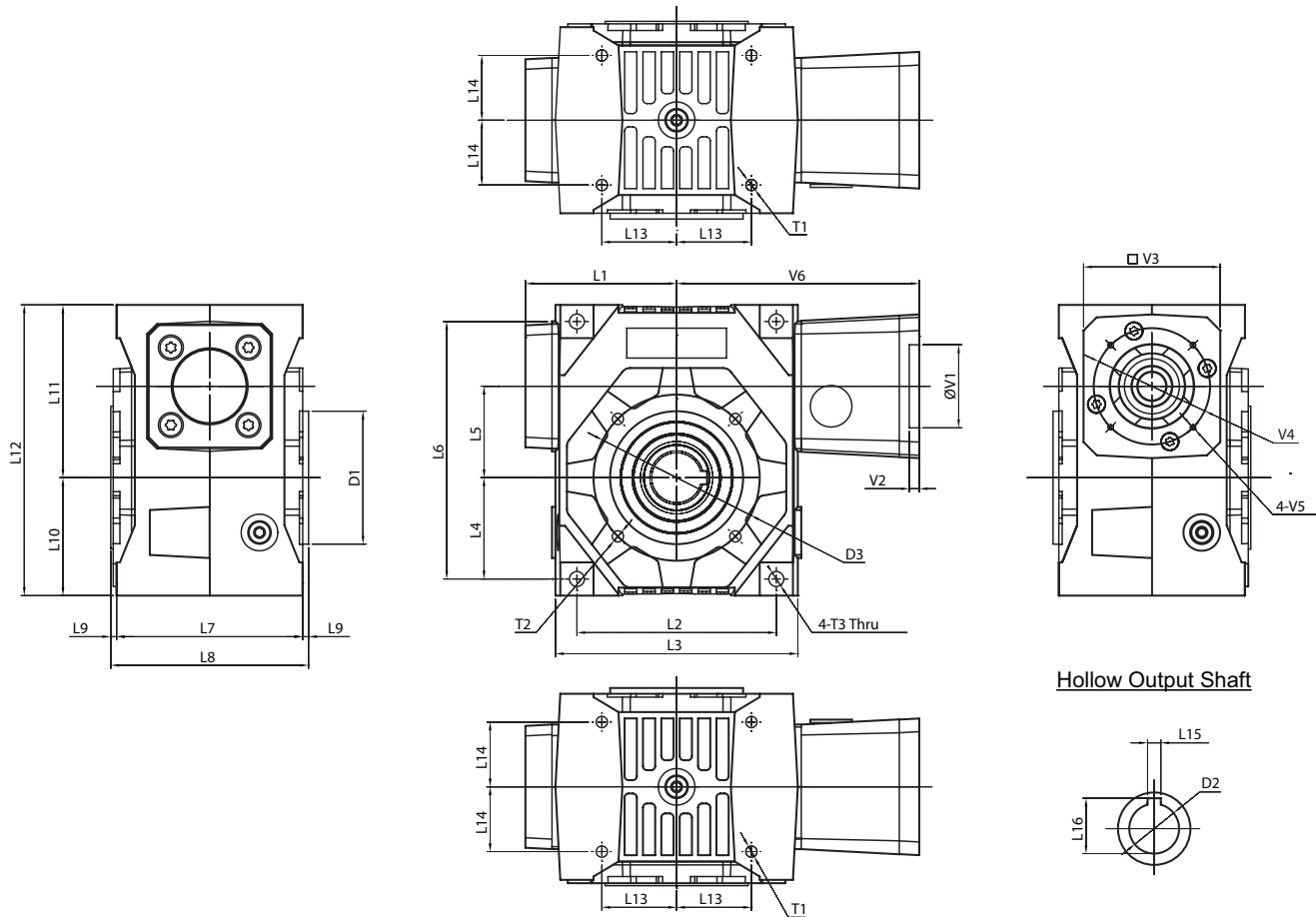

Hollow Output Shaft

Frame Size	Unit	EJL25	EJL35	EJL45	EJL55
L1	[mm]	49	70	83.5	91
L2	[mm]	66	86	108	120
L3	[mm]	82	107	132	146
L4	[mm]	33	44.5	53	61
L5	[mm]	25	35	45	55
L6	[mm]	84	110	135	155
L7	[mm]	64	86	100	112
L8	[mm]	70	92	106	119
L9	[mm]	3	3	3	3.5
L10	[mm]	39	52.5	62	71
L11	[mm]	57	73.5	91	104
L12	[mm]	96	126	153	175
L13	[mm]	24.75	31	40.5	45
L14	[mm]	22	28	34	39
L15	[mm]	5	5	8	8
L16	[mm]	16.3	18.3	28.3	33.3
D1 (j7)	[mm]	55	50	70	80
D2 (H7)	[mm]	14	16	25	30
D3	[mm]	65	65	85	100
T1	[mm]	4-M5	4-M6	4-M8	4-M8
T2	[mm]	4-M5	4-M6	4-M8	4-M8
T3	[mm]	6.2	7	9	9
V1 ~ V6	Motor attachment dimensions are made to fit your servo motor.				

EJL Dimensions – Hollow Output Shaft with Keyway

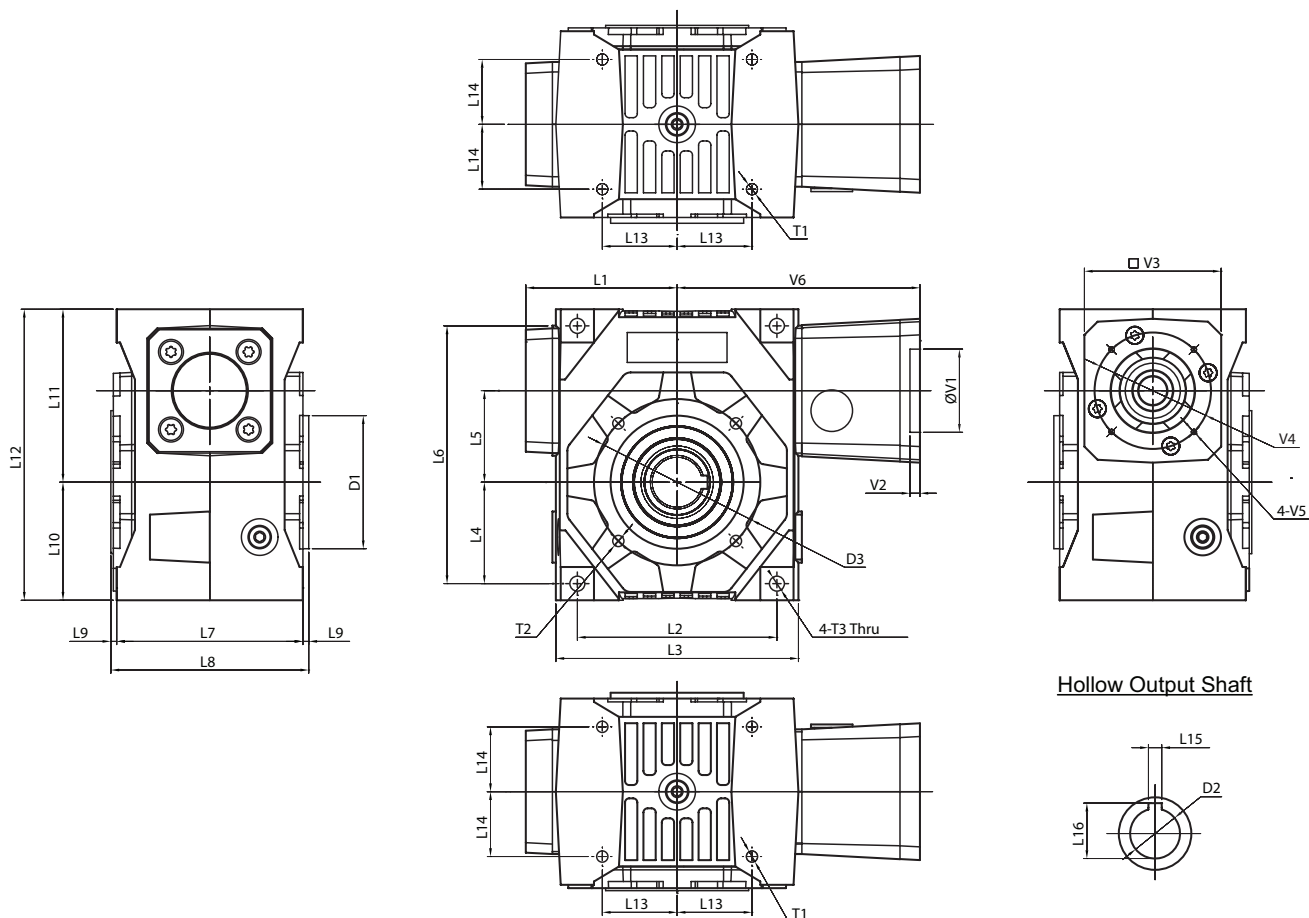

Frame Size	Unit	EJL63	EJL75	EJL90	EJL110
L1	[mm]	101	124	136.5	152
L2	[mm]	134	172	186	220
L3	[mm]	165	204	225	260
L4	[mm]	66	82	91	108
L5	[mm]	63	75	90	110
L6	[mm]	173	208	234	276
L7	[mm]	127	148	170	182
L8	[mm]	134	156	178	192
L9	[mm]	3.5	4	4	5
L10	[mm]	78	94	106	123
L11	[mm]	119	138	158	183
L12	[mm]	197	232	264	306
L13	[mm]	49	68	70.5	87.5
L14	[mm]	45.5	55	65	70
L15	[mm]	10	12	14	18
L16	[mm]	38.3	43.3	53.8	64.4
D1 (j7)	[mm]	95	110	130	165
D2 (H7)	[mm]	35	40	50	60
D3	[mm]	115	130	165	200
T1	[mm]	4-M10	4-M10	4-M12	8-M12
T2	[mm]	4-M10	4-M10	4-M12	8-M12
T3	[mm]	11	11	13	13
V1 ~ V6	Motor attachment dimensions are made to fit your servo motor.				

EJL SERIES Right-angle Worm

EJL Dimensions – Shrink Disc Hollow Output Shaft

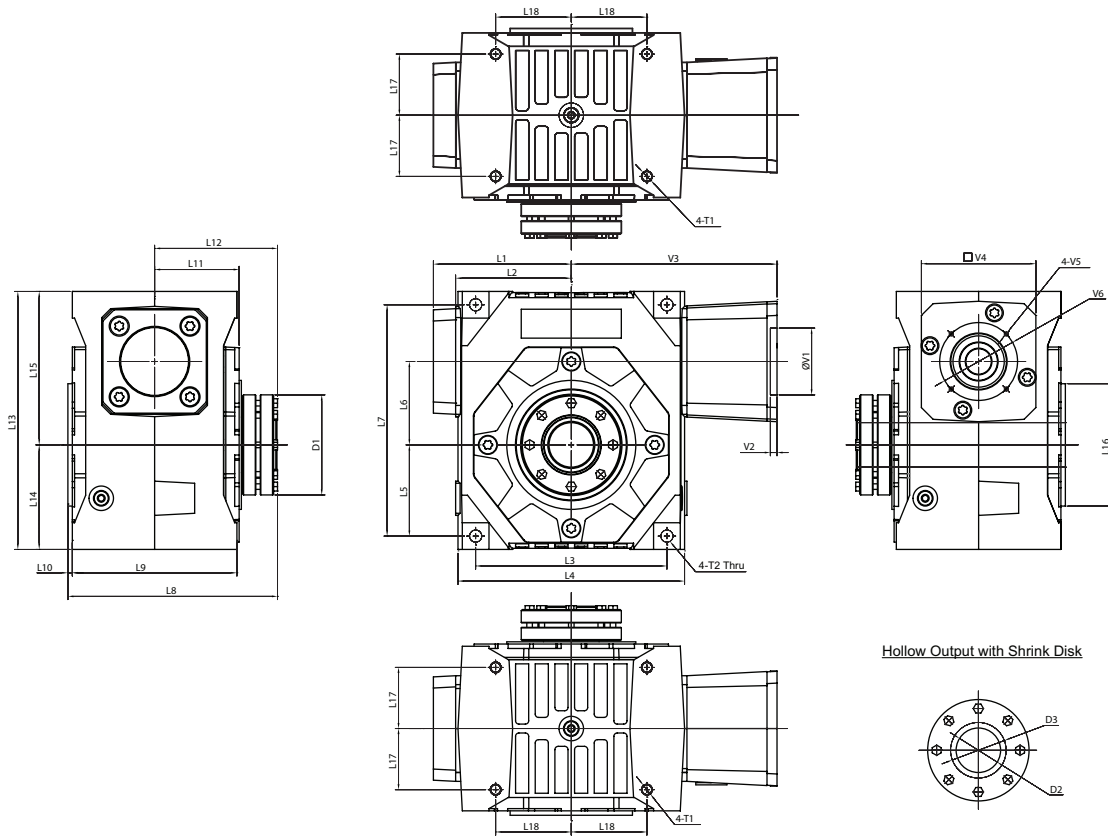

Frame Size	Unit	EJL35	EJL45	EJL55	EJL63	EJL75	EJL90	EJL110
L1	[mm]	70	83.5	91	101	124	136.5	152
L2	[mm]	55	67.5	75	84	104	114.5	132
L3	[mm]	86	108	120	134	172	186	220
L4	[mm]	107	132	146	165	204	225	260
L5	[mm]	44.5	53	61	66	82	91	108
L6	[mm]	35	45	55	63	75	90	110
L7	[mm]	110	135	155	173	208	234	276
L8	[mm]	117	132	150	165	188	213	229
L9	[mm]	86	100	112	127	148	170	182
L10	[mm]	3	3	3.5	3.5	4	4	5
L11	[mm]	45	52	58	65.5	76	88	94
L12	[mm]	70.5	79.5	90.5	98	110	124	133
L13	[mm]	126	153	175	197	232	264	306
L14	[mm]	52.5	62	71	78	94	106	123
L15	[mm]	73.5	91	104	119	138	158	183
L16	[mm]	50	70	80	95	110	130	165
L17	[mm]	28	34	39	45.5	55	65	70
L18	[mm]	31	40.5	45	49	68	70.5	87.5
D1	[mm]	50	60	72	80	90	115	145
D2 (H7)	[mm]	20	25	30	35	40	50	60
D3	[mm]	24	30	36	44	50	68	80
T1	[mm]	M6	M8	M8	M10	M10	M12	M12
T2	[mm]	7	9	9	11	11	13	13
V1 ~ V6		Motor attachment dimensions are made to fit your servo motor.						

EJL Dimensions – Shrink Disc Hollow Output Shaft

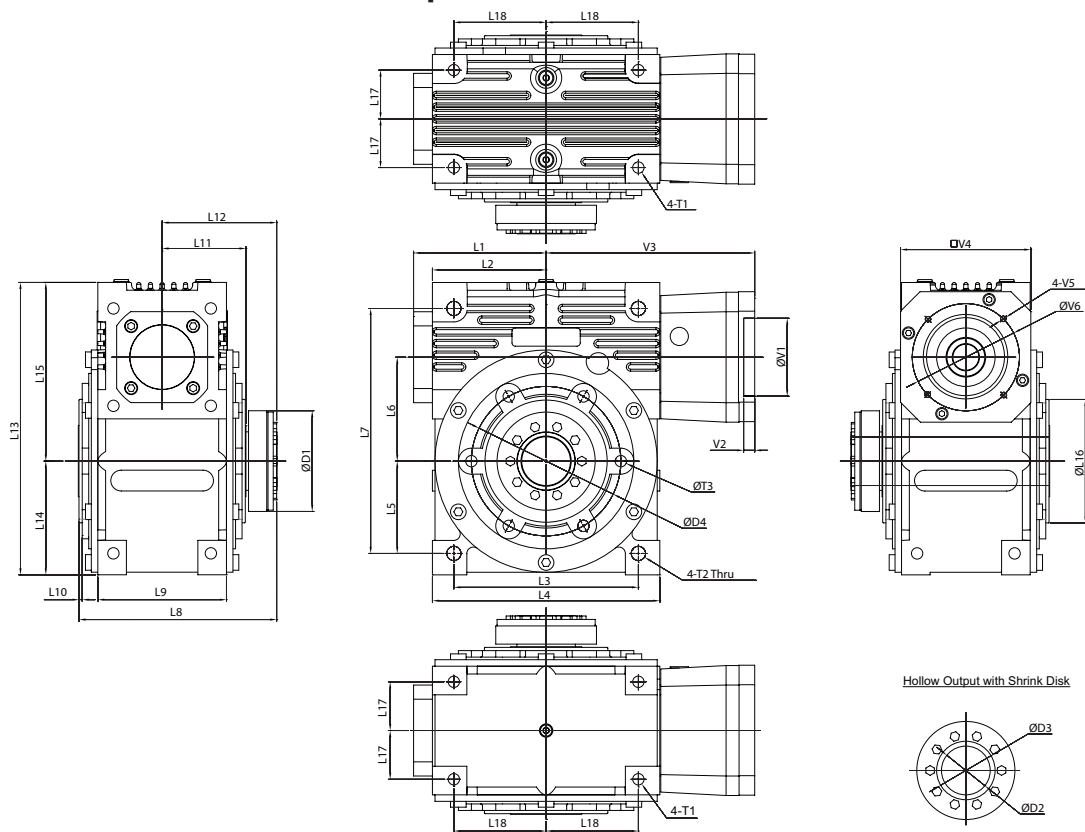

Frame Size	Unit	EJL125	EJL160	EJL200
L1	[mm]	163	204	251
L2	[mm]	135	175	216
L3	[mm]	214	284	342.5
L4	[mm]	270	346	432
L5	[mm]	107	142	171
L6	[mm]	125	160	200
L7	[mm]	302	377	483
L8	[mm]	274	305	456
L9	[mm]	180	198	288
L10	[mm]	4	5	5
L11	[mm]	117	129	192
L12	[mm]	157	177	264
L13	[mm]	360	450	576
L14	[mm]	135	175	216
L15	[mm]	225	275	360
L16	[mm]	160	190	250
L17	[mm]	70	75	112
L18	[mm]	107	142	171.25
D1	[mm]	145	155	230
D2 (H7)	[mm]	65	75	100
D3	[mm]	80	90	140
D4	[mm]	185	230	300
T1	[mm]	M16	M20	M20
T2	[mm]	17	22	28
T3	[mm]	6-M16	6-M20	8-M20
V1 ~ V6	Motor attachment dimensions are made to fit your servo motor.			

EJL SERIES Right-angle Worm

EJL Dimensions – Solid Output Shaft - Single and Double

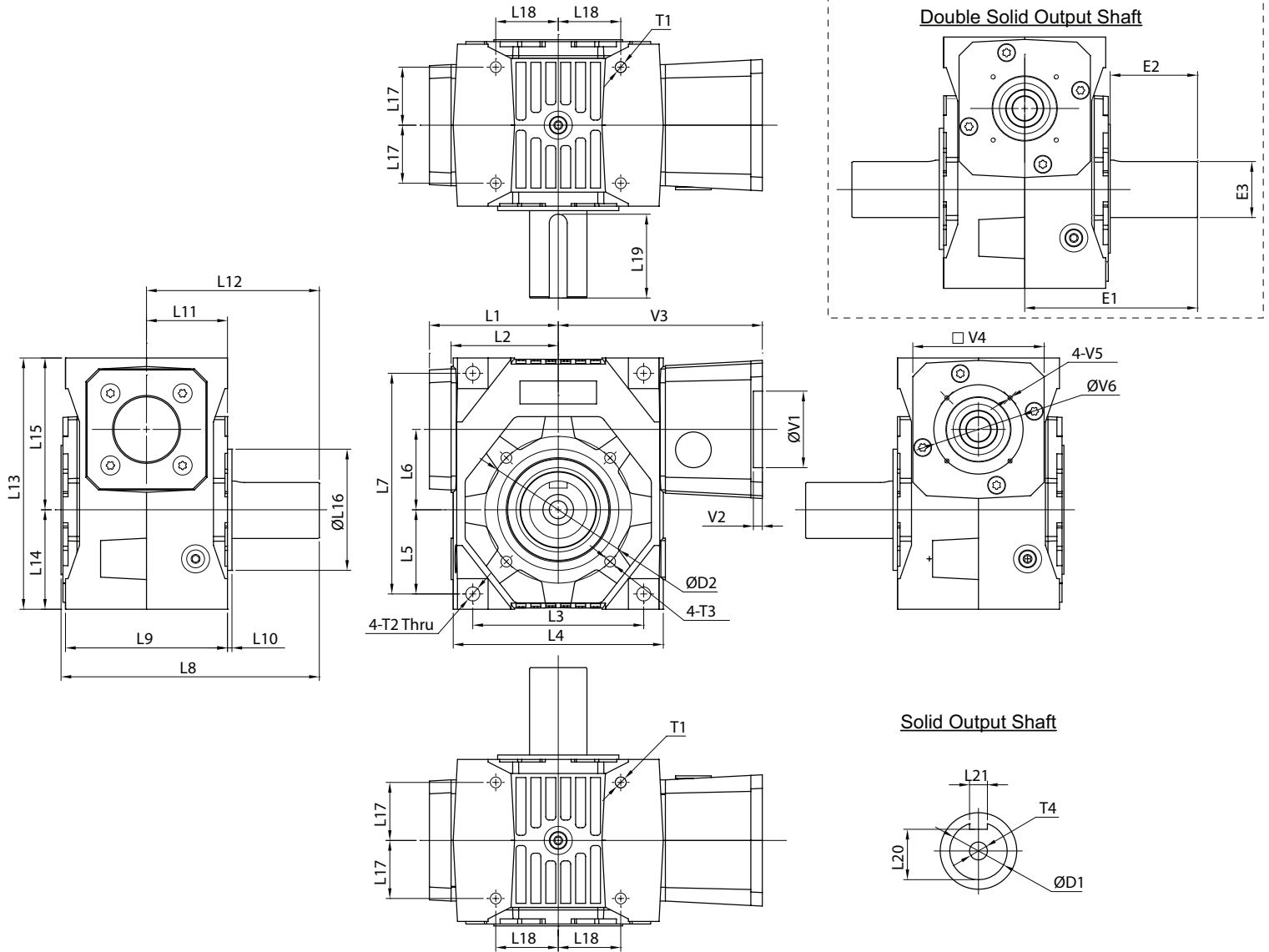

Frame Size	Unit	EJL35	EJL45	EJL55	EJL63	EJL75	EJL90	EJL110
L1	[mm]	70	83.5	91	101	124	136.5	152
L2	[mm]	55	67.5	75	84	104	114.5	132
L3	[mm]	86	108	120	134	172	186	220
L4	[mm]	107	132	146	165	204	225	260
L5	[mm]	44.5	53	61	66	82	91	108
L6	[mm]	35	45	55	63	75	90	110
L7	[mm]	110	135	155	173	208	234	276
L8	[mm]	129	160	178	203	229	276	304
L9	[mm]	86	100	112	127	148	170	182
L10	[mm]	3.0	3.0	3.5	3.5	4	4	5
L11	[mm]	45	50	58	63.5	74	85	91
L12	[mm]	83	107	118	135.5	151	187	208
L13	[mm]	126	153	175	197	232	264	306
L14	[mm]	52.5	62	71	78	94	106	123
L15	[mm]	73.5	91	104	119	138	158	183

EJL Dimensions – Solid Output Shaft - Single and Double

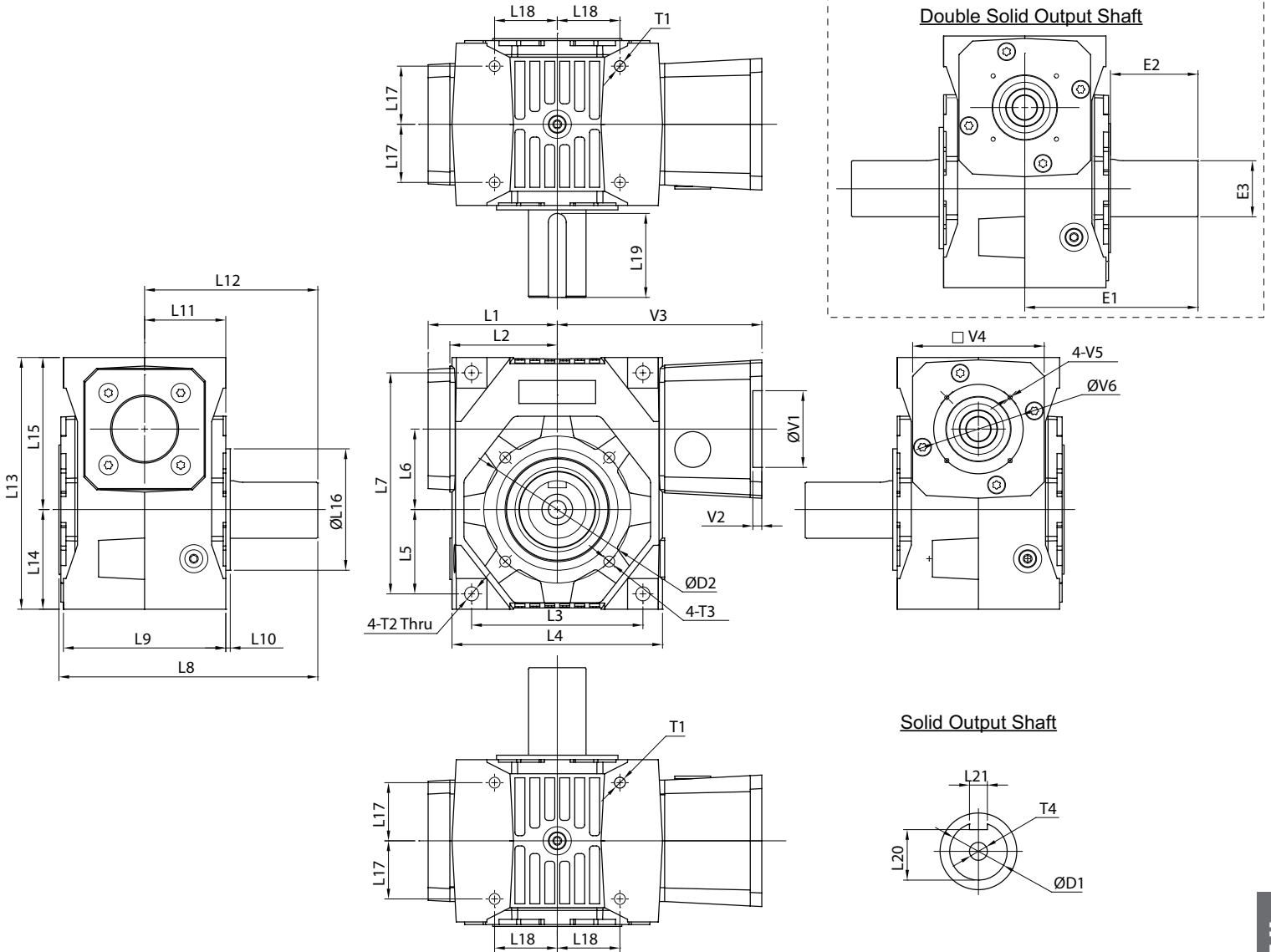

Frame Size	Unit	EJL35	EJL45	EJL55	EJL63	EJL75	EJL90	EJL110
L16 (j7)	[mm]	50	70	80	95	110	130	165
L17	[mm]	28	34	39	45.5	55	65	70
L18	[mm]	31	40.5	45	49	68	70.5	87.5
L19	[mm]	35	50	55	65	70	95.5	110
L20	[mm]	21	30	35	39.5	44.5	58.0	67.5
L21	[mm]	8	10	12	14	14	18	20
D1 (h6)	[mm]	25	35	40	45	50	65	75
D2	[mm]	65	85	100	115	130	165	200
T1	[mm]	M6	M8	M8	M10	M10	M12	M12
T2	[mm]	7	9	9	11	11	13	13
T3	[mm]	M6	M8	M8	M10	4-M10	4-M12	8-M12
T4	[mm]	M10	M12	M16	M16	M16	M20	M20
E1	[mm]	83	107	118	135.5	151	187	208
E2	[mm]	38(*)	55(*)	60(*)	70	75	100	115
E3 (h6)	[mm]	25	35	40	45	50	65	75
V1 ~ V6	Motor attachment dimensions are made to fit your servo motor.							

EJL SERIES Right-angle Worm

EJL Dimensions – Solid Output Shaft - Single Only

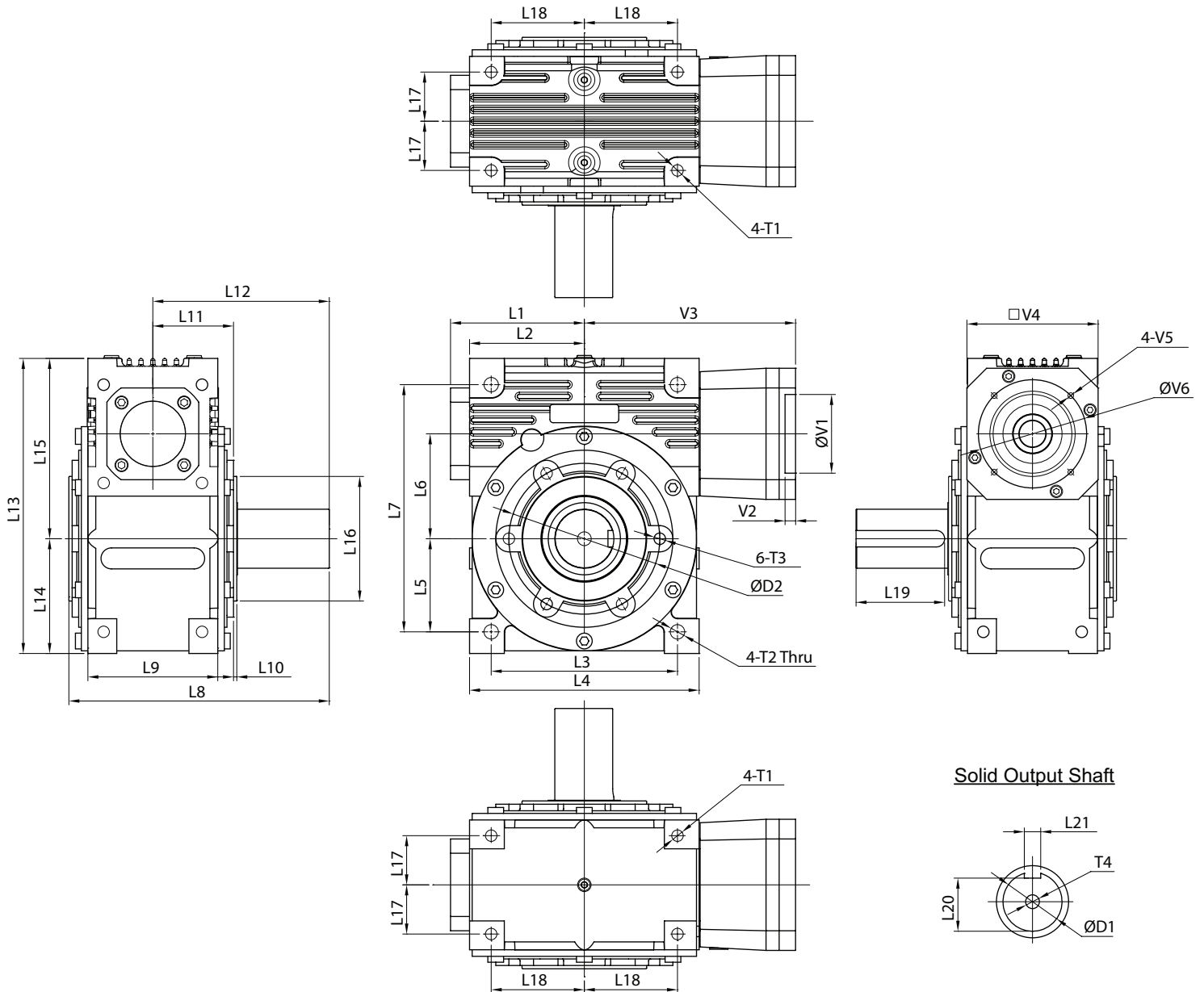

Frame Size	Unit	EJL125	EJL160	EJL200
L1	[mm]	163	204	251
L2	[mm]	135	175	216
L3	[mm]	214	284	342.5
L4	[mm]	270	350	432
L5	[mm]	107	142	171
L6	[mm]	125	160	200
L7	[mm]	302	377	483
L8	[mm]	348	397	551
L9	[mm]	180	198	288
L10	[mm]	4	5	5
L11	[mm]	111	123	187
L12	[mm]	233	269	359
L13	[mm]	360	450	576
L14	[mm]	135	175	216

EJL Dimensions – Solid Output Shaft - Single Only

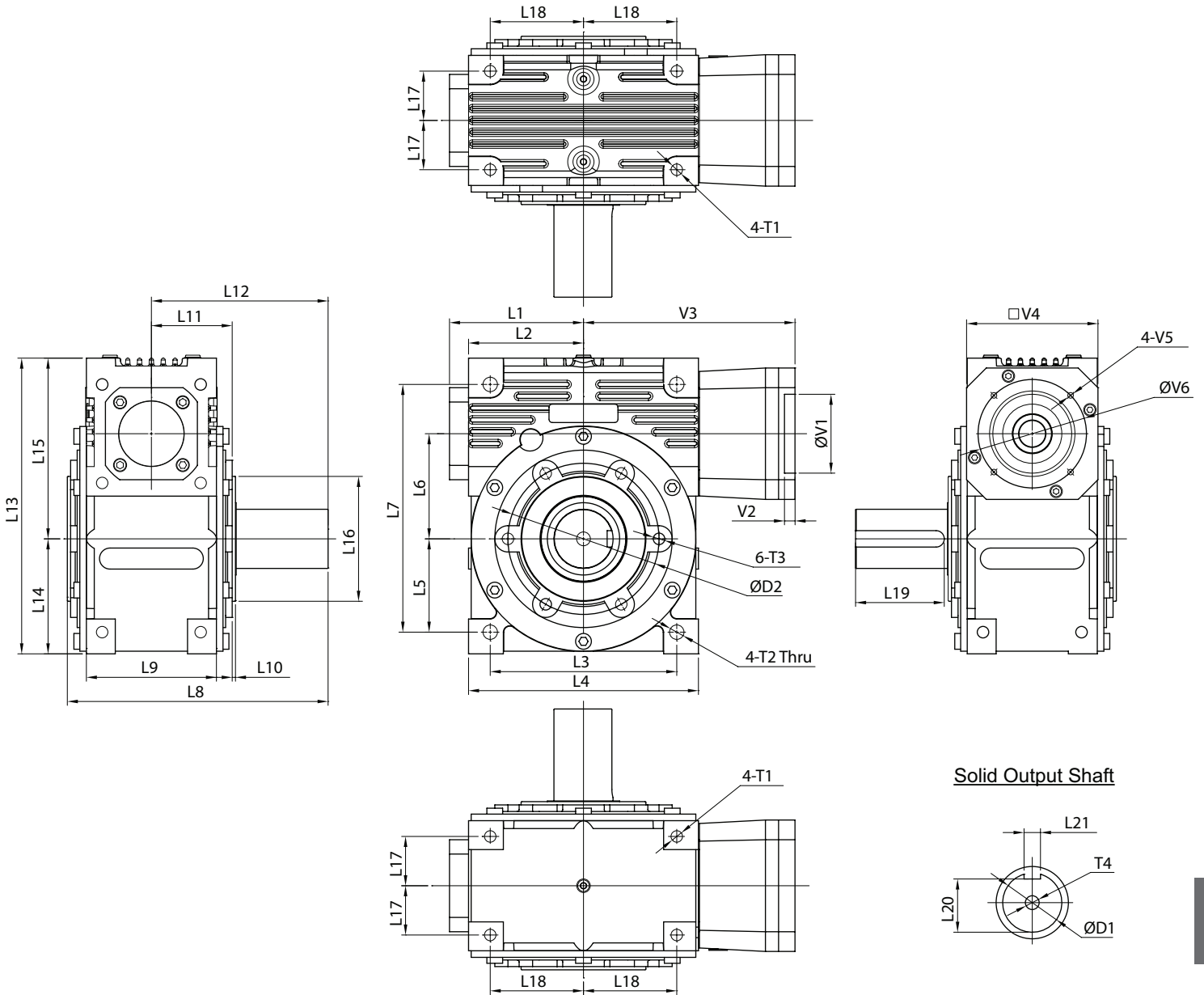

Frame Size	Unit	EJL125	EJL160	EJL200
L15	[mm]	225	275	360
L16 (j7)	[mm]	160	190	250
L17	[mm]	70	75	112
L18	[mm]	107	142	171.25
L19	[mm]	111	135	164
L20	[mm]	67.5	81.0	109.0
L21	[mm]	20.0	25.0	32.0
D1 (h6)	[mm]	75	90	120
D2	[mm]	185	230	300
T1	[mm]	M16	M20	M20
T2	[mm]	17	22	28
T3	[mm]	M16	M20	M20
T4	[mm]	M20	M24	M24
V1 ~ V6	Motor attachment dimensions are made to fit your servo motor.			

EJL SERIES Right-angle Worm

EJL Dimensions – Robot Flange

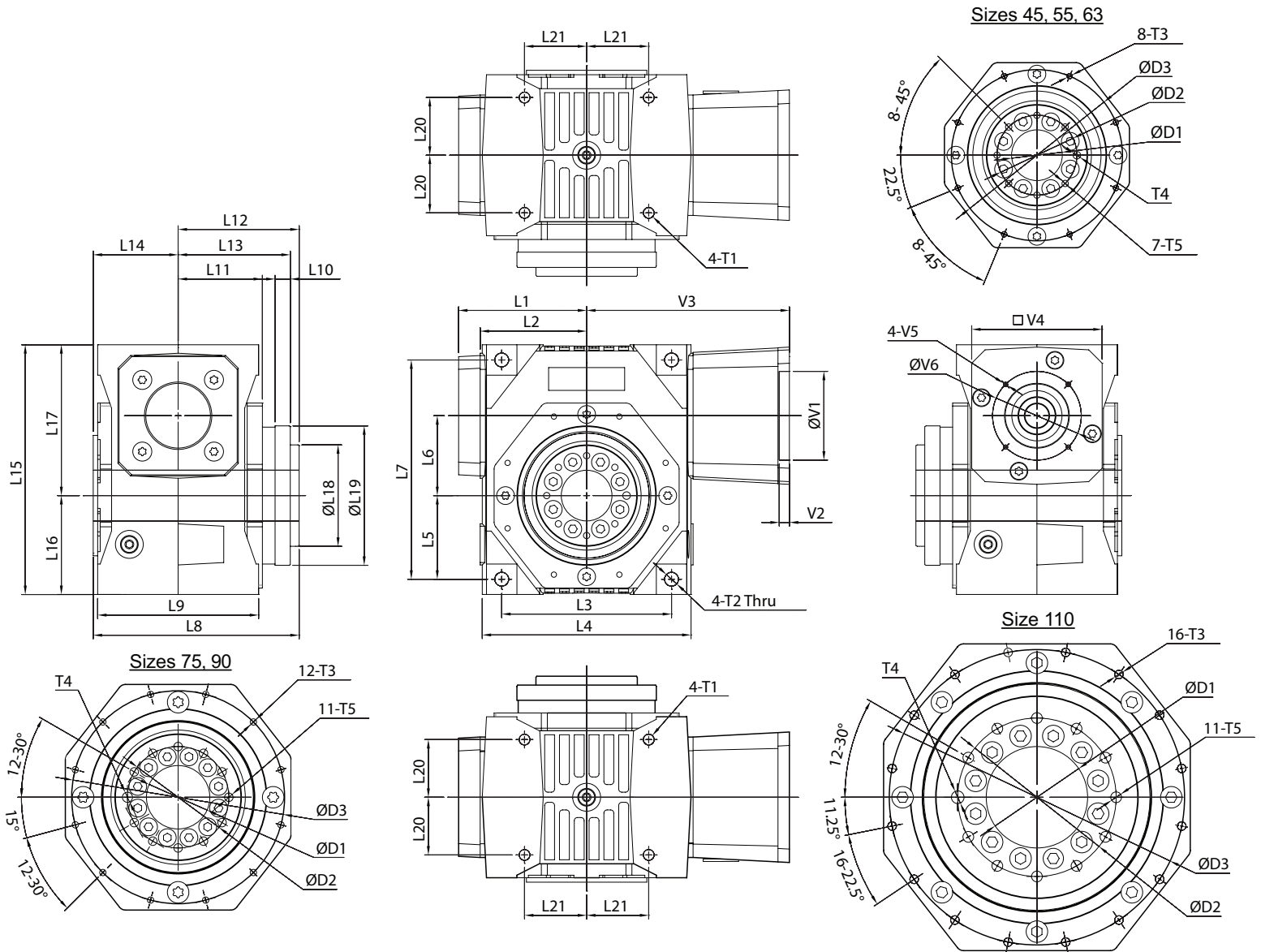

Frame Size	Unit	EJL45	EJL55	EJL63	EJL75	EJL90	EJL110
L1	[mm]	83.5	91.0	101.0	124.0	136.5	152.0
L2	[mm]	67.5	75.0	84.0	104.0	114.5	132.0
L3	[mm]	108	120	134	172	186	220
L4	[mm]	132	146	165	204	225	260
L5	[mm]	53	61	66	82	91	108
L6	[mm]	45	55	63	75	90	110
L7	[mm]	135	155	173	208	234	276
L8	[mm]	133.0	148.5	162.5	195	227	246
L9	[mm]	100	112	127	148	170	182
L10	[mm]	10	12	12	15	18	22
L11	[mm]	54.0	59.0	66.5	79	93	100
L12	[mm]	80.0	89.0	95.5	117	138	150
L13	[mm]	74.0	82.0	88.5	110	129	140
L14	[mm]	53.0	59.5	67.0	78	89	96
L15	[mm]	153	175	197	232	264	306

EJL Dimensions – Robot Flange

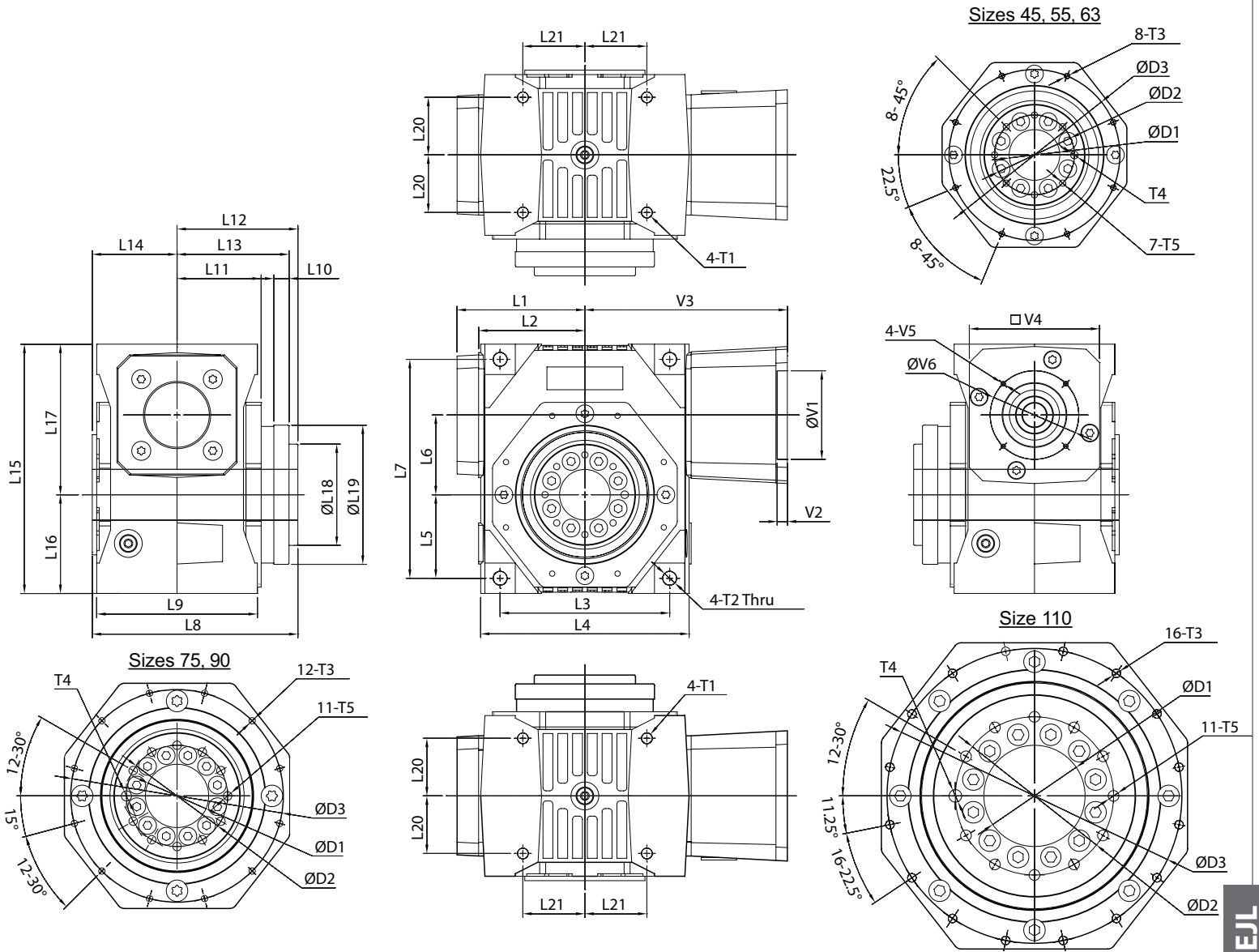

Frame Size	Unit	EJL45	EJL55	EJL63	EJL75	EJL90	EJL110
L16	[mm]	62	71	78	94	106	123
L17	[mm]	91	104	119	138	158	183
L18 (h7)	[mm]	50	63	80	100	125	160
L19 (h7)	[mm]	80	90	110	140	165	200
L20	[mm]	34.0	39.0	45.5	55	65	70
L21	[mm]	40.5	45.0	49.0	68	71	88
D1 (H7)	[mm]	25.0	31.5	40.0	50	63	80
D2	[mm]	40	50	63	80	100	125
D3	[mm]	100	109	135	168	190	233
T1	[mm]	M8	M8	M10	M10	M12	M12
T2	[mm]	9	9	11	11	13	13
T3	[mm]	M5-12 Depth	M5-12 Depth	M5-12 Depth	M6-15 Depth	M8-18 Depth	M8-19 Depth
T4 (H7)	[mm]	6	6	6	8	8	10
T5	[mm]	M6-11 Depth	M6-11 Depth	M6-11 Depth	M8-15 Depth	M8-15 Depth	M10-15 Depth
V1 ~ V6	Motor attachment dimensions are made to fit your servo motor.						