

EJH SERIES

With its cast iron housing design, the EJH is a rugged, reliable performer for any dynamic servo application. This product is an ideal fit for machine builders transitioning from mechanical or hydraulic systems to all-electric servo drives. Unlike traditional worm gearboxes out on the market, the EJH utilizes a globoidal gear mesh, resulting in 300% shock load capacity and a quiet, smooth running drive.

With torque capability up to 7800 in. lb. and backlash as low as 6 arc-min, the EJH is well suited for metals, plastics or rubber processing machinery applications requiring a robust, compact solution. Nidec Drive Technology Corporation can customize this product to fit your needs by offering a variety of solid shaft, hollow shaft or shrink disc output mounting options.

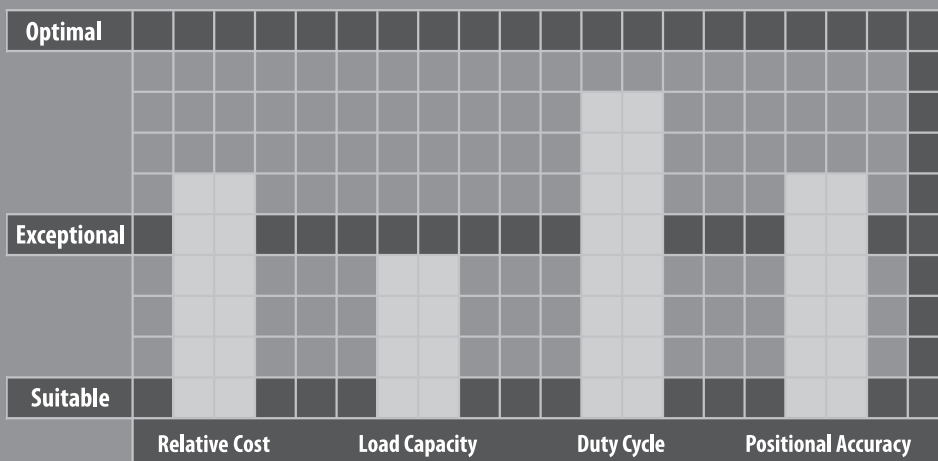



EJH SERIES

- Compact design – exact reduction ratios from 5:1 – 60:1 available in a single stage
- Mid-range performance with backlash as low as 6 arc-min
- Robust cast iron housing design for heavy industry applications
- Five frame sizes to choose from with nominal output torque up to 475Nm

EJH SERIES Right-angle Worm

EJH Series Features

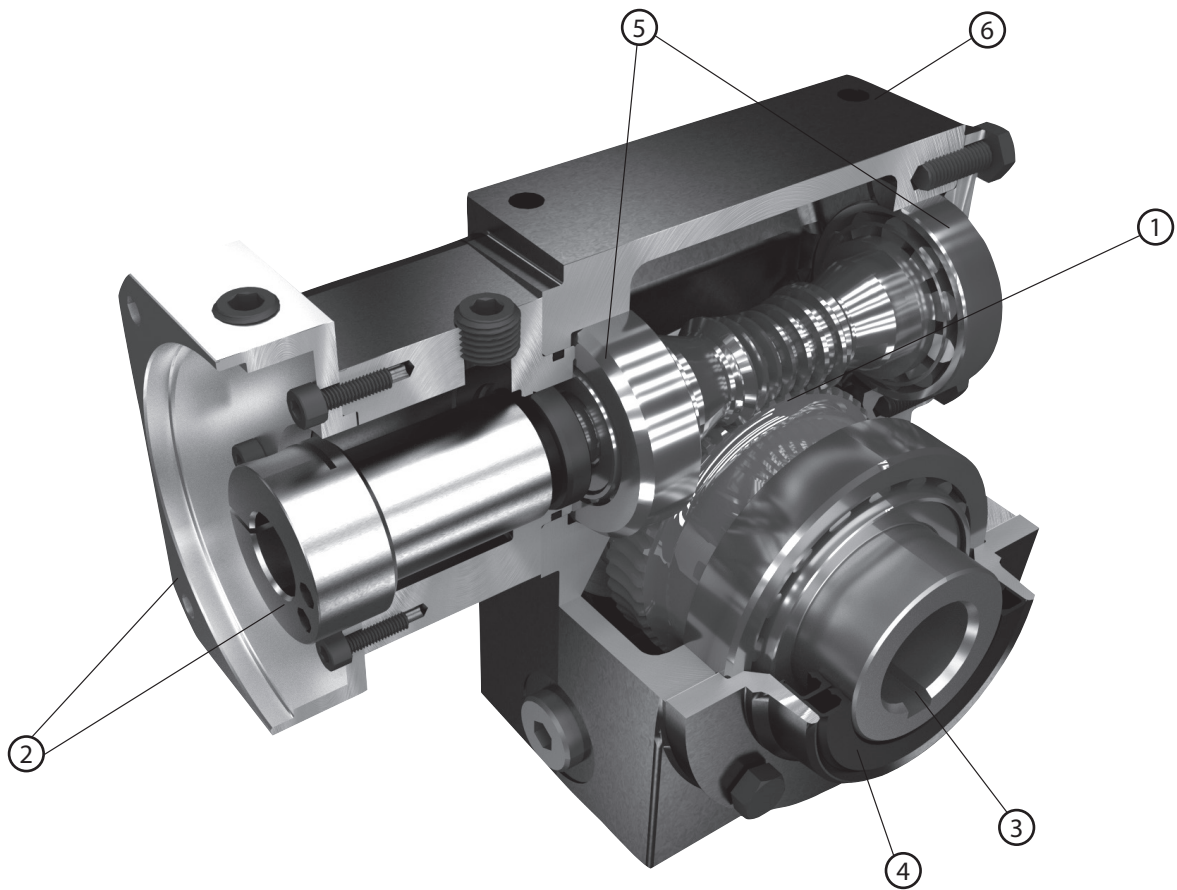

- ① Globoidal gear set – between 3-8 teeth in contact at once, allowing 300% shock load capacity
- ② Adapter-bushing connection allows simple mounting to virtually any servomotor manufacturer
- ③ Wide range of output mounting styles available—hollow shaft, solid shaft, flange mount, shrink disc
- ④ Double oil seal and o-ring provide IP65 protection
- ⑤ Tapered roller bearings provide high radial and thrust load capability
- ⑥ Cast iron housing for improved durability in heavy industrial applications

EJH Series Model Code

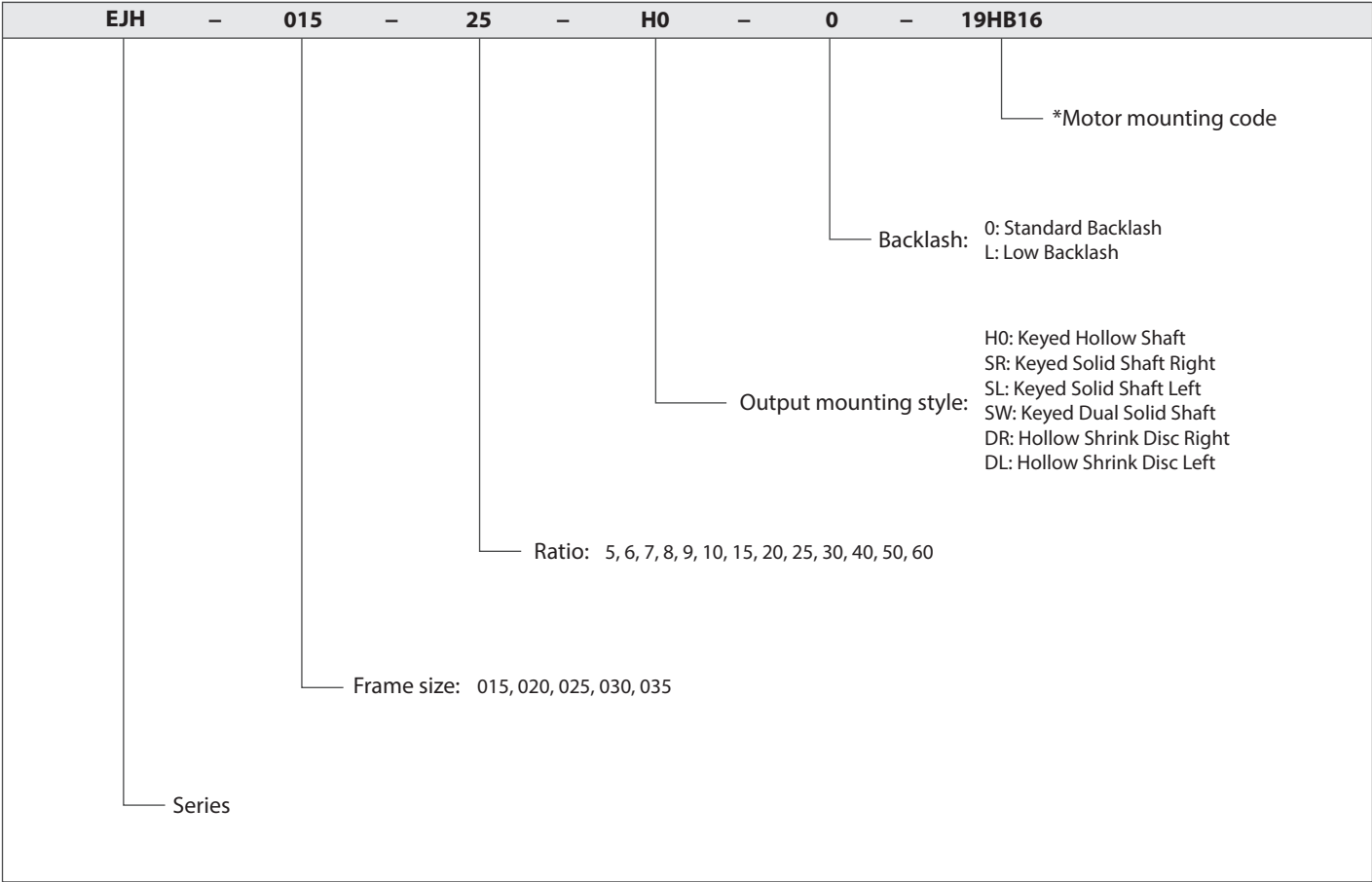

* Motor mounting code varies depending on the motor. Contact us to configure the code.

EJH 015 1-Stage Specifications

Frame Size	015								
Ratio	Unit	Note	5	6	7	8	9	10	15
Nominal Output Torque	[Nm]	--	35	---	---	---	---	47	48
Maximum Acceleration Torque	[Nm]	--	46	---	---	---	---	59	61
Emergency Stop Torque	[Nm]	--	183	---	---	---	---	217	216
No Load Running Torque	[Nm]	*1	0.51						
Nominal Input Speed	[rpm]	--	2,000						
Maximum Continuous Input Speed	[rpm]	--	4,000						
Maximum Cyclic Input Speed	[rpm]	--	4,000						
Maximum Radial Load	[N]	*2	3,110						
Maximum Axial Load	[N]	*3	1,780						
Moment of Inertia ($\leq \varnothing 14$)	[kgcm ²]	--	0.75	---	---	---	---	0.59	0.56
Moment of Inertia ($\leq \varnothing 19$)	[kgcm ²]	--	0.95	---	---	---	---	0.79	0.76
Moment of Inertia ($\leq \varnothing 28$)	[kgcm ²]	--	2.13	---	---	---	---	1.97	1.94
Efficiency	[%]	*4	88	---	---	---	---	86	84
Torsional Rigidity	[Nm/arcmin]	--	10.3						
Maximum Torsional Backlash (Standard)	[Arc-min]	--	≤ 32						
Maximum Torsional Backlash (Low)	[Arc-min]	--	≤ 15						
Noise Level	dB [A]	*5	≤ 73						
Ambient Temperature	[°C]	--	-25 ~ 100						
Permitted Housing Temperature	[°C]	--	100						
Protection Class	--	--	IP65						
Lubrication	--	--	Synthetic Oil						
Service Life	[Hours]	--	25,000						
Weight	[kg]	*6	7						

*1) Torque at no load applied to the input shaft at 2,000 rpm

*2) The maximum radial load the gearbox can accept

*3) The maximum axial load the gearbox can accept

*4) The efficiency at the nominal output torque rating

*5) Measured with no load applied to the input shaft at 2,000 rpm

*6) Weight may vary slightly between models

EJH 015 1-Stage Specifications

Frame Size	015							
Ratio	Unit	Note	20	25	30	40	50	60
Nominal Output Torque	[Nm]	--	48	---	46	42	41	38
Maximum Acceleration Torque	[Nm]	--	59	---	57	52	51	48
Emergency Stop Torque	[Nm]	--	209	---	192	148	150	128
No Load Running Torque	[Nm]	*1	0.51					
Nominal Input Speed	[rpm]	--	2,000					
Maximum Continuous Input Speed	[rpm]	--	4,000					
Maximum Cyclic Input Speed	[rpm]	--	4,000					
Maximum Radial Load	[N]	*2	3,110					
Maximum Axial Load	[N]	*3	1,780					
Moment of Inertia ($\leq \varnothing 14$)	[kgcm ²]	--	0.54	---	0.54	0.53	0.53	0.53
Moment of Inertia ($\leq \varnothing 19$)	[kgcm ²]	--	0.74	---	0.74	0.73	0.73	0.73
Moment of Inertia ($\leq \varnothing 28$)	[kgcm ²]	--	1.92	---	1.92	1.91	1.91	1.91
Efficiency	[%]	*4	81	---	76	72	69	66
Torsional Rigidity	[Nm/arcmin]	--	10.3					
Maximum Torsional Backlash (Standard)	[Arc-min]	--	≤ 32					
Maximum Torsional Backlash (Low)	[Arc-min]	--	≤ 15					
Noise Level	dB [A]	*5	≤ 73					
Ambient Temperature	[°C]	--	-25 ~ 100					
Permitted Housing Temperature	[°C]	--	100					
Protection Class	--	--	IP65					
Lubrication	--	--	Synthetic Oil					
Service Life	[Hours]	--	25,000					
Weight	[kg]	*6	7					

*1) Torque at no load applied to the input shaft at 2,000 rpm

*2) The maximum radial load the gearbox can accept

*3) The maximum axial load the gearbox can accept

*4) The efficiency at the nominal output torque rating

*5) Measured with no load applied to the input shaft at 2,000 rpm

*6) Weight may vary slightly between models

EJH 020 1-Stage Specifications

Frame Size	020										
Ratio	Unit	Note	5	6	7	8	9	10	15		
Nominal Output Torque	[Nm]	--	67	73	78	82	84	86	89		
Maximum Acceleration Torque	[Nm]	--	90	99	105	111	113	115	120		
Emergency Stop Torque	[Nm]	--	384	407	429	441	441	441	452		
No Load Running Torque	[Nm]	*1	1.61								
Nominal Input Speed	[rpm]	--	2,000								
Maximum Continuous Input Speed	[rpm]	--	4,000								
Maximum Cyclic Input Speed	[rpm]	--	4,000								
Maximum Radial Load	[N]	*2	6,670								
Maximum Axial Load	[N]	*3	1,820								
Moment of Inertia ($\leq \varnothing 14$)	[kgcm ²]	--	1.52	1.28	1.14	1.04	0.98	0.94	0.83		
Moment of Inertia ($\leq \varnothing 19$)	[kgcm ²]	--	1.72	1.48	1.34	1.24	1.18	1.14	1.03		
Moment of Inertia ($\leq \varnothing 28$)	[kgcm ²]	--	2.89	2.66	2.52	2.42	2.36	2.31	2.21		
Efficiency	[%]	*4	92	91	91	91	90	90	88		
Torsional Rigidity	[Nm/arcmin]	--	17.8								
Maximum Torsional Backlash (Standard)	[Arc-min]	--	≤ 24								
Maximum Torsional Backlash (Low)	[Arc-min]	--	≤ 11								
Noise Level	dB [A]	*5	≤ 75								
Ambient Temperature	[°C]	--	-25 ~ 100								
Permitted Housing Temperature	[°C]	--	100								
Protection Class	--	--	IP65								
Lubrication	--	--	Synthetic Oil								
Service Life	[Hours]	--	25,000								
Weight	[kg]	*6	12								

*1) Torque at no load applied to the input shaft at 2,000 rpm

*2) The maximum radial load the gearbox can accept

*3) The maximum axial load the gearbox can accept

*4) The efficiency at the nominal output torque rating

*5) Measured with no load applied to the input shaft at 2,000 rpm

*6) Weight may vary slightly between models

EJH 020 1-Stage Specifications

Frame Size	020							
Ratio	Unit	Note	20	25	30	40	50	60
Nominal Output Torque	[Nm]	--	89	88	85	81	78	75
Maximum Acceleration Torque	[Nm]	--	116	116	112	106	102	98
Emergency Stop Torque	[Nm]	--	418	418	395	362	305	294
No Load Running Torque	[Nm]	*1	1.61					
Nominal Input Speed	[rpm]	--	2,000					
Maximum Continuous Input Speed	[rpm]	--	4,000					
Maximum Cyclic Input Speed	[rpm]	--	4,000					
Maximum Radial Load	[N]	*2	6,670					
Maximum Axial Load	[N]	*3	1,820					
Moment of Inertia (≤ Ø14)	[kgcm ²]	--	0.79	0.77	0.76	0.75	0.75	0.75
Moment of Inertia (≤ Ø19)	[kgcm ²]	--	0.99	0.97	0.96	0.95	0.95	0.95
Moment of Inertia (≤ Ø28)	[kgcm ²]	--	2.17	2.15	2.14	2.13	2.13	2.13
Efficiency	[%]	*4	85	84	80	76	73	70
Torsional Rigidity	[Nm/arcmin]	--	17.8					
Maximum Torsional Backlash (Standard)	[Arc-min]	--	≤ 24					
Maximum Torsional Backlash (Low)	[Arc-min]	--	≤ 11					
Noise Level	dB [A]	*5	≤ 75					
Ambient Temperature	[°C]	--	-25 ~ 100					
Permitted Housing Temperature	[°C]	--	100					
Protection Class	--	--	IP65					
Lubrication	--	--	Synthetic Oil					
Service Life	[Hours]	--	25,000					
Weight	[kg]	*6	12					

*1) Torque at no load applied to the input shaft at 2,000 rpm

*2) The maximum radial load the gearbox can accept

*3) The maximum axial load the gearbox can accept

*4) The efficiency at the nominal output torque rating

*5) Measured with no load applied to the input shaft at 2,000 rpm

*6) Weight may vary slightly between models

EJH 025 1-Stage Specifications

Frame Size	025								
Ratio	Unit	Note	5	6	7	8	9	10	15
Nominal Output Torque	[Nm]	--	120	133	140	148	151	155	161
Maximum Acceleration Torque	[Nm]	--	167	184	194	205	209	214	222
Emergency Stop Torque	[Nm]	--	746	802	825	859	870	881	881
No Load Running Torque	[Nm]	*1	2.72						
Nominal Input Speed	[rpm]	--	2,000						
Maximum Continuous Input Speed	[rpm]	--	4,000						
Maximum Cyclic Input Speed	[rpm]	--	4,000						
Maximum Radial Load	[N]	*2	8,890						
Maximum Axial Load	[N]	*3	1,860						
Moment of Inertia ($\leq \varnothing 19$)	[kgcm ²]	--	5.42	4.66	4.20	3.90	3.69	3.54	3.20
Moment of Inertia ($\leq \varnothing 28$)	[kgcm ²]	--	6.24	5.48	5.02	4.72	4.51	4.36	4.02
Moment of Inertia ($\leq \varnothing 38$)	[kgcm ²]	--	11.8	11.1	10.6	10.3	10.1	9.94	9.60
Efficiency	[%]	*4	92	92	91	91	90	90	88
Torsional Rigidity	[Nm/arcmin]	--	23.1						
Maximum Torsional Backlash (Standard)	[Arc-min]	--	≤ 19						
Maximum Torsional Backlash (Low)	[Arc-min]	--	≤ 9						
Noise Level	dB [A]	*5	≤ 80						
Ambient Temperature	[°C]	--	-25 ~ 100						
Permitted Housing Temperature	[°C]	--	100						
Protection Class	--	--	IP65						
Lubrication	--	--	Synthetic Oil						
Service Life	[Hours]	--	25,000						
Weight	[kg]	*6	20						

*1) Torque at no load applied to the input shaft at 2,000 rpm

*2) The maximum radial load the gearbox can accept

*3) The maximum axial load the gearbox can accept

*4) The efficiency at the nominal output torque rating

*5) Measured with no load applied to the input shaft at 2,000 rpm

*6) Weight may vary slightly between models

EJH 025 1-Stage Specifications

Frame Size	025							
Ratio	Unit	Note	20	25	30	40	50	60
Nominal Output Torque	[Nm]	--	159	159	152	145	140	134
Maximum Acceleration Torque	[Nm]	--	217	217	208	198	191	183
Emergency Stop Torque	[Nm]	--	847	791	780	678	621	610
No Load Running Torque	[Nm]	*1	2.72					
Nominal Input Speed	[rpm]	--	2,000					
Maximum Continuous Input Speed	[rpm]	--	4,000					
Maximum Cyclic Input Speed	[rpm]	--	4,000					
Maximum Radial Load	[N]	*2	8,890					
Maximum Axial Load	[N]	*3	1,860					
Moment of Inertia (≤ Ø19)	[kgcm ²]	--	3.07	3.02	2.99	2.96	2.94	2.93
Moment of Inertia (≤ Ø28)	[kgcm ²]	--	3.89	3.84	3.81	3.78	3.76	3.75
Moment of Inertia (≤ Ø38)	[kgcm ²]	--	9.47	9.42	9.39	9.36	9.34	9.33
Efficiency	[%]	*4	85	84	80	76	73	70
Torsional Rigidity	[Nm/arcmin]	--	23.1					
Maximum Torsional Backlash (Standard)	[Arc-min]	--	≤ 19					
Maximum Torsional Backlash (Low)	[Arc-min]	--	≤ 9					
Noise Level	dB [A]	*5	≤ 80					
Ambient Temperature	[°C]	--	-25 ~ 100					
Permitted Housing Temperature	[°C]	--	100					
Protection Class	--	--	IP65					
Lubrication	--	--	Synthetic Oil					
Service Life	[Hours]	--	25,000					
Weight	[kg]	*6	20					

*1) Torque at no load applied to the input shaft at 2,000 rpm

*2) The maximum radial load the gearbox can accept

*3) The maximum axial load the gearbox can accept

*4) The efficiency at the nominal output torque rating

*5) Measured with no load applied to the input shaft at 2,000 rpm

*6) Weight may vary slightly between models

EJH 030 1-Stage Specifications

Frame Size	030									
Ratio	Unit	Note	5	6	7	8	9	10	15	
Nominal Output Torque	[Nm]	--	196	219	233	248	255	264	275	
Maximum Acceleration Torque	[Nm]	--	275	306	324	345	355	367	381	
Emergency Stop Torque	[Nm]	--	1,311	1,424	1,480	1,548	1,548	1,559	1,570	
No Load Running Torque	[Nm]	*1							3.46	
Nominal Input Speed	[rpm]	--							2,000	
Maximum Continuous Input Speed	[rpm]	--							4,000	
Maximum Cyclic Input Speed	[rpm]	--							4,000	
Maximum Radial Load	[N]	*2							11,110	
Maximum Axial Load	[N]	*3							4,220	
Moment of Inertia ($\leq \varnothing 19$)	[kgcm ²]	--	13.3	11.1	9.80	8.94	8.35	7.92	6.92	
Moment of Inertia ($\leq \varnothing 28$)	[kgcm ²]	--	16.2	14.0	12.7	11.8	11.2	10.8	9.78	
Moment of Inertia ($\leq \varnothing 38$)	[kgcm ²]	--	19.9	17.7	16.3	15.5	14.9	14.5	13.5	
Efficiency	[%]	*4	92	92	91	91	90	89	88	
Torsional Rigidity	[Nm/arcmin]	--							41.6	
Maximum Torsional Backlash (Standard)	[Arc-min]	--							≤ 16	
Maximum Torsional Backlash (Low)	[Arc-min]	--							≤ 7	
Noise Level	dB [A]	*5							≤ 80	
Ambient Temperature	[°C]	--							-25 ~ 100	
Permitted Housing Temperature	[°C]	--							100	
Protection Class	--	--							IP65	
Lubrication	--	--							Synthetic Oil	
Service Life	[Hours]	--							25,000	
Weight	[kg]	*6							35	

*1) Torque at no load applied to the input shaft at 2,000 rpm

*2) The maximum radial load the gearbox can accept

*3) The maximum axial load the gearbox can accept

*4) The efficiency at the nominal output torque rating

*5) Measured with no load applied to the input shaft at 2,000 rpm

*6) Weight may vary slightly between models

EJH 030 1-Stage Specifications

Frame Size	030							
Ratio	Unit	Note	20	25	30	40	50	60
Nominal Output Torque	[Nm]	--	272	272	260	248	239	230
Maximum Acceleration Torque	[Nm]	--	373	373	357	341	328	315
Emergency Stop Torque	[Nm]	--	1,503	1,435	1,390	1,254	1,096	1,085
No Load Running Torque	[Nm]	*1	3.46					
Nominal Input Speed	[rpm]	--	2,000					
Maximum Continuous Input Speed	[rpm]	--	4,000					
Maximum Cyclic Input Speed	[rpm]	--	4,000					
Maximum Radial Load	[N]	*2	11,110					
Maximum Axial Load	[N]	*3	4,220					
Moment of Inertia (≤ Ø19)	[kgcm ²]	--	6.57	6.41	6.32	6.24	6.19	6.17
Moment of Inertia (≤ Ø28)	[kgcm ²]	--	9.43	9.27	9.18	9.10	9.05	9.03
Moment of Inertia (≤ Ø38)	[kgcm ²]	--	13.1	13.0	12.9	12.8	12.7	12.7
Efficiency	[%]	*4	85	84	80	76	73	70
Torsional Rigidity	[Nm/arcmin]	--	41.6					
Maximum Torsional Backlash (Standard)	[Arc-min]	--	≤ 16					
Maximum Torsional Backlash (Low)	[Arc-min]	--	≤ 7					
Noise Level	dB [A]	*5	≤ 80					
Ambient Temperature	[°C]	--	-25 ~ 100					
Permitted Housing Temperature	[°C]	--	100					
Protection Class	--	--	IP65					
Lubrication	--	--	Synthetic Oil					
Service Life	[Hours]	--	25,000					
Weight	[kg]	*6	35					

*1) Torque at no load applied to the input shaft at 2,000 rpm

*2) The maximum radial load the gearbox can accept

*3) The maximum axial load the gearbox can accept

*4) The efficiency at the nominal output torque rating

*5) Measured with no load applied to the input shaft at 2,000 rpm

*6) Weight may vary slightly between models

EJH 035 1-Stage Specifications

Frame Size	035								
Ratio	Unit	Note	5	6	7	8	9	10	15
Nominal Output Torque	[Nm]	--	341	381	404	430	442	456	475
Maximum Acceleration Torque	[Nm]	--	480	537	568	604	619	638	663
Emergency Stop Torque	[Nm]	--	2,423	2,644	2,731	2,845	2,864	2,889	2,885
No Load Running Torque	[Nm]	*1	4.20						
Nominal Input Speed	[rpm]	--	2,000						
Maximum Continuous Input Speed	[rpm]	--	4,000						
Maximum Cyclic Input Speed	[rpm]	--	4,000						
Maximum Radial Load	[N]	*2	15,560						
Maximum Axial Load	[N]	*3	4,000						
Moment of Inertia ($\leq \varnothing 19$)	[kgcm ²]	--	28.3	23.9	21.2	19.5	18.3	17.4	15.4
Moment of Inertia ($\leq \varnothing 28$)	[kgcm ²]	--	32.3	27.8	25.2	23.4	22.2	21.4	19.4
Moment of Inertia ($\leq \varnothing 38$)	[kgcm ²]	--	36.9	32.5	29.8	28.1	26.9	26.0	24.0
Efficiency	[%]	*4	91	91	91	90	90	89	87
Torsional Rigidity	[Nm/arcmin]	--	79.2						
Maximum Torsional Backlash (Standard)	[Arc-min]	--	≤ 15						
Maximum Torsional Backlash (Low)	[Arc-min]	--	≤ 6						
Noise Level	dB [A]	*5	≤ 83						
Ambient Temperature	[°C]	--	-25 ~ 100						
Permitted Housing Temperature	[°C]	--	100						
Protection Class	--	--	IP65						
Lubrication	--	--	Synthetic Oil						
Service Life	[Hours]	--	25,000						
Weight	[kg]	*6	53						

*1) Torque at no load applied to the input shaft at 2,000 rpm

*2) The maximum radial load the gearbox can accept

*3) The maximum axial load the gearbox can accept

*4) The efficiency at the nominal output torque rating

*5) Measured with no load applied to the input shaft at 2,000 rpm

*6) Weight may vary slightly between models

EJH 035 1-Stage Specifications

Frame Size	035							
Ratio	Unit	Note	20	25	30	40	50	60
Nominal Output Torque	[Nm]	--	471	468	450	429	413	397
Maximum Acceleration Torque	[Nm]	--	649	649	622	593	571	548
Emergency Stop Torque	[Nm]	--	2,819	2,691	2,570	2,293	2,076	2,037
No Load Running Torque	[Nm]	*1	4.20					
Nominal Input Speed	[rpm]	--	2,000					
Maximum Continuous Input Speed	[rpm]	--	4,000					
Maximum Cyclic Input Speed	[rpm]	--	4,000					
Maximum Radial Load	[N]	*2	15,560					
Maximum Axial Load	[N]	*3	4,000					
Moment of Inertia (≤ Ø19)	[kgcm ²]	--	14.7	14.4	14.2	14.0	13.9	13.9
Moment of Inertia (≤ Ø28)	[kgcm ²]	--	18.7	18.3	18.1	18.0	17.9	17.8
Moment of Inertia (≤ Ø38)	[kgcm ²]	--	23.3	23.0	22.8	22.6	22.5	22.5
Efficiency	[%]	*4	84	83	79	75	72	69
Torsional Rigidity	[Nm/arcmin]	--	79.2					
Maximum Torsional Backlash (Standard)	[Arc-min]	--	≤ 15					
Maximum Torsional Backlash (Low)	[Arc-min]	--	≤ 6					
Noise Level	dB [A]	*5	≤ 83					
Ambient Temperature	[°C]	--	-25 ~ 100					
Permitted Housing Temperature	[°C]	--	100					
Protection Class	--	--	IP65					
Lubrication	--	--	Synthetic Oil					
Service Life	[Hours]	--	25,000					
Weight	[kg]	*6	53					

*1) Torque at no load applied to the input shaft at 2,000 rpm

*2) The maximum radial load the gearbox can accept

*3) The maximum axial load the gearbox can accept

*4) The efficiency at the nominal output torque rating

*5) Measured with no load applied to the input shaft at 2,000 rpm

*6) Weight may vary slightly between models

EJH SERIES Right-angle Worm

EJH Dimensions – Hollow Output Shaft

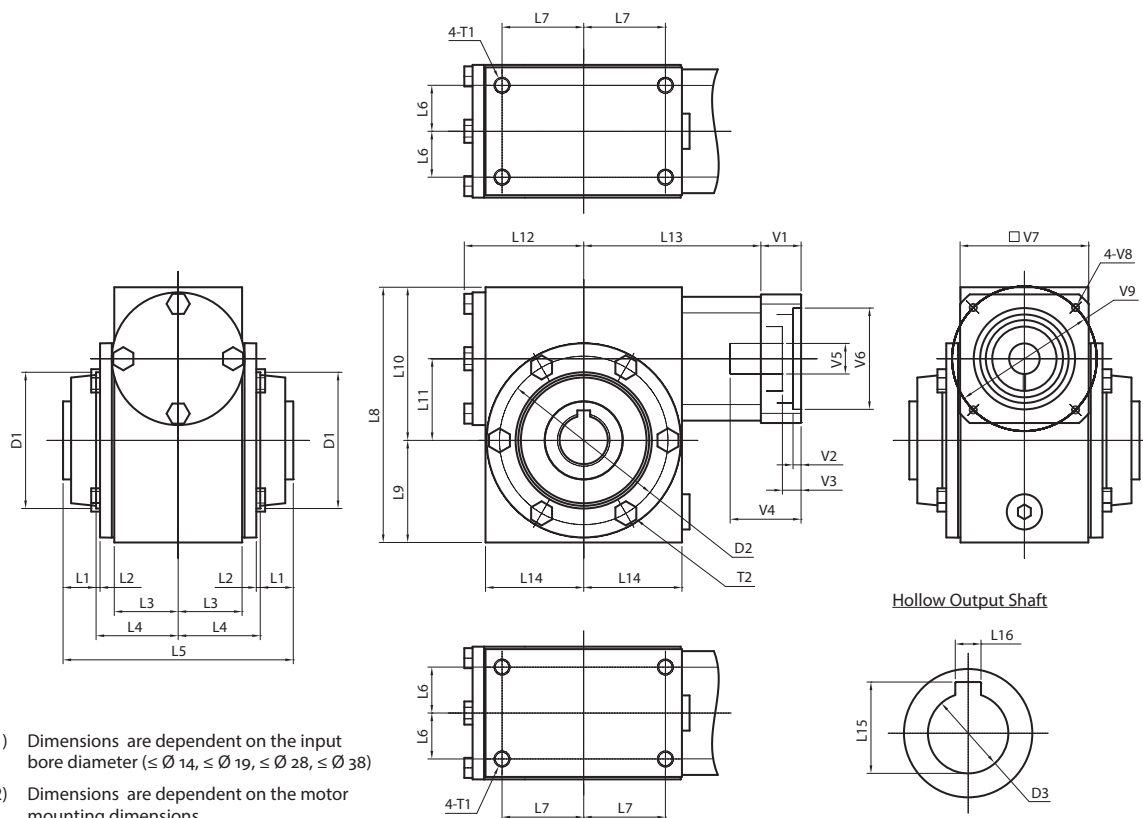

*1) Dimensions are dependent on the input bore diameter ($\leq \varnothing 14$, $\leq \varnothing 19$, $\leq \varnothing 28$, $\leq \varnothing 38$)

*2) Dimensions are dependent on the motor mounting dimensions

Frame Size	Unit	Note	EJH-015	EJH-020	EJH-025	EJH-030	EJH-035
L1	[mm]	--	6.5	15.5	13.5	21.5	15
L2	[mm]	--	3.5	2.5	3	3.5	5
L3	[mm]	--	42	40	49	65	87
L4	[mm]	--	52.5	51	60.5	78.5	102
L5	[mm]	--	118	134	148	200	234
L6	[mm]	--	33.5	28.5	38	49	71.5
L7	[mm]	--	36.5	51	65	81	97
L8	[mm]	--	121	159	191	230	262
L9	[mm]	--	41.5	63.5	76	92	108
L10	[mm]	--	79.5	95.5	115	138	154
L11	[mm]	--	38.1	50.8	63.5	76.2	88.9
L12	[mm]	--	55	73	93	115	131
L13	[mm]	*1	95.5 - 105.5	113.5 - 123.5	137.5 - 149.5	156 - 168	174.5 - 186.5
L14	[mm]	--	45	61	79	98	113
L15	[mm]	--	28.5	33.5	38.5	49	64.5
L16	[mm]	--	8	8	10	14	18
D1 ±0.03	[mm]	--	ø63.45	ø84.73	ø107.11	ø135.69	ø134.26
D2	[mm]	--	ø79.5	ø105	ø125.5	ø155.5	ø184
D3 (H7)	[mm]	--	ø25	ø30	ø35	ø45	ø60
T1	[mm]	--	4xM8x12	4xM10x15	4xM10x15	4xM12x18	4xM12x18
T2	[mm]	--	4xM6 Bolts	4xM8 Bolts	8xM8 Bolts	6xM10 Bolts	6xM10 Bolts
V1 ~ V9	[mm]	*2	Motor attachment dimensions are made to fit your servo motor.				

EJH Dimensions – Solid Output Shaft

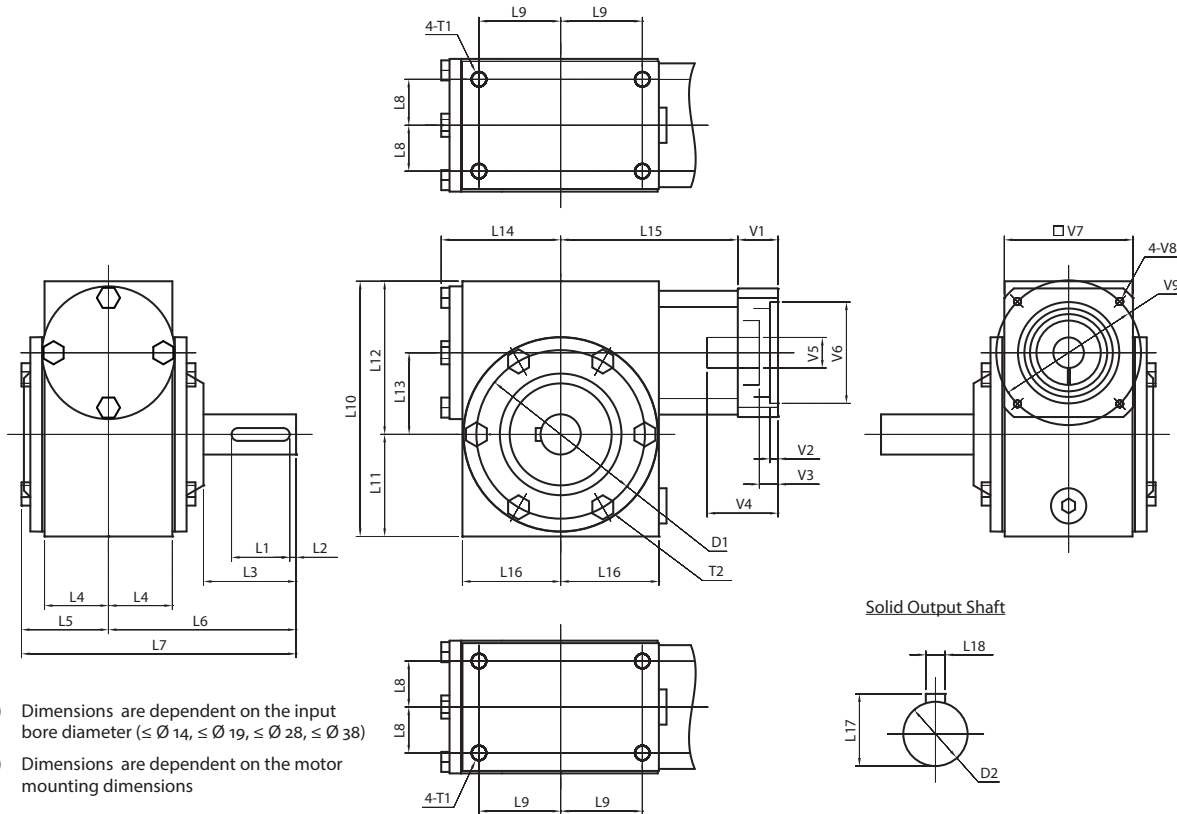

- *1) Dimensions are dependent on the input bore diameter (≤ Ø 14, ≤ Ø 19, ≤ Ø 28, ≤ Ø 38)
- *2) Dimensions are dependent on the motor mounting dimensions

Frame Size	Unit	Note	EJH-015	EJH-020	EJH-025	EJH-030	EJH-035
L1	[mm]	--	22	36	40	50	63
L2	[mm]	--	4	4	3	3	5
L3	[mm]	--	32.5	57.5	55	85.5	97.5
L4	[mm]	--	42	40	49	65	87
L5	[mm]	--	53	54.5	65.5	84	106.5
L6	[mm]	--	89	117.5	121.5	168.5	209.5
L7	[mm]	--	142	172	187	252.5	316
L8	[mm]	--	33.5	28.5	38	49	71.5
L9	[mm]	--	36.5	51	65	81	97
L10	[mm]	--	121	159	191	230	262
L11	[mm]	--	41.5	63.5	76	92	108
L12	[mm]	--	79.5	95.5	115	138	154
L13	[mm]	--	38.1	50.8	63.5	76.2	88.9
L14	[mm]	--	55	73	93	115	131
L15	[mm]	*1	95.5 - 105.5	113.5 - 123.5	137.5 - 149.5	156 - 168	174.5 - 186.5
L16	[mm]	--	45	61	79	98	113
L17	[mm]	--	22.5	28	33	41	48.5
L18	[mm]	--	6	8	8	10	14
D1	[mm]	--	ø79.5	ø105	ø125.5	ø155.5	ø184
D2 (k6)	[mm]	--	ø20	ø25	ø30	ø38	ø45
T1	[mm]	--	4xM8x12	4xM10x15	4xM10x15	4xM12x18	4xM12x18
T2	[mm]	--	4xM6 Bolts	4xM8 Bolts	8xM8 Bolts	6xM10 Bolts	6xM10 Bolts
V1 ~ V9	[mm]	*2	Motor attachment dimensions are made to fit your servo motor.				

EJH SERIES Right-angle Worm

EJH Dimensions – Hollow Output with Shrink Disk

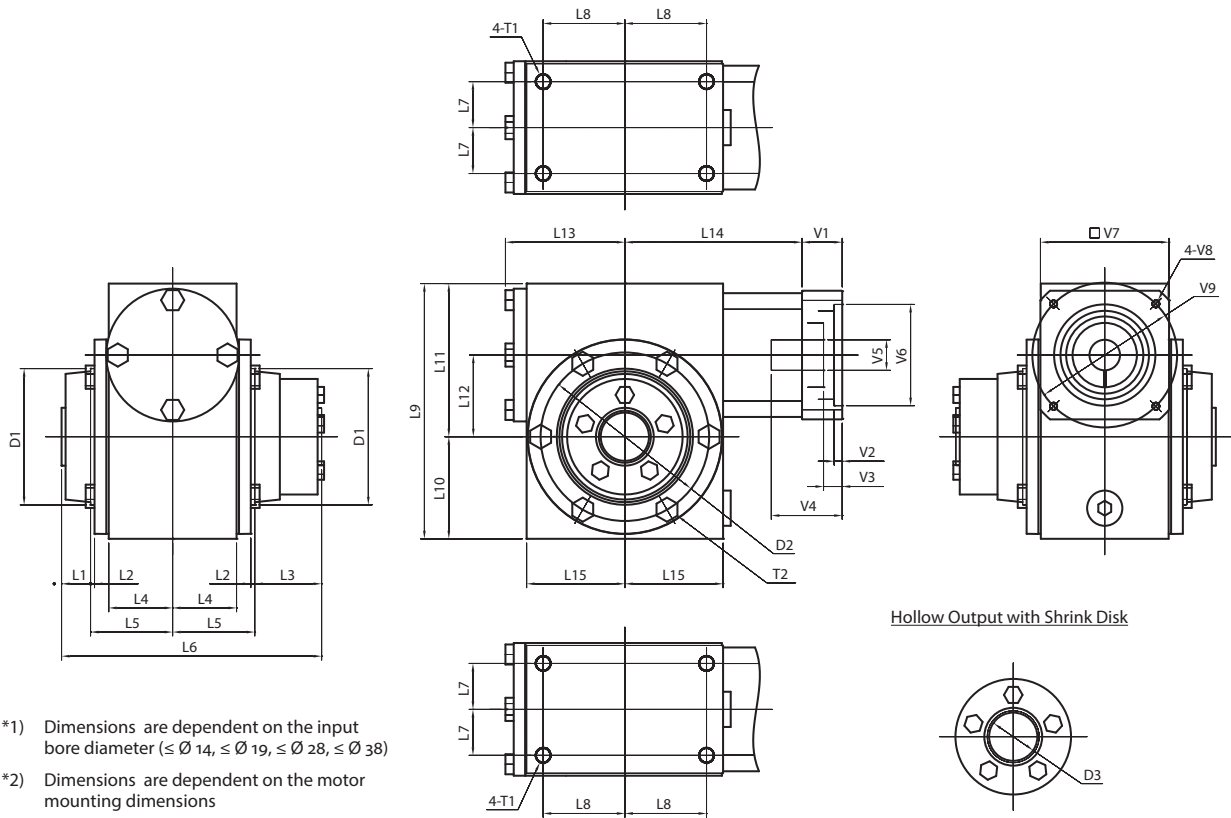

- *1) Dimensions are dependent on the input bore diameter ($\leq \varnothing 14$, $\leq \varnothing 19$, $\leq \varnothing 28$, $\leq \varnothing 38$)
- *2) Dimensions are dependent on the motor mounting dimensions

Frame Size	Unit	Note	EJH-015	EJH-020	EJH-025	EJH-030	EJH-035
L1	[mm]	--	6.5	15.5	13.5	21.5	15
L2	[mm]	--	3.5	2.5	3	3.5	5
L3	[mm]	--	30.5	41.5	48.5	56.5	57
L4	[mm]	--	42	40	49	65	87
L5	[mm]	--	52.5	51	60.5	78.5	101
L6	[mm]	--	141.5	159.5	183	235	271
L7	[mm]	--	33.5	28.5	38	49	71.5
L8	[mm]	--	36.5	51	65	81	97
L9	[mm]	--	121	159	191	230	262
L10	[mm]	--	41.5	63.5	76	92	108
L11	[mm]	--	79.5	95.5	115	138	154
L12	[mm]	--	38.1	50.8	63.5	76.2	88.9
L13	[mm]	--	55	73	93	115	131
L14	[mm]	*1	95.5 - 105.5	113.5 - 123.5	137.5 - 149.5	156 - 168	174.5 - 186.5
L15	[mm]	--	45	61	79	98	113
D1 ± 0.03	[mm]	--	$\varnothing 63.45$	$\varnothing 84.73$	$\varnothing 107.11$	$\varnothing 135.69$	$\varnothing 134.26$
D2	[mm]	--	$\varnothing 79.5$	$\varnothing 105$	$\varnothing 125.5$	$\varnothing 155.5$	$\varnothing 184$
D3 (H7)	[mm]	--	$\varnothing 25$	$\varnothing 30$	$\varnothing 35$	$\varnothing 45$	$\varnothing 60$
T1	[mm]	--	4xM8x12	4xM10x15	4xM10x15	4xM12x18	4xM12x18
T2	[mm]	--	4xM6 Bolts	4xM8 Bolts	8xM8 Bolts	6xM10 Bolts	6xM10 Bolts
V1 ~ V9	[mm]	*2	Motor attachment dimensions are made to fit your servo motor.				

EJH Dimensions – Optional Mounting Flange (*1)

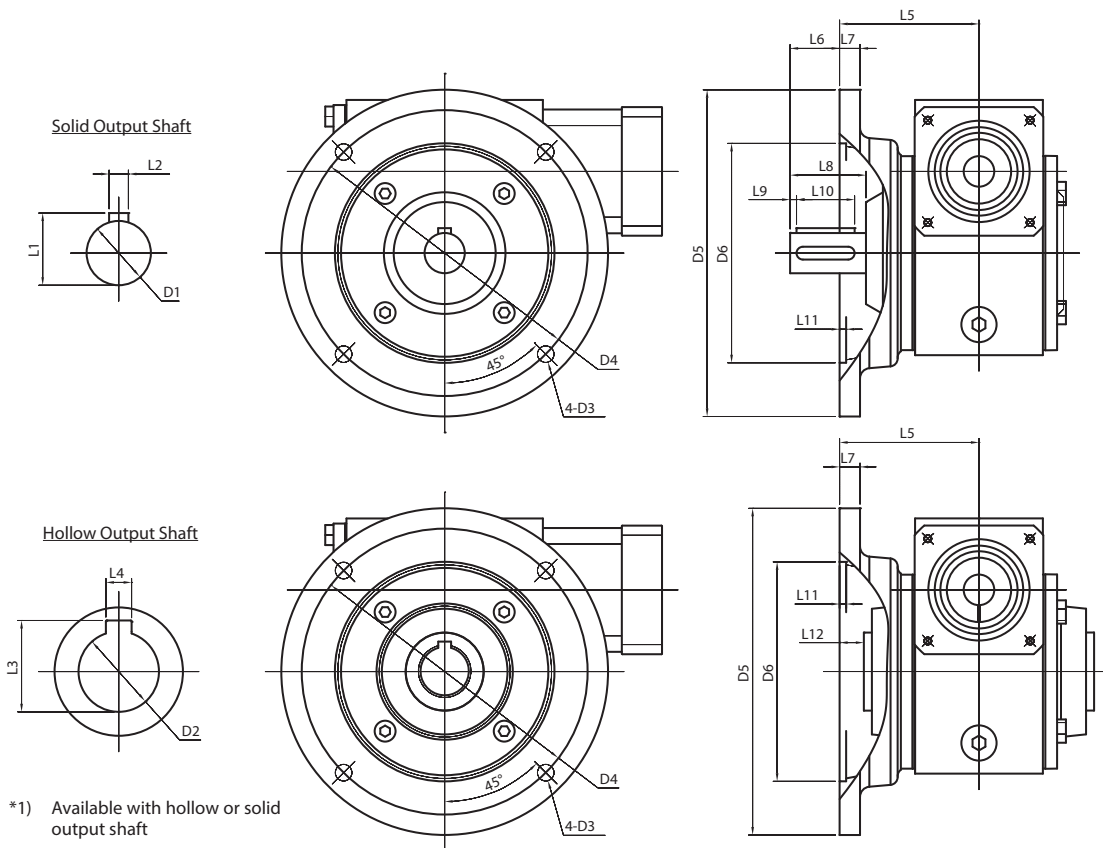

*1) Available with hollow or solid output shaft

Frame Size	Unit	Note	EJH-015	EJH-020	EJH-025	EJH-030	EJH-035
L1	[mm]	--	22.5	28	33	41	48.5
L2	[mm]	--	6	8	8	10	14
L3	[mm]	--	28.5	33.5	38.5	49	64.5
L4	[mm]	--	8	8	10	14	18
L5	[mm]	--	86	87	89	111	129
L6	[mm]	--	2.5	31	32	58	80.5
L7	[mm]	--	10	13	13	13	13
L8	[mm]	--	32.5	57.5	55.0	85.5	97.5
L9	[mm]	--	4	4	3	3	5
L10	[mm]	--	22	36	40	50	63
L11	[mm]	--	4	4	5	7	7
L12	[mm]	--	27.5	20	15.5	10.5	12
D1 (k6)	[mm]	--	ø20	ø25	ø30	ø38	ø45
D2 (H7)	[mm]	--	ø25	ø30	ø35	ø45	ø60
D3	[mm]	--	ø10	ø10	ø12	ø14	ø14
D4	[mm]	--	ø149	ø178	ø210	ø241	ø267
D5	[mm]	--	ø168	ø203	ø235	ø267	ø298
D6 ±0.03	[mm]	--	ø114.30	ø136.55	ø168.30	ø196.88	ø222.28