

## EJH 015 1-Stage Specifications

Frame Size	015								
Ratio	Unit	Note	5	6	7	8	9	10	15
Nominal Output Torque	[Nm]	--	35	---	---	---	---	47	48
Maximum Acceleration Torque	[Nm]	--	46	---	---	---	---	59	61
Emergency Stop Torque	[Nm]	--	183	---	---	---	---	217	216
No Load Running Torque	[Nm]	*1	0.51						
Nominal Input Speed	[rpm]	--	2,000						
Maximum Continuous Input Speed	[rpm]	--	4,000						
Maximum Cyclic Input Speed	[rpm]	--	4,000						
Maximum Radial Load	[N]	*2	3,110						
Maximum Axial Load	[N]	*3	1,780						
Moment of Inertia ( $\leq \varnothing 14$ )	[kgcm <sup>2</sup> ]	--	0.75	---	---	---	---	0.59	0.56
Moment of Inertia ( $\leq \varnothing 19$ )	[kgcm <sup>2</sup> ]	--	0.95	---	---	---	---	0.79	0.76
Moment of Inertia ( $\leq \varnothing 28$ )	[kgcm <sup>2</sup> ]	--	2.13	---	---	---	---	1.97	1.94
Efficiency	[%]	*4	88	---	---	---	---	86	84
Torsional Rigidity	[Nm/arcmin]	--	10.3						
Maximum Torsional Backlash (Standard)	[Arc-min]	--	$\leq 32$						
Maximum Torsional Backlash (Low)	[Arc-min]	--	$\leq 15$						
Noise Level	dB [A]	*5	$\leq 73$						
Ambient Temperature	[°C]	--	-25 ~ 100						
Permitted Housing Temperature	[°C]	--	100						
Protection Class	--	--	IP65						
Lubrication	--	--	Synthetic Oil						
Service Life	[Hours]	--	25,000						
Weight	[kg]	*6	7						

\*1) Torque at no load applied to the input shaft at 2,000 rpm

\*2) The maximum radial load the gearbox can accept

\*3) The maximum axial load the gearbox can accept

\*4) The efficiency at the nominal output torque rating

\*5) Measured with no load applied to the input shaft at 2,000 rpm

\*6) Weight may vary slightly between models

## EJH 015 1-Stage Specifications

Frame Size	015							
Ratio	Unit	Note	20	25	30	40	50	60
Nominal Output Torque	[Nm]	--	48	---	46	42	41	38
Maximum Acceleration Torque	[Nm]	--	59	---	57	52	51	48
Emergency Stop Torque	[Nm]	--	209	---	192	148	150	128
No Load Running Torque	[Nm]	*1	0.51					
Nominal Input Speed	[rpm]	--	2,000					
Maximum Continuous Input Speed	[rpm]	--	4,000					
Maximum Cyclic Input Speed	[rpm]	--	4,000					
Maximum Radial Load	[N]	*2	3,110					
Maximum Axial Load	[N]	*3	1,780					
Moment of Inertia (≤ Ø14)	[kgcm <sup>2</sup> ]	--	0.54	---	0.54	0.53	0.53	0.53
Moment of Inertia (≤ Ø19)	[kgcm <sup>2</sup> ]	--	0.74	---	0.74	0.73	0.73	0.73
Moment of Inertia (≤ Ø28)	[kgcm <sup>2</sup> ]	--	1.92	---	1.92	1.91	1.91	1.91
Efficiency	[%]	*4	81	---	76	72	69	66
Torsional Rigidity	[Nm/arcmin]	--	10.3					
Maximum Torsional Backlash (Standard)	[Arc-min]	--	≤ 32					
Maximum Torsional Backlash (Low)	[Arc-min]	--	≤ 15					
Noise Level	dB [A]	*5	≤ 73					
Ambient Temperature	[°C]	--	-25 ~ 100					
Permitted Housing Temperature	[°C]	--	100					
Protection Class	--	--	IP65					
Lubrication	--	--	Synthetic Oil					
Service Life	[Hours]	--	25,000					
Weight	[kg]	*6	7					

\*1) Torque at no load applied to the input shaft at 2,000 rpm

\*2) The maximum radial load the gearbox can accept

\*3) The maximum axial load the gearbox can accept

\*4) The efficiency at the nominal output torque rating

\*5) Measured with no load applied to the input shaft at 2,000 rpm

\*6) Weight may vary slightly between models

# EJH SERIES Right-angle Worm

## EJH Dimensions – Hollow Output Shaft

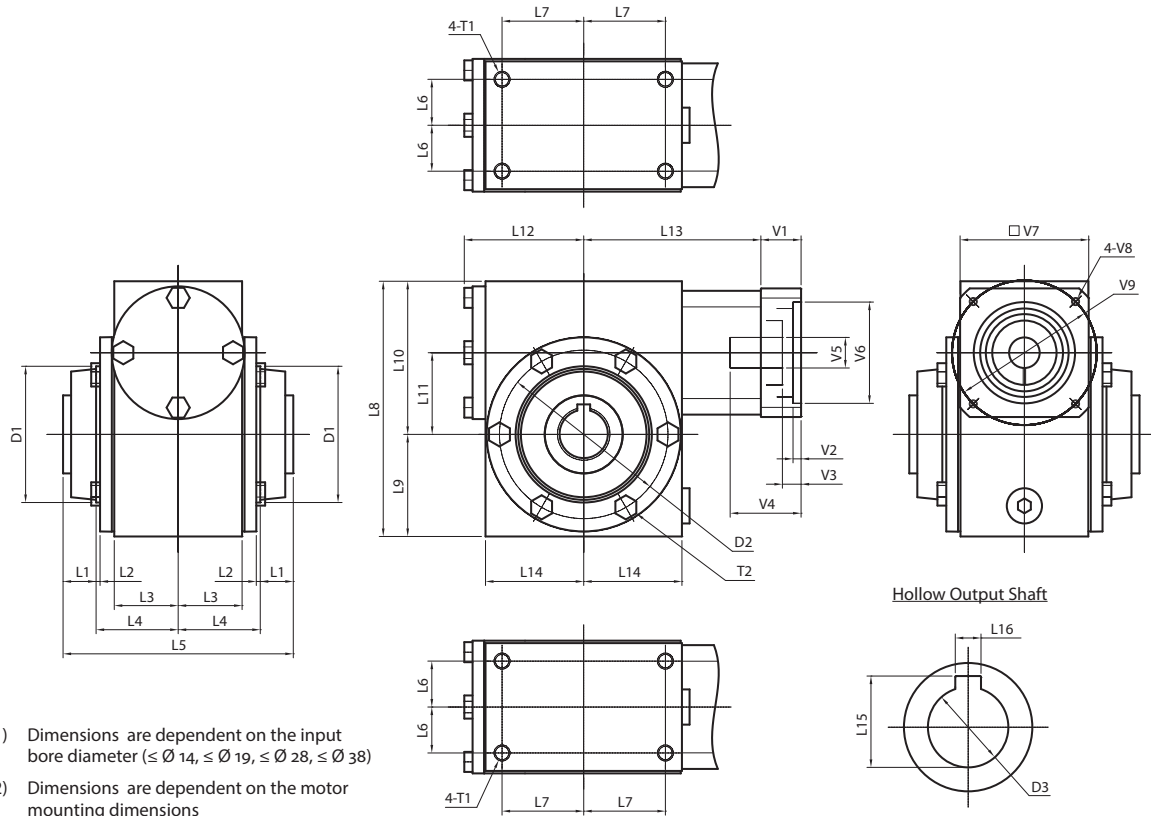

- \*1) Dimensions are dependent on the input bore diameter ( $\leq \varnothing 14$ ,  $\leq \varnothing 19$ ,  $\leq \varnothing 28$ ,  $\leq \varnothing 38$ )
- \*2) Dimensions are dependent on the motor mounting dimensions

Frame Size	Unit	Note	EJH-015	EJH-020	EJH-025	EJH-030	EJH-035
L1	[mm]	--	6.5	15.5	13.5	21.5	15
L2	[mm]	--	3.5	2.5	3	3.5	5
L3	[mm]	--	42	40	49	65	87
L4	[mm]	--	52.5	51	60.5	78.5	102
L5	[mm]	--	118	134	148	200	234
L6	[mm]	--	33.5	28.5	38	49	71.5
L7	[mm]	--	36.5	51	65	81	97
L8	[mm]	--	121	159	191	230	262
L9	[mm]	--	41.5	63.5	76	92	108
L10	[mm]	--	79.5	95.5	115	138	154
L11	[mm]	--	38.1	50.8	63.5	76.2	88.9
L12	[mm]	--	55	73	93	115	131
L13	[mm]	*1	95.5 - 105.5	113.5 - 123.5	137.5 - 149.5	156 - 168	174.5 - 186.5
L14	[mm]	--	45	61	79	98	113
L15	[mm]	--	28.5	33.5	38.5	49	64.5
L16	[mm]	--	8	8	10	14	18
D1 ±0.03	[mm]	--	ø63.45	ø84.73	ø107.11	ø135.69	ø134.26
D2	[mm]	--	ø79.5	ø105	ø125.5	ø155.5	ø184
D3 (H7)	[mm]	--	ø25	ø30	ø35	ø45	ø60
T1	[mm]	--	4xM8x12	4xM10x15	4xM10x15	4xM12x18	4xM12x18
T2	[mm]	--	4xM6 Bolts	4xM8 Bolts	8xM8 Bolts	6xM10 Bolts	6xM10 Bolts
V1 ~ V9	[mm]	*2	Motor attachment dimensions are made to fit your servo motor.				

## EJH Dimensions – Solid Output Shaft

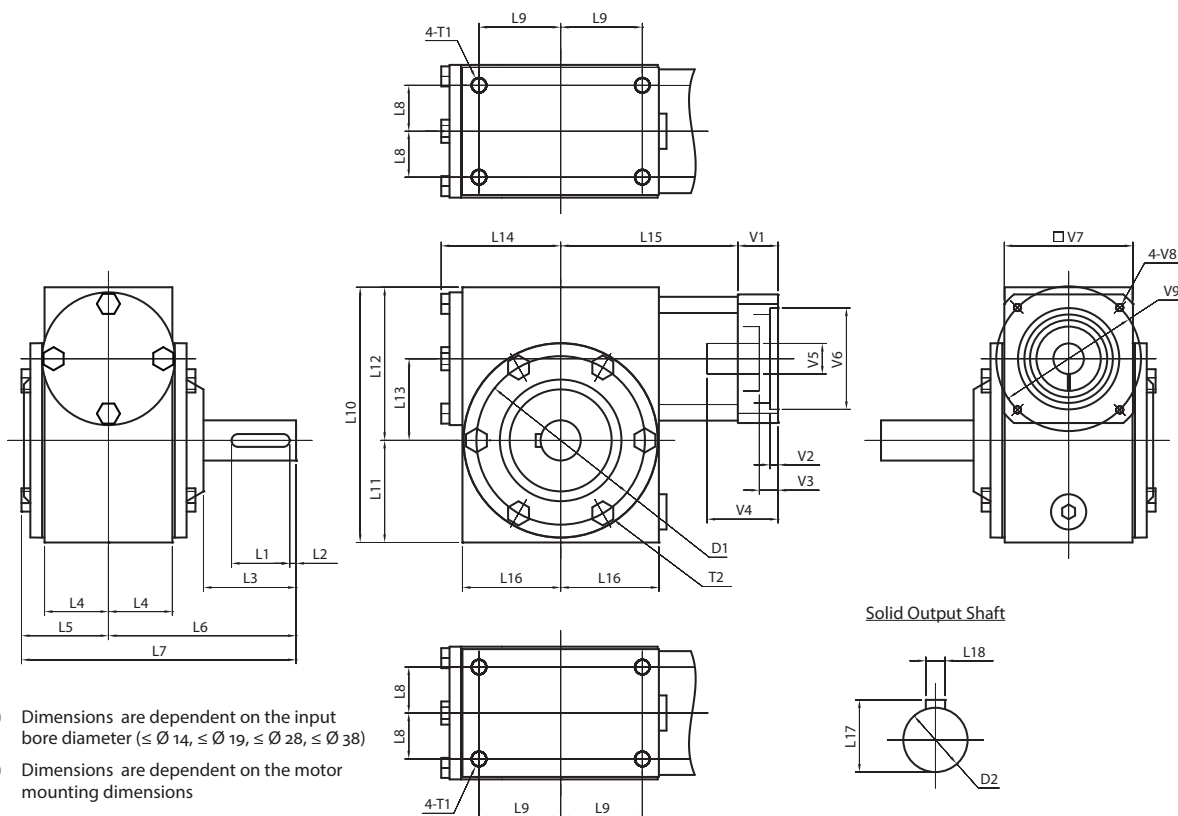

\*1) Dimensions are dependent on the input bore diameter ( $\leq \varnothing 14$ ,  $\leq \varnothing 19$ ,  $\leq \varnothing 28$ ,  $\leq \varnothing 38$ )

\*2) Dimensions are dependent on the motor mounting dimensions

Frame Size	Unit	Note	EJH-015	EJH-020	EJH-025	EJH-030	EJH-035
L1	[mm]	--	22	36	40	50	63
L2	[mm]	--	4	4	3	3	5
L3	[mm]	--	32.5	57.5	55	85.5	97.5
L4	[mm]	--	42	40	49	65	87
L5	[mm]	--	53	54.5	65.5	84	106.5
L6	[mm]	--	89	117.5	121.5	168.5	209.5
L7	[mm]	--	142	172	187	252.5	316
L8	[mm]	--	33.5	28.5	38	49	71.5
L9	[mm]	--	36.5	51	65	81	97
L10	[mm]	--	121	159	191	230	262
L11	[mm]	--	41.5	63.5	76	92	108
L12	[mm]	--	79.5	95.5	115	138	154
L13	[mm]	--	38.1	50.8	63.5	76.2	88.9
L14	[mm]	--	55	73	93	115	131
L15	[mm]	*1	95.5 - 105.5	113.5 - 123.5	137.5 - 149.5	156 - 168	174.5 - 186.5
L16	[mm]	--	45	61	79	98	113
L17	[mm]	--	22.5	28	33	41	48.5
L18	[mm]	--	6	8	8	10	14
D1	[mm]	--	$\varnothing 79.5$	$\varnothing 105$	$\varnothing 125.5$	$\varnothing 155.5$	$\varnothing 184$
D2 (k6)	[mm]	--	$\varnothing 20$	$\varnothing 25$	$\varnothing 30$	$\varnothing 38$	$\varnothing 45$
T1	[mm]	--	4xM8x12	4xM10x15	4xM10x15	4xM12x18	4xM12x18
T2	[mm]	--	4xM6 Bolts	4xM8 Bolts	8xM8 Bolts	6xM10 Bolts	6xM10 Bolts
V1 ~ V9	[mm]	*2	Motor attachment dimensions are made to fit your servo motor.				

# EJH SERIES Right-angle Worm

## EJH Dimensions – Hollow Output with Shrink Disk

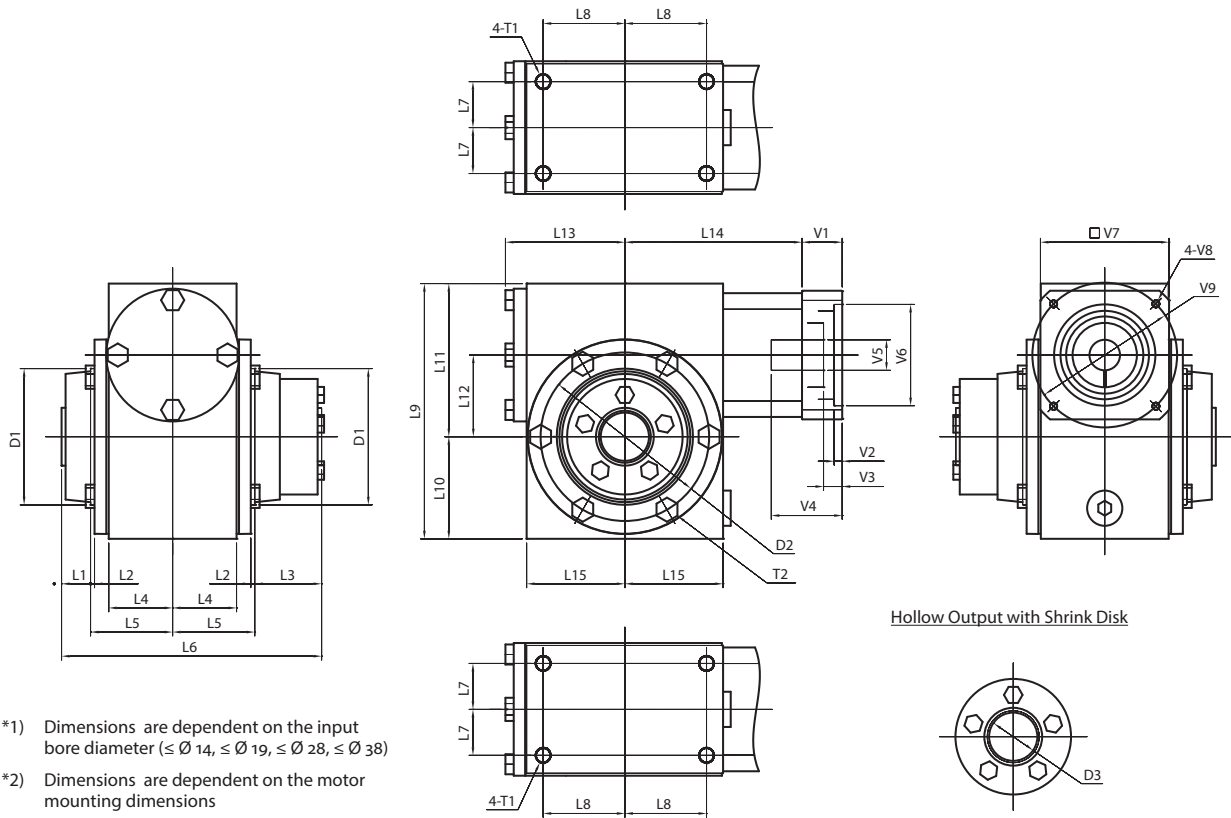

- \*1) Dimensions are dependent on the input bore diameter ( $\leq \varnothing 14$ ,  $\leq \varnothing 19$ ,  $\leq \varnothing 28$ ,  $\leq \varnothing 38$ )
- \*2) Dimensions are dependent on the motor mounting dimensions

Hollow Output with Shrink Disk

Frame Size	Unit	Note	EJH-015	EJH-020	EJH-025	EJH-030	EJH-035
L1	[mm]	--	6.5	15.5	13.5	21.5	15
L2	[mm]	--	3.5	2.5	3	3.5	5
L3	[mm]	--	30.5	41.5	48.5	56.5	57
L4	[mm]	--	42	40	49	65	87
L5	[mm]	--	52.5	51	60.5	78.5	101
L6	[mm]	--	141.5	159.5	183	235	271
L7	[mm]	--	33.5	28.5	38	49	71.5
L8	[mm]	--	36.5	51	65	81	97
L9	[mm]	--	121	159	191	230	262
L10	[mm]	--	41.5	63.5	76	92	108
L11	[mm]	--	79.5	95.5	115	138	154
L12	[mm]	--	38.1	50.8	63.5	76.2	88.9
L13	[mm]	--	55	73	93	115	131
L14	[mm]	*1	95.5 - 105.5	113.5 - 123.5	137.5 - 149.5	156 - 168	174.5 - 186.5
L15	[mm]	--	45	61	79	98	113
D1 ±0.03	[mm]	--	ø63.45	ø84.73	ø107.11	ø135.69	ø134.26
D2	[mm]	--	ø79.5	ø105	ø125.5	ø155.5	ø184
D3 (H7)	[mm]	--	ø25	ø30	ø35	ø45	ø60
T1	[mm]	--	4xM8x12	4xM10x15	4xM10x15	4xM12x18	4xM12x18
T2	[mm]	--	4xM6 Bolts	4xM8 Bolts	8xM8 Bolts	6xM10 Bolts	6xM10 Bolts
V1 ~ V9	[mm]	*2	Motor attachment dimensions are made to fit your servo motor.				

## EJH Dimensions – Optional Mounting Flange (\*1)

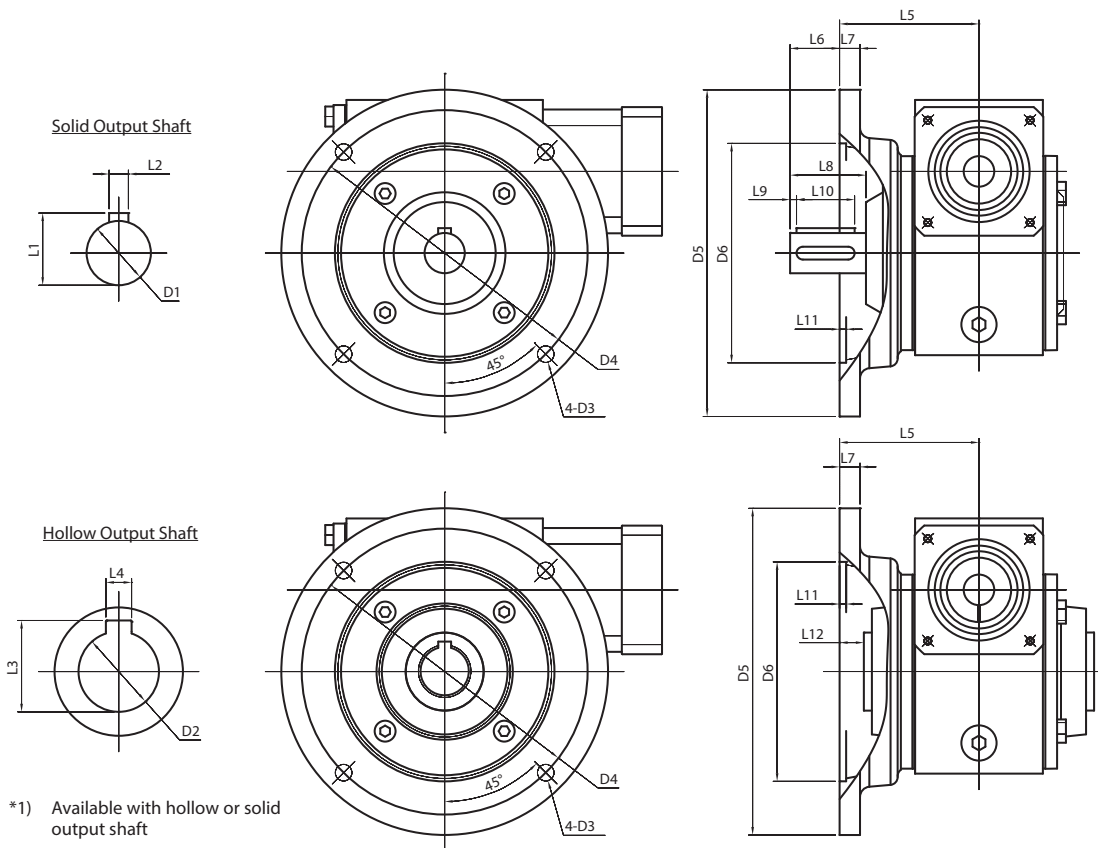

Frame Size	Unit	Note	EJH-015	EJH-020	EJH-025	EJH-030	EJH-035
L1	[mm]	--	22.5	28	33	41	48.5
L2	[mm]	--	6	8	8	10	14
L3	[mm]	--	28.5	33.5	38.5	49	64.5
L4	[mm]	--	8	8	10	14	18
L5	[mm]	--	86	87	89	111	129
L6	[mm]	--	2.5	31	32	58	80.5
L7	[mm]	--	10	13	13	13	13
L8	[mm]	--	32.5	57.5	55.0	85.5	97.5
L9	[mm]	--	4	4	3	3	5
L10	[mm]	--	22	36	40	50	63
L11	[mm]	--	4	4	5	7	7
L12	[mm]	--	27.5	20	15.5	10.5	12
D1 (k6)	[mm]	--	ø20	ø25	ø30	ø38	ø45
D2 (H7)	[mm]	--	ø25	ø30	ø35	ø45	ø60
D3	[mm]	--	ø10	ø10	ø12	ø14	ø14
D4	[mm]	--	ø149	ø178	ø210	ø241	ø267
D5	[mm]	--	ø168	ø203	ø235	ø267	ø298
D6 ±0.03	[mm]	--	ø114.30	ø136.55	ø168.30	ø196.88	ø222.28